



Book 18

**Ontario
Traffic**

December 2013

Cycling Facilities

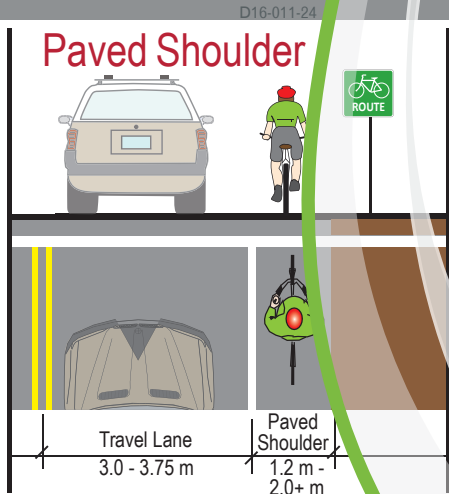

Cette publication hautement spécialisée {Ontario Traffic Manual - Book 18 – Cycling Facilities} n'est disponible qu'en anglais conformément au Règlement 671/92, selon lequel il n'est pas obligatoire de la traduire en vertu de la Loi sur les services en français. Pour obtenir des renseignements en français, veuillez communiquer avec le ministère des Transports de l'Ontario par courriel à otm@ontario.ca.

ISBN 978-1-4606-3570-4
Copyright © 2014
Queen's Printer for Ontario
All rights reserved.

Ontario Traffic Manual

Foreword

The purpose of the Ontario Traffic Manual (OTM) is to provide information and guidance for transportation practitioners, and to promote uniformity of treatment in the design, application and operation of traffic control devices and systems across Ontario. The objective is safe driving behaviour, achieved by a predictable roadway environment through the consistent, appropriate application of traffic control devices. Additional purposes of the OTM are to provide a set of guidelines consistent with the intent of the Highway Traffic Act, and to provide a basis for road authorities to generate or update their own guidelines and standards.

The OTM is made up of a number of Books which are being generated over a period of time, and for which a process of continuous updating is planned. Through the updating process, it is proposed that the OTM will become more comprehensive and representative by including many traffic control devices and applications specific to municipal use. Some of the Books of the OTM are new, while others incorporate updated material from the Ontario Manual of Uniform Traffic Control Devices (MUTCD) and the King's Highway Guide Signing Policy Manual (KHGSPM).

The OTM is directed to its primary users, traffic practitioners. It incorporates current best practices in the Province of Ontario. The interpretations, recommendations and guidelines in the OTM are intended to provide an understanding of traffic

operations over a broad range of traffic situations encountered in practice. They are based on many factors which may determine the specific design and operational effectiveness of traffic control systems. However, no manual can cover all contingencies or all cases encountered in the field. Therefore, field experience and knowledge of application are essential in deciding what to do in the absence of specific direction from the Manual itself, and in overriding any recommendations in this Manual.

The traffic practitioner's fundamental responsibility is to exercise good engineering judgement and experience on technical matters in the best interests of the public and workers. Guidelines are provided in the OTM to assist in making those judgments, but they should not be used as a substitute for good judgment.

Design, application, operational guidelines and procedures should be used with judicious care and proper consideration of the prevailing circumstances. In some designs, applications or operational features, the traffic practitioner's judgement is to meet or exceed a guideline while in others a guideline might not be met for sound reasons, such as space availability, yet still produce a design or operation which may be judged to be safe. Every effort should be made to stay as close to the guidelines as possible in situations like these, and to document reasons for departures from them.

Custodial Office

Inquiries, suggestions or comments regarding the Ontario Traffic Manual May be directed to:

Ministry of Transportation of Ontario (MTO)
Traffic Office
301 St. Paul Street, 2nd Floor South
St. Catharines, Ontario
L2R 7R4
Phone: 905-704-2960
Fax: 905-704-2888
e-mail: otm@ontario.ca

Book 18 Acknowledgements

The Ontario Traffic Manual Book 18 (Cycling Facilities) was made possible as a result of the generous funding support from the Ministry of Transportation of Ontario and a number of Ontario Municipalities. The Ontario Traffic Council would like to thank the following individuals and their organizations for their contribution in the development of OTM Book 18:

Consultant Team:

Marco D'Angelo – Ontario Traffic Council
Dave Richardson, P.Eng., PTOE – MMM Group
Dave McLaughlin, MCIP, RPP – MMM Group

Technical Advisors:

Jim Dowell, P.Eng. – MMM Group
Bob Koziol, P.Eng. – MMM Group
Marc Jolicoeur, P.E. – Vélo Québec
Jeff Olson, R.A. – Alta Planning + Design

Technical Support:

Claire Basinski, MCIP, RPP – MMM Group
Dorothy Kowpak, MCIP, RPP – MMM Group
Jonathan Mang, CET – MMM Group
Michael Parker – MMM Group
Kevin Yeung – MMM Group
Sarah Krapez – MMM Group
Phil Goff – Alta Planning + Design

Independent Reviewer:

Gerry Forbes, P.Eng., PTOE – INTUS Road Safety Engineering Inc.

Technical Committee and Funding Supporters:

Nelson Cadete – City of Brampton
Kara Van Myall – Bruce County
Jack Van Dorp – Bruce County
Pat David – Bruce County
Dan Ozimkovic – City of Burlington
Vito Tolone – City of Burlington
Daryl Bender – City of Hamilton
Hart Solomon – City of Hamilton
Heide Schlegl – Town of Milton
Jacquelyn Hayward Gulati – City of Mississauga
Jacqueline Hunter – City of Mississauga
Phil Bergen – Region of Niagara
Petar Vujic – Region of Niagara
Chris Clapham – Town of Oakville
Robert Grimwood – City of Ottawa
Zlatko Krstulic – City of Ottawa
Dave Shelsted – City of Greater Sudbury
Lukasz Pawlowski – City of Toronto
Selma Hubjer – City of Vaughan
Geoffrey Haines – City of Vaughan
Garrett Donaher – Region of Waterloo
John Hill – Region of Waterloo
Yvonne Kaczor – York Region
Jason Mainprize – York Region
Vi Bui – York Region
Roger De Gannes – Ministry of Transportation
Terry Short – Ministry of Transportation

The Ontario Traffic Council would also like to thank the Transportation Association of Canada (TAC), a national not-for-profit association that promotes the provision of safe, secure, efficient, effective and environmentally and financially sustainable transportation services in support of Canada's social and economic goals. All figures that have been excerpted from the TAC publication: *Bikeway Traffic Control Guidelines for Canada – Second Edition (2012)* are reproduced with the express written authority of the Transportation Association of Canada (TAC).

Table of Contents

1.	GENERAL INFORMATION	1
1.1	Introduction	1
1.2	Sections of this Book	2
1.3	Bicycle Features & Rules of the Road	3
1.4	The Design Domain Concept	7
1.5	Cycling Myths.....	7
2.	BIKEWAY NETWORK PLANNING	11
2.1	User Characteristics	11
2.1.1	Age	11
2.1.2	Skill and Comfort Level	12
2.1.3	Trip Purpose	14
2.1.4	Other Potential Users	14
2.2	Bicycle Operating Requirements	14
2.3	Types of Bicycle Facilities	15
2.3.1	On-Road Facilities	16
	2.3.1.1 Shared Roadway and Signed Bicycle Route	16
	2.3.1.2 Signed Bicycle Route with Paved Shoulder	16
	2.3.1.3 Conventional Bicycle Lane	17
	2.3.1.4 Separated Bicycle Lane	18
	2.3.1.5 Contraflow Bicycle Lane	18
	2.3.1.6 Raised Cycle Track	18
	2.3.1.7 Bicycle Priority Street	19
2.3.2	In-Boulevard Bicycle Facilities	19
	2.3.2.1 Active Transportation Path	19
2.4	Route Selection Criteria	20
2.4.1	Access and Potential Use	20
2.4.2	Connectivity and Directness	20
2.4.3	Physical Barriers	21
2.4.4	Attractiveness.....	21
2.4.5	Safety and Comfort	21
2.4.6	Cost	22

2.4.7	Accommodation of Existing and Future Demand	22
2.4.8	Consistent with Local Tourism Strategies and Goals	22
2.5	Bicycle Design Supporting Complete Streets	22
2.6	Support Features	22
2.6.1	Bicycle Parking Facilities	22
2.6.2	Other End-of-Trip Facilities.....	23
2.6.3	Rest Areas.....	23
2.6.4	Emergency and Service Vehicle Access.....	23
2.7	Information Regarding Maintenance	23
3.	BICYCLE FACILITY SELECTION TOOL	25
3.1	General	25
3.2	Overview of the Bicycle Facility Type Selection Process	26
3.2.1	Suitable Application Environments	26
3.2.2	The Process	26
	<i>3.2.2.1 Step 1: Facility Pre-Selection</i>	<i>28</i>
	<i>3.2.2.2 Step 2: A More Detailed Look</i>	<i>31</i>
	<i>3.2.2.3 Step 3: Justify Your Rationale</i>	<i>39</i>
4.	BICYCLE FACILITY DESIGN	41
4.1	Shared Roadways	42
4.1.1	Shared Roadways and Signed Bicycle Routes	42
	<i>4.1.1.1 Geometry</i>	<i>42</i>
	<i>4.1.1.2 Signs</i>	<i>44</i>
	<i>4.1.1.3 Pavement Markings</i>	<i>47</i>
	<i>4.1.1.4 Design Applications</i>	<i>48</i>
4.1.2	Signed Bicycle Route with Paved Shoulders	51
	<i>4.1.2.1 Geometry</i>	<i>51</i>
	<i>4.1.2.2 Signs</i>	<i>54</i>
	<i>4.1.2.3 Pavement Markings</i>	<i>54</i>
	<i>4.1.2.4 Design Applications</i>	<i>55</i>
4.2	Bicycle Lanes	60
4.2.1	Conventional Bicycle Lanes	60
	<i>4.2.1.1 Geometry</i>	<i>60</i>
	<i>4.2.1.2 Signs</i>	<i>63</i>
	<i>4.2.1.3 Pavement Markings</i>	<i>64</i>
	<i>4.2.1.4 Design Applications</i>	<i>66</i>

4.2.2	Separated Bicycle Lanes	86
4.2.2.1	<i>Geometry</i>	86
4.2.2.2	<i>Signs</i>	89
4.2.2.3	<i>Pavement Markings</i>	91
4.2.2.4	<i>Design Applications</i>	93
4.2.3	Contraflow Bicycle Lanes	98
4.2.3.1	<i>Geometry</i>	98
4.2.3.2	<i>Signs</i>	99
4.2.3.3	<i>Pavement Markings</i>	101
4.2.3.4	<i>Design Applications</i>	103
4.3	Raised Cycle Tracks	105
4.3.1	One-way and Two-way Raised Cycle Tracks	105
4.3.1.1	<i>Geometry</i>	105
4.3.1.2	<i>Signs</i>	108
4.3.1.3	<i>Pavement Markings</i>	110
4.3.1.4	<i>Design Applications</i>	111
4.4	In-Boulevard Facilities	115
4.4.1	In-Boulevard Bicycle Facilities and In-Boulevard Active Transportation Facilities	115
4.4.1.1	<i>Geometry</i>	115
4.4.1.2	<i>Signs</i>	117
4.4.1.3	<i>Pavement Markings</i>	119
4.4.1.4	<i>Design Applications</i>	121
5.	ADDITIONAL BICYCLE FACILITY DESIGN APPLICATIONS	129
5.1	Bicycle Priority Streets	129
5.1.1	Design Applications	132
5.2	Integrating Bicycle Facilities through Road Retrofits	134
5.2.1	Retrofitting by Widening the Roadway (Reconstruction)	134
5.2.2	Retrofitting Without Roadway Widening (Reallocation of Road Space)	134
5.2.3	Road Diet	136
5.2.4	In-Boulevard Facilities	136
5.3	Integrating Bicycle Facilities at Roundabouts	137
5.3.1	Single Lane Roundabout	137
5.3.2	Multi-Lane Roundabouts	138
5.4	Conflict Zones	139
5.4.1	Motorist – Cyclist Conflicts	139

	5.4.1.1 <i>On-Road Conflicts</i>	139
	5.4.1.2 <i>Crossing Point Conflicts</i>	142
	5.4.2 Transit Stops	144
5.5	Integrating Bicycle Facilities at Interchanges and Ramp Crossings	146
	5.5.1 Bicycle Lane Across Lower Speed Diverging Ramp Facility	146
	5.5.2 Bicycle Lane Across Lower Speed Diverging Ramp Facility with Parallel Lane	147
	5.5.3 Bicycle Lane Across Lower Speed Merging Ramp Facility	148
	5.5.4 Bicycle Lane Across Lower Speed Merging Ramp Facility with Acceleration Lane	149
	5.5.5 Bicycle Crossing at a High-Speed Diverging Ramp	150
	5.5.6 Bicycle Lane Jug Handle at Diverging Ramp Facility	151
	5.5.7 Bicycle Crossing at a High-Speed Merging Ramp	152
5.6	Integrating Bicycle Facilities at Grade Separations	153
5.7	Integrating Bicycle Facilities at Railway Crossings	156
5.8	Bicycle Signals	159
	5.8.1 Crossrides	159
	5.8.1.1 <i>Separate Crossride</i>	159
	5.8.1.2 <i>Combined Crossride</i>	159
	5.8.1.3 <i>Mixed Crossride</i>	160
	5.8.1.4 <i>MidBlock Crossride</i>	160
	5.8.2 Intersection Signals.....	162
5.9	Other Design Considerations	164
	5.9.1 Drainage Grates and Utility Covers	164
	5.9.2 Fences, Railings and Barriers	165
	5.9.3 Lighting	166
5.10	Temporary Conditions	167
6.	IMPLEMENTING A BIKEWAY NETWORK	169
	6.1 Five-Stage Implementation Process	169
	6.1.1 Phase 1: Preliminary Review	171
	6.1.2 Phase 2: Bicycle Facility Type Selection	171
	6.1.3 Phase 3: Facility Design	172
	6.1.4 Phase 4: Monitoring Phase	172
	6.1.5 Update to the Municipality's Official Plan	172
7.	SUPPORT FEATURES.....	173
	7.1 Bicycle Parking Facilities.....	173

7.1.1	Type and Location of Bicycle Parking Area	173
7.1.2	Visibility and Security.....	174
7.1.3	Type of Bicycle Parking Facility.....	175
7.1.4	Clearance Considerations	177
7.2	Other End-of-Trip Facilities	180
7.2.1	Bike Rooms	180
7.2.2	Showers and Change Rooms	181
7.3	Rest Areas	181
7.4	Emergency and Service Vehicle Access	182
8	MAINTENANCE STRATEGIES FOR BICYCLE FACILITIES	183
8.1	Sweeping	184
8.2	Surface Repairs	184
C.2.1	Bumps and Depressions	185
C.2.2	Cracking	185
C.2.3	Potholes	186
C.2.4	Pavement Drop-off At Shoulders	187
8.3	Vegetation Management	188
8.4	Maintenance of Signage and Pavement Markings	188
8.5	Drainage Improvements	189
8.6	Winter Maintenance	189
8.7	Parking Facilities	191

Appendices

A.	GLOSSARY.....	193
-----------	----------------------	------------

List of Figures

Figure 2.1	Four Types of Cyclist	13
Figure 2.2	Cyclist Operating Space	15
Figure 2.3	Shared Roadway with Sharrows	16
Figure 2.4	Paved Shoulder	17
Figure 2.5	Conventional Bicycle Lane	17
Figure 2.6	Separated Bicycle Lane	18
Figure 2.7	Raised Cycle Track	19
Figure 2.8	Bicycle Priority Street	19
Figure 2.9	An Example of a Shared Use AT Path.....	20
Figure 3.1	Bicycle Facility Type Selection 3-Step Process Flow Chart	26
Figure 3.2	Model Worksheet for the Facility Type Selection Tool	27
Figure 3.3	Desirable Bicycle Facility Pre-Selection Nomograph	30
Figure 4.1	Examples of Shared Roadways and Signed Bicycle Routes	44
Figure 4.2	Cross-Sections of Shared Roadways and Signed Bicycle Routes	45
Figure 4.3	Bicycle Route Marker Sign	45
Figure 4.4	Share the Road and Shared Use Lane Single File Signs	46
Figure 4.5	Motor Vehicle Passing Prohibited Signs	46
Figure 4.6	'Sharrows' Pavement Marking	47
Figure 4.7	Wide Signed Bicycle Route without On-Street Parking	48
Figure 4.8	Wide Signed Bicycle Route with On-Street Parking	49
Figure 4.9	Narrow Signed Bicycle Route without On-Street Parking	49
Figure 4.10	Narrow Signed Bicycle Route with On-Street Parking	50
Figure 4.11	Examples of Signed Bicycle Routes with Paved Shoulders	52
Figure 4.12	Cross-Sections of Signed Bicycle Routes with Paved Shoulder	53
Figure 4.13	Bicycle Route Marker Sign	54
Figure 4.14	Solid White Edge Line	54
Figure 4.15	Signed Bicycle Route with Paved Shoulders and Marked Buffer	55
Figure 4.16	Signed Bicycle Route with Paved Shoulders and Rumble Strips	55
Figure 4.17a	Shoulder Rumble Strips for 0.5m Bicycle Buffer Zone	57
Figure 4.17b	Shoulder Rumble Strips for 1.0m Bicycle Buffer Zone	58
Figure 4.17c	Shoulder Rumble Strips for 1.5m Bicycle Buffer Zone	59
Figure 4.18	Examples of Conventional Bicycle Lanes	62
Figure 4.19	Cross-Sections of Conventional Bicycle Lanes	62
Figure 4.20a	Overhead and Ground-mounted Reserved Bicycle Lane Signs (OTM)	63
Figure 4.20b	Reserved Lane Begins and Ends Tab Signs (OTM)	63
Figure 4.21	Reserved Bicycle Lane Signs (TAC)	63
Figure 4.22	Reserved Bicycle Lane Ahead Sign	64
Figure 4.23	Turning Vehicles Yield to Bicycles Sign	64
Figure 4.24	Solid White Bicycle Lane Line	65
Figure 4.25	Dashed White Bicycle Lane Line	65
Figure 4.26	Bicycle Lane Pavement Markings	65
Figure 4.27	Bicycle Lane on Two-Lane Two-Way Road with On-Street Parking	66

Figure 4.28	Introduced and Discontinued Bicycle Lanes at an Intersection	67
Figure 4.29	Introduced Midblock Bicycle Lane where Roadway Widens	68
Figure 4.30	Discontinued Midblock Bicycle Lane where Roadway Narrows	68
Figure 4.31	Midblock Bicycle Lane (Transition to Through Lane with Shared Facility)	69
Figure 4.32	Tapers for Introduced and Discontinued Bicycle Lanes with No Change in Pavement Width	69
Figure 4.33	Bicycle Lane Transition to Shared Through Lane on Road with On-Street Parking	70
Figure 4.34	Bicycle Lane Transition to Shared Right-Turn (Except Bicycles) Lane on Road with On-Street Parking	70
Figure 4.35	Bicycle Lane Transition to Shared Right-Turn (Except Bicycles) Lane on Road without On-Street Parking	71
Figure 4.36	Bicycle Lane Adjacent to Curb Lane Transition	71
Figure 4.37	Bicycle Lane Adjacent to Introduced Right-Turn Lane	72
Figure 4.38	Bicycle Lane Adjacent to Parking and Introduced Right-Turn Lane	73
Figure 4.39	Bicycle Lane Adjacent to Combined Through / Right-Turn Lane (Dashed Line)	74
Figure 4.40	Bicycle Lane Adjacent to Combined Through / Right-Turn Lane (Solid Line)	75
Figure 4.41	Bicycle Lane Adjacent to Combined Through / Right-Turn Lane (Solid Line with Optional Stop Bars)	76
Figure 4.42	Guide Lines for Through Moving Cyclists	77
Figure 4.43	Optional Sharrow Application in an Intersection	78
Figure 4.44	Bicycle Lane Adjacent to Merge Lane with Island	79
Figure 4.45	Bicycle Lane Adjacent to Far Side Bus Bay	79
Figure 4.46	Bicycle Lane Adjacent to Right-Turn Lane and Downstream Merge Lane	80
Figure 4.47	Bicycle Lane Adjacent to Shared Through / Right-Turn Lane and Downstream Merge Lane	80
Figure 4.48	Exclusive Left-Turn Bicycle Lane Slot	81
Figure 4.49	Left-Turn Bicycle Lane Guide Lines Through Intersection	82
Figure 4.50	Bike Box Design	83
Figure 4.51	Two-Stage Left Turn Queue Box Aligned with Parking Lane Adjacent to Bicycle Lane	85
Figure 4.52	An Example of a Jug Handle at an Urban T-intersection	85
Figure 4.53	Examples of Separated Bicycle Lanes	88
Figure 4.54	Cross-Sections of Separated Bicycle Lanes with Buffers	89
Figure 4.55a	Overhead and Ground-mounted Reserved Bicycle Lane Signs (OTM)	90
Figure 4.55b	Reserved Lane Begins and Ends Tab Signs (OTM)	90
Figure 4.56	Reserved Bicycle Lane Signs (TAC)	90
Figure 4.57	Reserved Bicycle Lane Ahead Sign	91
Figure 4.58	Turning Vehicles Yield to Bicycles Sign	91
Figure 4.59	Bicycle Lane Pavement Markings	92
Figure 4.60	Solid White Bicycle Lane Line	92
Figure 4.61	An Example of a Separated Bicycle Lane, Toronto	92
Figure 4.62	Dashed White Bicycle Lane Line	93
Figure 4.63	Separated Bicycle Lane with Barrier on Approach to Staggered Stop Bar	94
Figure 4.64	Two-Stage Left Turn Queue Box in Curb Area	96

Figure 4.65	Two-Stage Left Turn Queue Box with Parking Lane Adjacent to Bicycle Lane	96
Figure 4.66	An Example of a Context Specific Two-Stage Queue Box within the Boulevard	97
Figure 4.67	Examples of Contraflow Bicycle Lanes	99
Figure 4.68	'Bicycles Excepted' Tab Sign	99
Figure 4.69a	Overhead and Ground-mounted Reserved Bicycle Lane Signs (OTM)	100
Figure 4.69b	Reserved Lane Begins and Ends Tab Signs (OTM)	100
Figure 4.70	Reserved Bicycle Lane Signs (TAC)	100
Figure 4.71	Contraflow Bicycle Lane Crossing Sign	101
Figure 4.72	Yellow Contraflow Lane Line	101
Figure 4.73	Bicycle Lane Pavement Markings	102
Figure 4.74	Contraflow Bicycle Lane (on-street parking on one side of the road)	103
Figure 4.75	Contraflow Bicycle Lane (on-street parking on both sides of the road)	104
Figure 4.76	Examples of One-way and Two-Way Cycle Tracks	107
Figure 4.77	Cross-Sections of One-Way and Two-Way Cycle Tracks	107
Figure 4.78a	Overhead and Ground-mounted Reserved Bicycle Lane Signs (OTM)	108
Figure 4.78b	Reserved Lane Begins and Ends Tab Signs (OTM)	108
Figure 4.79	Reserved Bicycle Lane Signs (TAC)	108
Figure 4.80	Bicycle Trail Crossing Side Street Sign	109
Figure 4.81	Trail Crossing Tab Sign	109
Figure 4.82	Turning Vehicles Yield to Bicycles Sign	110
Figure 4.83	Bicycle Lane Pavement Markings	110
Figure 4.84	Solid White Bicycle Lane Line	111
Figure 4.85	Cycle Track Raised at Bus Stop	111
Figure 4.86	Raised Cycle Track Transition to a Conventional Bike Lane on the approach to an Intersection	113
Figure 4.87	Raised Cycle Track Carried Through an Intersection	114
Figure 4.88	Examples of In-Boulevard Facilities	116
Figure 4.89	Cross-Sections of In-Boulevard Facilities	116
Figure 4.90	Shared Pathway Sign	117
Figure 4.91	Pathway Organization Sign	117
Figure 4.92	Yield to Pedestrians Sign	118
Figure 4.93	Dismount and Walk Sign	118
Figure 4.94	Pedestrian and Bicycle Crossing Ahead Sign	118
Figure 4.95	Pedestrian and Bicycle Crossing Tab Sign	119
Figure 4.96	Bicycle Trail Crossing Side Street Sign	119
Figure 4.97	Trail Crossing Tab Sign	119
Figure 4.98	Typical Pavement Markings for Two-way In-Boulevard Shared Use Paths (Broken versus solid yellow centre line)	120
Figure 4.99	Bicycle Pavement Markings	120
Figure 4.100	Typical Elephant's Feet Pavement Markings for Crossrides	120
Figure 4.101	Separate Pedestrian and Cyclist Crossride (Signalized Example)	122
Figure 4.102	Combined Pedestrian and Cyclist Crossride (Signalized Example)	123
Figure 4.103	Mixed Pedestrian and Cyclist Crossride (Unsignalized Example)	124
Figure 4.104	Jug Handle Treatment at T-intersection	126

Figure 5.1	Bicycle Priority Street Design Elements	130
Figure 5.2	Design Elements on a Typical Bicycle Priority Street	131
Figure 5.3	One-Lane Chicane Roadway with Two-Way Traffic	132
Figure 5.4	Shared Use Markings on Two-Lane Chicaned Roadway	133
Figure 5.5	Bicycle Lane on Chicaned Roadway	133
Figure 5.6	Bicycle Lane Markings across a Speed Hump	134
Figure 5.7	An Example of Narrowing Vehicular Lane Widths for the Implementation of Bicycle Facilities	135
Figure 5.8	An Example of Removing and Narrowing Parking Lanes of the Implementation of Bicycle Facilities	136
Figure 5.9	Bicycle Lane at a Single Lane Roundabout, No Bicycle Bypass	137
Figure 5.10	Tapered Ramp Example	138
Figure 5.11	Bicycle Lane at a Multi-Lane Roundabout with Bicycle Bypass	139
Figure 5.12	Sharrow Markings in a Conflict Zone	140
Figure 5.13	White Dashed Markings in Conflict Zone	141
Figure 5.14	White Dashed Bicycle Markings and Bicycle Stencils in a Conflict Zone	141
Figure 5.15	Contraflow cyclist / side-street driver	143
Figure 5.16	Contraflow cyclist / main-street driver	143
Figure 5.17	With-flow cyclist / main-street driver	143
Figure 5.18	Stopped motor vehicles may block the path	143
Figure 5.19	Bicycle Lane Passing a Transit Stop	145
Figure 5.20	Cycle Facility at Transit Stop (Roncesvalles Avenue, Toronto)	145
Figure 5.21	Cycle Facility at Transit Stop (Sherbourne Street, Toronto)	145
Figure 5.22	Bicycle Lane across Lower Speed (≤ 70 km/h) Diverging Ramp Facility	146
Figure 5.23	Context Specific Example of Cyclist Crossing at Low-Speed On-Ramp with Green Surface Treatment and Pavement Markings	147
Figure 5.24	Bicycle Lane across Lower Speed (≤ 70 km/h) Diverging Ramp Facility with Parallel Lane	147
Figure 5.25	Bicycle Lane across Lower Speed (≤ 70 km/h) Merging Ramp Facility	148
Figure 5.26	Bicycle Lane across Lower Speed (≤ 70 km/h) Merging Ramp Facility with Acceleration Lane	149
Figure 5.27	Bicycle Crossing at a High-Speed Diverging Ramp	150
Figure 5.28	Bicycle Lane Jug Handle at Diverging Ramp Facility	151
Figure 5.29	Bicycle Crossing at a High-Speed Merging Ramp	152
Figure 5.30	Side Clearance at Bridges	155
Figure 5.31	Bicycle Lane at Skewed Railway Crossing – Gate Controlled	157
Figure 5.32	Bicycle Lane at Skewed Railway Crossing – Ungated Control	157
Figure 5.33	Bicycle Lane Jug Handle at Skewed Railway Crossing – Gate Controlled	158
Figure 5.34	Bicycle Lane Jug Handle at Skewed Railway Crossing – Ungated Control	158
Figure 5.35	Separate Crossside	159
Figure 5.36	Combined Crossside	160
Figure 5.37	Mixed Crossside.....	160
Figure 5.38	Midblock Crossside.....	161
Figure 5.39	Example of a Bicycle Signal Head.....	162
Figure 5.40	Standard Bicycle Signal Head	162

Figure 5.41	Bicycle Signal Loop Detector Stencil Sign	163
Figure 5.42	Bicycle Signal Loop Detector Stencil Pavement Marking	163
Figure 5.43	Signalized Intersection Crossing Sign	163
Figure 5.44	Example Pavement Marking for Bicycle Actuation Location	163
Figure 5.45	Example of Cyclist Pushbutton	163
Figure 5.46	Catch Basin Inlet within the Curb Face	165
Figure 5.47	Example of a Drainage Grate with Herring Bone Openings	165
Figure 5.48	Bicycle Lane Closed Sign	167
Figure 5.49	Bicycle Lane Detour Markers	168
Figure 5.50	Grooved Pavement Sign	168
Figure 5.51	Distance Advisory Tab Signs	168
Figure 6.1	Five-Stage Implementation Schedule	170
Figure 7.1	An Example of Short-Term Parking	173
Figure 7.2	An Example of Long-Term Parking	174
Figure 7.3	Sheltered Bicycle Parking	174
Figure 7.4	Post and Ring Stand	175
Figure 7.5	Ring Rack	175
Figure 7.6	Cora Bike Rack	175
Figure 7.7	Improper Use of Ribbon Bike Rack	175
Figure 7.8	The Bridge Rack is a Poor Example of a Bike Rack	176
Figure 7.9	12 Sided Polygon Bike Lockers	177
Figure 7.10	Bike Locker Secured with Personal Lock	177
Figure 7.11	Bike Lockers Located in a Parking Garage	177
Figure 7.12	Mesh Panels Allow for Surveillance of Lockers Contents	177
Figure 7.13	Basic Dimensions for the One Bicycle per Stand Perpendicular Configuration	179
Figure B.14	Two Partially Overlapping Rows of Perpendicular Parked Bicycles	179
Figure 7.15	Basic Dimensions for the Two Bicycles per Stand Perpendicular Configuration	180
Figure 7.16	Bike Room	180
Figure 7.17	Bike Repair Station	181
Figure 7.18	An Example of a Change Room	181
Figure 7.19	Bollards on Finch Corridor, Toronto	182
Figure 8.1	An Example of Seasonal Sweeping Requirements	184
Figure 8.2	Poorly Maintained Bicycle Lane	185
Figure 8.3	Well Maintained Bicycle Facility	185
Figure 8.4	Pothole Identified by Hazard Marker	187
Figure 8.5	Poor Drainage Causes Puddling in Bike Lane	189
Figure 8.6	Bicycle Lane is Not Cleared of Snow	190
Figure 8.7	Bicycle Facility is Cleared of Snow	190

List of Tables

Table 1.1	Bicycle Specific Rules of the Road	4
Table 3.1	85th Percentile Motor Vehicle Operating Speeds	31
Table 3.2	Motor Vehicle Volumes	32
Table 3.3	Function of Street or Road or Highway	32
Table 3.4	Vehicle Mix	33
Table 3.5	Collision History	33
Table 3.6	Available Space	34
Table 3.7	Costs	35
Table 3.8	Anticipated Users in terms of Skill and Trip Purpose	35
Table 3.9	Level of Bicycle Use	36
Table 3.10	Function of Route within the Bicycle Facility Network	36
Table 3.11	Type of Roadway Improvement Project	37
Table 3.12	On-Street Parking (for urban situations)	38
Table 3.13	Frequency of Intersections (for urban situations)	39
Table 4.1	Desired and Suggested Minimum Lane Widths for Urban Shared Roadways / Signed Bicycle Routes	43
Table 4.2	Desired and Suggested Minimum Paved Shoulders Widths for Rural Cross-Sections on Signed Bicycle Routes	52
Table 4.3	Desired and Suggested Minimum Widths for Bicycle Lanes (to the face of curb)	61
Table 4.4	Desired and Suggested Minimum Widths for Separated Bicycle Lanes	87
Table 4.5	Desired and Suggested Minimum Widths for a Contraflow Bicycle Lane (to the face of curb)	98
Table 4.6	Desired and Suggested Minimum Widths for Cycle Tracks (excluding curb to travel lane)	106
Table 4.7	Desired and Suggested Minimum Widths for In-Boulevard Bicycle Facilities	115
Table 5.1	Minimum Side Clearances at Bridges	154
Table 5.2	Cyclist Considerations for Drainage Grates and Utility Covers	164
Table 5.3	Illumination Levels for Bicycle Facilities	166

1. General Information

1.1 Introduction

The Ontario Traffic Manual (OTM) is a series of traffic engineering and traffic control reference manuals produced by the Ministry of Transportation of Ontario (MTO) for use by municipalities in Ontario. As of 2013, nine of the 22 Books have been completed, and the Ministry has established a process of updating the Books as required.

The OTM series provides guidelines on various traffic control devices. **OTM Book 18 – Cycling Facilities** has been developed by MTO in association with the Ontario Traffic Council (OTC). At the time of publication, the design guidelines presented in OTM Book 18 are considered to be consistent with the intent of the Highway Traffic Act (HTA) with respect to municipal roads and infrastructure. MTO acknowledges that as the application of Book 18 evolves over time, the HTA may require further clarification to accommodate new and evolving cycling facilities. Funding and technical support has come from the Ministry as well as a Steering Committee comprised of sponsoring municipalities.

A complete listing of the planned and previously completed OTM volumes is found in Book 1. A new edition of Book 1 will be released to coincide with the production of each new Book in the OTM series. This is necessary in order to have a master table of contents and indices which are up-to-date at any given time. Book 1 should be read prior to the application of any of the other Books in the OTM series. The use of any of the devices and applications discussed in those Books should be considered in conjunction with the contents of other related OTM Books as appropriate.

The purpose of Book 18 is to provide practical guidance on the planning, design and operation of cycling facilities in Ontario. It applies to on- and off-road facilities within the road right-of-way, however off-road trails through parks, ravines, Hydro corridors or open space are outside of its scope. It is for use by traffic engineers, planners and other transportation practitioners, and promotes a uniform approach across the province. The other objectives of the OTM are to provide a set of guidelines consistent with the intent of the Highway Traffic Act (HTA) and to establish a basis for municipalities to generate or update their own guidelines and standards.

Book 18 includes consolidated references to relevant material that is provided in other OTM Books as applicable to bicycle facility planning, design and traffic control. Book 18 incorporates current best practices in Ontario, Canada and internationally. The guidelines cover a broad range of traffic situations, and they are based on many factors which determine the specific design and operational effectiveness of bicycle facilities.

No manual can cover all situations encountered in the field. Therefore, knowledge of application and field experience are essential in deciding the appropriate course of action in the absence of specific direction from the Manual itself. This is especially true if the user is deviating significantly from any recommendations in the Manual. Similarly, municipalities may need to adopt policies that reflect local conditions and context. The traffic practitioner's fundamental responsibility is to exercise good engineering judgement that is in the best interests of the public. Guidelines are provided in the OTM to supplement professional experience and assist in making those judgments.

This manual also refers to various publications and primary references produced by MTO and other agencies such as the Institute of Transportation

Engineers (ITE), the Transportation Association of Canada (TAC) and the Ontario Traffic Council (OTC). The guidelines developed in Book 18 also were informed by primary cycling design references from the United States published by the National Association of City Transportation Officials (NACTO) and the American Association of State Highway and Transportation Officials (AASHTO).

1.2 Sections of this Book

This Manual is organized in the following order:

- **Section 1 - General Information:** This section includes introductory information on the purpose of the Manual as well as key highlights. The section presents relevant background and policy information plus a description of each of the Sections found within Book 18.
- **Section 2 - Bikeway Network Planning:** This section provides transportation professionals with a framework for the planning of an urban or rural bicycle network. Section 2 contains overarching active transportation planning concepts that should be incorporated into a municipal transportation or cycling master plan. Establishing a planning framework for cycling is important to guide bicycle facility selection, the application of bicycle facility designs and traffic control devices that are appropriate for a given location or context.
- **Section 3 - Bicycle Facility Type Selection:** This section presents a Bicycle Facility Type Selection tool that bridges the gap between route selection and infrastructure design. It includes a facility selection process, and also discusses context sensitive design considerations.
- **Section 4 - Bicycle Facility Design:** This section provides practitioners with the information necessary to design on-road and in-boulevard bicycle facilities. It includes general geometric considerations, appropriate signage and pavement markings as well as intersection treatments.
- **Section 5 - Additional Bicycle Facility Design Applications:** This section discusses additional bicycle facility design considerations such as bicycle priority streets and traffic calming measures, plus the integration of bicycle facilities at roundabouts, interchanges, ramp crossings, conflict zones, bridge structures and railway crossings.
- **Section 6 - Implementation Process:** The fundamental principles outlined in Section 2 (Bikeway Network Planning), Section 3 (Bicycle Facility Type Selection) and Section 4 (Bicycle Facility Design) are brought together in this section. It outlines a suggested strategy for implementing a bicycle network, and is based on best practices from across North America. This section presents a recommended process, including a management structure and a set of steps considered important to support the review, approval, design and implementation of bicycle facilities on or in the boulevard of public roadways.
- **Section 7 - Support Features:** This section provides a description and examples of supplemental features which should be considered for the enhancement and promotion of cycling. These include bicycle parking, end-of-trip facilities and rest areas, as well as emergency and service vehicle access.

- **Section 8 – Maintenance Strategies for Bicycle Facilities:** This section provides relevant information and strategies for ensuring the safe and efficient operation of on-road and in-boulevard bicycle facilities that are within the road right-of-way.
- **Appendix A - Glossary**

1.3 Bicycle Features & Rules of the Road

The Ontario Highway Traffic Act (HTA) defines the rules of the road, and identifies the rights and responsibilities of motor vehicles, cyclists and pedestrians. Currently the HTA defines a bicycle (including electric-assisted e-bikes) as a vehicle. Tricycles and unicycles are also considered to be 'bicycles', but those that are motor-assisted, such as mopeds, are excluded from this category. As such, cyclists must comply with the rules of the road in the same manner as a motorist.

Bicycles can be operated on most roadways in Ontario, with the exception of the 400 series highways and other roadways to which access has been restricted through Municipal By-laws. Cyclists in Ontario are not required to have a driver's license, and there are no age restrictions to operate a bicycle. The legislation also states that a cyclist must wear a bicycle helmet if under 18 years of age and operating their bicycle on the road.

The HTA generally treats bicycles like any other vehicle. **Table 1.1** outlines the bicycle specific rules of the road contained in the HTA.

Table 1.1 – Bicycle Specific Rules of the Road

Situation	Rights and Duties	HTA Section
Lights and reflectors on bicycles, etc.	"When on a highway at any time from one-half hour before sunset to one-half hour after sunrise and at any other time when, due to insufficient light or unfavourable atmospheric conditions, persons and vehicles on the highway are not clearly discernible at a distance of 150 metres or less, every motor-assisted bicycle and bicycle (other than a unicycle) shall carry a lighted lamp displaying a white or amber light on its front and a lighted lamp displaying a red light or a reflector approved by the Ministry on its rear, and in addition white reflective material shall be placed on its front forks, and red reflective material covering a surface of not less than 250 millimetres in length and 25 millimetres in width shall be place on its rear."	62 (17)
Brakes on bicycle	"No person shall ride a bicycle on a highway unless it is equipped with at least one brake system acting on the rear wheel that will enable the rider to make the braked wheel skid on dry, level and clean pavement."	64 (3)
Alarm bell to be sounded	"Every motor vehicle, motor assisted bicycle and bicycle shall be equipped with an alarm bell, gong or horn, which shall be kept in good working order and sounded whenever it is reasonably necessary to notify pedestrians or others of its approach."	75 (5)
Bicyclists to wear helmet	"No person shall carry a passenger who is under sixteen years of age on a motorcycle on a highway unless the passenger is wearing a helmet that complies with the regulations and the chin strap of the helmet is securely fastened under the chin." "Subject to subsection 103.1 (2), no person shall ride on or operate a bicycle on a highway unless the person is wearing a bicycle helmet that complies with the regulations and the chin strap of the helmet is securely fastened under the chin."	104 (2) 104 (2.1)
Riding in pedestrian crossover	"No person shall ride a bicycle across a roadway within a pedestrian crossover."	140 (6)
Signal for left or right turn	"The driver or operator of a vehicle upon a highway before turning to the left or right at any intersection or into a private road or driveway or from one lane for traffic to another lane for traffic or to leave the roadway shall first see that the movement can be made in safety, and if the operation of any other vehicle may be affected by the movement shall give a signal plainly visible to the driver or operator of the other vehicle of the intention to make the movement."	142 (1)

Situation	Rights and Duties	HTA Section
Mode of signalling turn	"The signal required in subsections (1) and (2) shall be given either by means of the hand and arm in the manner herein specified or by a mechanical or electrical signal device as described in subsection (6)."	142 (3)
How to signal manually	<p>"When the signal is given by means of the hand and arm, the driver or operator shall indicate his or her intention to turn,</p> <p>(a) to the left, by extending the hand and arm horizontally and beyond the left side of the vehicle; or</p> <p>(b) to the right, by extending the hand and arm upward and beyond the left side of the vehicle.</p> <p>Despite clause (4) (b), a person on a bicycle may indicate the intention to turn to the right by extending the right hand and arm horizontally and beyond the right side of the bicycle."</p>	142 (4) 142 (5)
Signal for stop	<p>"The driver or operator of a vehicle upon a highway before stopping or suddenly decreasing the speed of the vehicle, if the operation of any other vehicle may be affected by such stopping or decreasing of speed, shall give a signal plainly visible to the driver or operator of the other vehicle of the intention to stop or decrease speed,</p> <p>manually</p> <p>(c) by means of the hand and arm extended downward beyond the left side of the vehicle; or</p> <p>signalling device</p> <p>(d) by means of a stop lamp or lamps on the rear of the vehicle which shall emit a red or amber light and which shall be actuated upon application of the service or foot brake and which may or may not be incorporated with one or more rear lamps. R.S.O. 1990, c. H.8, s. 142 (8)."</p>	142 (8)
Yielding to pedestrians	"When under this section a driver is permitted to proceed, the driver shall yield the right of way to pedestrians lawfully within a crosswalk."	144 (7)
Riding in crosswalks prohibited	"No person shall ride a bicycle across a roadway within or along a crosswalk at an intersection or at a location other than an intersection which location is controlled by a traffic control signal system."	144 (29)
Vehicles meeting bicycles	"Every person in charge of a vehicle on a highway meeting a person travelling on a bicycle shall allow the cyclist sufficient room on the roadway to pass."	148 (4)
Bicycles overtaken	"Every person on a bicycle or motor assisted bicycle who is overtaken by a vehicle or equestrian travelling at a greater speed shall turn out to the right and allow the vehicle or equestrian to pass and the vehicle or equestrian overtaking shall turn out to the left so far as may be necessary to avoid a collision."	148 (6)

Situation	Rights and Duties	HTA Section
Towing of persons on bicycles, toboggans, etc., prohibited	"No driver of a vehicle or street car shall permit any person riding upon a bicycle, coaster, roller skates, skis, toboggan, sled or toy vehicle to attach the same, himself or herself to the vehicle or street car."	160
Clinging to vehicles, bicycle passengers, etc. Bicycle riders, etc., clinging to vehicles	"A person riding upon a motor assisted bicycle, a bicycle, a coaster, roller skates, skis, a toboggan, a sled or a toy vehicle shall not attach it, them, himself or herself to a vehicle or street car on a roadway."	178 (1)
Bicycle passengers	"No person riding on a bicycle designed for carrying one person only shall carry any other person thereon."	178 (2)
Persons clinging to vehicles	"No person shall attach himself or herself to the outside of a vehicle or street car on a roadway for the purpose of being drawn along the roadway."	178 (4)
Duties of pedestrian when walking along highway	Note: A dismounted cyclist is considered a pedestrian.	
	<p>"Where sidewalks are not provided on a highway, a pedestrian walking along the highway shall walk on the left side thereof facing oncoming traffic and, when walking along the roadway, shall walk as close to the left edge thereof as possible."</p> <p>"Subsection (1) does not apply to a pedestrian walking a bicycle in circumstances where crossing to the left side of the highway would be unsafe."</p>	<p>179 (1)</p> <p>179 (2)</p>
Regulating or prohibiting use of highway by pedestrians, etc.	"Bicycles are prohibited on designated freeways such as the 400 series, the QEW, Ottawa Queensway and on roads where "No Bicycle" signs are posted by regulation (i.e. Reg 630) or municipal by-law."	185 (1)
Prohibiting motor assisted bicycles, etc., on municipal highways	"The council of a municipality may by by-law prohibit pedestrians or the use of motor assisted bicycles, bicycles, wheelchairs or animals on any highway or portion of a highway under its jurisdiction."	185 (2)
Cyclist to identify self	"A police officer who finds any person contravening this Act or any municipal by-law regulating traffic while in charge of a bicycle may require that person to stop and to provide identification of himself or herself."	218 (1)
	"Every person who is required to stop, by a police officer acting under subsection (1), shall stop and identify himself or herself to the police officer."	218 (2)

1.4 The Design Domain Concept

Throughout OTM Book 18, practitioners are encouraged to design bicycle facilities within a design domain. This concept was first introduced in the *TAC Geometric Design Guide for Canadian Roads*. The design domain can be viewed as a range of values that a practitioner may choose for a particular design parameter. It provides the practitioner with some flexibility to design a bicycle facility for the appropriate conditions, rather than to meet a rigid standard.

It is very important that a practitioner designing a bikeway facility understands the design process including the rationale and justification for providing a particular treatment. Practitioners should refer to **Sections 2 and 3** to better understand the processes involved in Bikeway Network Planning and Bicycle Facility Type Selection.

For each design parameter, the most appropriate value should be chosen based on several considerations, including:

- Facility function;
- Available right-of-way;
- Traffic volume;
- Posted and observed speed;
- Perceived user comfort and safety level;
- Actual collision risk; and
- Cost.

The practitioner is responsible for designing facilities through the use of good engineering judgement. This requires experience, insight and an understanding of local conditions.

The design domain is applied primarily to the lane widths of a bikeway facility. It is presented as a

‘desired width’ and a ‘suggested minimum’ value. It is recommended that the practitioner design to the desired width. However, through the use of good engineering judgement, the designer may consider implementing a width that is less than the desired value, but no lower than the suggested minimum for context specific situations and segments or corridors with constrained rights-of-way. Also, practitioners may choose to design to a standard that is wider than the desired dimensions based on an assessment of the conditions and other considerations.

Designers are strongly recommended to document their rationale at all stages of the facility selection and design process. This is particularly important where proposals deviate from the desired widths, which are considered optimal from a safety perspective. This will assist the designer should they be required to defend any compromises they may have chosen for operational, cost or other reasons based on their engineering judgement.

Practitioners should refer to the *TAC Geometric Design Guide for Canadian Roads* sections 1.1.5 and 1.1.6 for further information on the concept of a design domain.

1.5 Cycling Myths

There are a number of misconceptions regarding safety associated with bicycle transportation. With the evolution of bicycle planning and facility design, experts have identified and summarized several of these myths in the sections below.

Myth #1: Cycling on Sidewalks is Desirable

Cycling should almost never be mixed with pedestrian traffic on sidewalks. The only exception is for children (typically under the age of 11) who may lack the necessary skills and cognitive abilities

to operate a bike on a roadway with motor vehicle traffic.

Cycling on a sidewalk is strongly discouraged because of the mobility constraints and varying abilities of pedestrians and cyclists. Cyclists travel at much higher speeds than pedestrians, yet they cannot change their direction or speed as quickly as a pedestrian can. There are also numerous fixed objects on or adjacent to a sidewalk around which cyclists must navigate. These include parking meters, utility poles, sign posts, transit shelters, benches, trees, fire hydrants and mail boxes. In general, cyclists should have access to dedicated or bicycle-friendly facilities.

Other conflicts that cyclists encounter while riding on a sidewalk include pedestrians alighting from buses, exiting stores and emerging from parked cars. Such situations do not allow enough time for cyclists to avoid a collision. Pedestrians, on the other hand, can find it difficult to predict the intended direction of an oncoming or overtaking cyclist.

When cyclists use sidewalks to travel in the opposite direction to the adjacent motor vehicle flow, conflicts occur more frequently at driveways or intersecting streets. This is because drivers who exit these areas are not looking for cyclists, who travel at higher speeds than pedestrians. The risks to cyclists are similar to those for raised cycle tracks, in-boulevard facilities and separated bike lanes described in **section 5.4.1.2**. However, they are amplified since the lack of a formal cycling facility and associated signing makes drivers less likely to expect cyclists to be crossing.

Finally, sidewalks are typically 1.5 metres wide which is the minimum width of an on-street bicycle lane. Thus, any manoeuvring by the cyclist to avoid pedestrians, fixed objects or oncoming cyclists would require them to either stop or leave the sidewalk.

In residential areas, it is common for children to ride their bicycles on sidewalks. This type of cycling is appropriate, however these sidewalks should not be signed as bicycle paths or routes.

Myth #2: On-Street Cycling is not Safe

Statistically, off-road facilities have a higher incidence of bicycle collisions with motor vehicles or pedestrians at cross streets and driveways, particularly in commercial areas, compared to on-road cycling.

Many off-road facilities have been built with poor sight lines, severely limited recovery areas and sharp deflections in the alignment at bridges, sometimes with slippery threshold plates at the abutment. Often there are accumulations of sand, debris and eroded materials on separated bicycle facilities since they do not get swept as regularly as on-street bicycle lanes. These frequently lead to incidents which do not involve another vehicle or cyclist.

It could be argued that the higher risk of collisions on bike paths is offset by the lower average severity of injuries suffered compared to those associated with on-street collisions with motor vehicles. This is a complex issue that is beyond the scope of this manual. However, the blanket statement that “on-street cycling is not safe” should **not** be accepted by practitioners. The full range of available facilities (as outlined in **Section 4**) should be considered by the designer, and the most appropriate one should be selected for each particular site.

Myth #3: Riding Against Traffic is Safer

Riding in the roadway against the flow of traffic is one of the leading causes of cyclist fatalities, especially among children. Pedestrians are encouraged to walk against the flow of traffic so

that drivers and pedestrians can see each other, but this is not as effective for cyclists. Motorists are not expecting cyclists to be travelling against the flow of traffic, particularly at intersections. It is also more difficult for motorists to react in time and take evasive action because the speed of cyclists is much higher than that of pedestrians. It is much safer for a cyclist to travel with the flow of traffic and be equipped with bright clothing, reflectors and lights. A rear-view mirror is recommended; in the absence of one, cyclists should check over their shoulder to see that it is safe before commencing a manoeuvre.

Myth #4: Cyclists Can Dismount and Walk as Necessary

It is sometimes necessary for cyclists to dismount their bicycle and walk when the terrain or cycling conditions are difficult and no alternatives exist. However, the option of asking cyclists to dismount and walk their bikes should not be relied upon in lieu of adequately accommodating cyclists through appropriate road design. Being propelled by muscular power, cyclists more than other vehicle operators will prefer to sustain their momentum and avoid stopping. Cyclists usually find it difficult to rationalize why “dismount and walk” restrictions are in place, and conclude that they were a poor, illogical or arbitrary decision. Thus, if facility designs cause cyclists to make what they consider to be unnecessary stops, this will increase the likelihood that they will ignore or disobey traffic controls, which breeds disrespect for these devices.

Myth #5: All Cyclists are the Same

Cyclists come in all shapes and sizes, and have a wide range of ages and skill levels. Furthermore, utilitarian and recreational cyclists have distinct priorities that result in wide variations in travel

speed, route choice, facility preference and perception of risk.

If bicycle facilities are designed for only one type of cyclist, such facilities may be underutilized by other cyclist types. For example, utilitarian commuter cyclists travelling at speed on an active transportation path with high pedestrian volumes may create a hazard. A bicycle facility on an arterial or major collector road may be considered hazardous for use by young or inexperienced cyclists. Each age group has its own characteristics, its own collision patterns, and its own needs. See **Section 2.1.2** for further information on cyclist types.

Myth #6: Multi-use Paths are Acceptable for All Recreational Users

Active transportation paths, often referred to as in-boulevard multi-use paths or trails, are similar to sidewalks but are wider and designed to accommodate cyclists, pedestrians and other users in a common off-road shared facility. As a general principle, there needs to be adequate space for pedestrians and cyclists to safely co-exist where shared facilities are being proposed. Where space permits, separate pedestrian and cycling facilities should be considered.

Other active transportation users such as in-line skaters and skateboarders may utilize multi-use trails depending on the surface type. As a rule, motorized vehicles are prohibited from off-road multi-use trails; however, snowmobiles and all-terrain vehicles may be permitted on some trail systems.

Providing the same path for horses and bicycles creates an unsatisfactory and possibly very dangerous mix. Horses startle easily and may change direction suddenly if they perceive cyclists as a danger. Bicycle facilities and horse trails are

also incompatible in their surface requirements. Bicycles function best on hard surfaces; for horses, soft surfaces are preferable. As a result, separate equestrian and bicycle facilities should be provided.

Myth #7: Cyclists do not ride in the Winter Season

Cycling is a viable mode of transportation and recreation year round, including in the winter season. While cycling volumes decrease from December to March, in many parts of Ontario large numbers continue to cycle through the winter. This is particularly true of commuters, who may rely on cycling to travel to and from work since they have no alternative form of transportation. Participating in cycling activities over the winter also allows cyclists to continue reaping the health benefits of increased physical activity that they enjoy the rest of the year.

The main challenge for cyclists in the winter season is unfavourable weather conditions such as snow and ice, which must be managed to ensure a safe riding experience. Municipalities without a winter maintenance strategy for cycling infrastructure are encouraged to develop one. In many jurisdictions, winter maintenance is often integrated into the operating costs of bike facilities.

In Sweden, where winters are comparable to here in Ontario, winter cyclist volumes can be more than a third of those recorded during the summer. However, volumes on bikeways with leftover snow and ice are significantly lower than on those that have been fully cleared. Maximizing the utilization of cycling infrastructure year-round can minimize the additional winter demand transferred to other

transportation systems, whose capacity may also be affected by the conditions.

Practitioners should note that bicycle facilities can actually have cost-saving effects. For example, bike lanes keep heavier motor vehicles away from drainage grates and other curbside infrastructure. The pavement in that area is particularly vulnerable to damage that may be exacerbated by the freeze-thaw conditions, and the need for remedial works is therefore reduced. Information on maintenance strategies and considerations can be found in **Section 8.**

2. Bikeway Network Planning

Cycling is an extremely efficient means of transportation but, like any other mode of travel, there are risks associated with operating a bicycle. Cyclists, like pedestrians, are considered vulnerable road users since they are at a greater risk of injury in collisions with motor vehicles. It is important that planners and designers consider the needs of cyclists and motorists, while following accepted road safety and geometric design guidelines.

While all roadways should be accessible for cycling, except where prohibited by law, not all roadways are appropriate for all cyclists. Bicycle facility planning consists of selecting candidate routes which are part of an overall bikeway network that meets the needs of potential cyclists. Individual routes may be more appropriate for a particular group of cyclists based on the roadway characteristics and facility type. However, the overall bikeway network should be selected, planned and designed with all potential cyclists in mind.

Bikeway network planning should occur in advance of bicycle facility type selection (**Section 3**) and bicycle facility design (**Section 4**). Bikeway network planning can also help to achieve effective implementation of cycling network projects (**Section 6**).

The information in this chapter outlines the key concepts when planning, selecting and designing appropriate bicycle facilities. These concepts include:

- Bicycle User Characteristics;
- Bicycle Operating Requirements;
- Bicycle Facility Types; and
- Route Selection Criteria.

2.1 User Characteristics

A cycling network should provide a clear, well-defined and comfortable environment for all anticipated users. Therefore, it is important to identify the primary target groups for whom the facility is being designed. Cyclists can generally be grouped according to age, skill level, comfort zone and trip purpose.

2.1.1 Age

A well-planned cycling network should consider the needs of users of all ages.

Adults:

- Tend to cycle for longer periods of time but distances vary depending on the purpose of the trip;
- Cycle for both utilitarian and recreational purposes, although this is typically dependent on the time of year. Utilitarian (particularly commuter) cycling rates typically dominate in winter months; and
- Skill and comfort level typically determine the facility and street type on which they choose to ride.

Children / Young Adults / Seniors:

- Unlikely to go on longer trips, and tend to engage in short distance cycling activities;
- Distance travelled varies from less than 1 kilometre for young children to over 5 kilometres for older children and young adults;

- Cycle for utilitarian purposes, such as riding to visit friends, to school or to run errands;
- Cycle for recreational purposes, perhaps using a trail, park or other such facility within their neighbourhood;
- More likely to ride on residential or low volume streets and trails;
- Less visible to motorists because they are smaller in stature and ride smaller bicycles; and
- Riding skill and judgement are not as developed compared to older cyclists.

‘Enthusied and Confident’ cyclists are those who are comfortable sharing the roadway with vehicular traffic but prefer to do so within their own designated area with pavement markings and signage for the preferential or exclusive use of cyclists.

Many studies have shown that the number one reason people do not ride bicycles is because they are not comfortable riding on the roadway with motorized vehicles. **‘Interested but Concerned’** describes people who:

- Avoid cycling in areas with medium to high volumes of motor vehicle traffic;
- Become discouraged by high-speed traffic, extreme topographic conditions and inconsistent bicycle facilities;
- Ride infrequently, typically around their immediate neighbourhood but are curious about cycling and would like to ride more;
- May not have their own car, for example children or teenagers who would like to cycle to school or other activities but they (or their parents) are concerned for their safety; and
- May be attracted to cycling by the implementation of designated facilities, particularly separated and in-boulevard bicycle facilities which provide more space between cyclists and motorists.

2.1.2 Skill and Comfort Level

Practitioners should consider the skill and comfort level of cyclists when deciding to implement a bicycle network and when choosing the appropriate bicycle facility type. The Portland Bicycle Plan suggests that cyclists can be categorized into one of the following four groups: ‘Strong and Fearless’, ‘Enthusied and Confident’, ‘Interested but Concerned’ and ‘No Way, No How’, a characterization which is widely accepted by designers and cycling groups throughout North America.

‘Strong and Fearless’ cyclists:

- Tend to ride more frequently;
- Will typically cycle for both utilitarian and recreational purposes;
- Have advanced cycling skills and are comfortable riding alongside motorized traffic; and
- Will cycle regardless of roadway conditions, although users in this group may prefer to use on-street bike lanes.

The **‘No Way, No How’** group represents people who are not, and may never be, interested in cycling. This may be related to their local topography, a lack of skills or capability, or just that they have not and would not consider cycling for transportation.

It should be noted that this categorization addresses only their willingness to use a bicycle as a main means of transportation. However, people in all these groups, especially the 'Interested but Concerned' group, may also cycle for recreation.

about 8% of the population. The target market for practitioners promoting the expansion of cycling should be the 'Interested but Concerned' group. These people comprise 60% of the population and would cycle more if the facilities were in place to help them to feel safe on their bikes.

Figure 2.1 is an example of the typical distribution of the four types of cyclist that can be found in an urban municipality. Development of the cycling network should improve the experience of the 'Strong and Fearless' and the 'Enthusied and Confident' groups, however these only represent

Figure 2.1 – Four Types of Cyclist

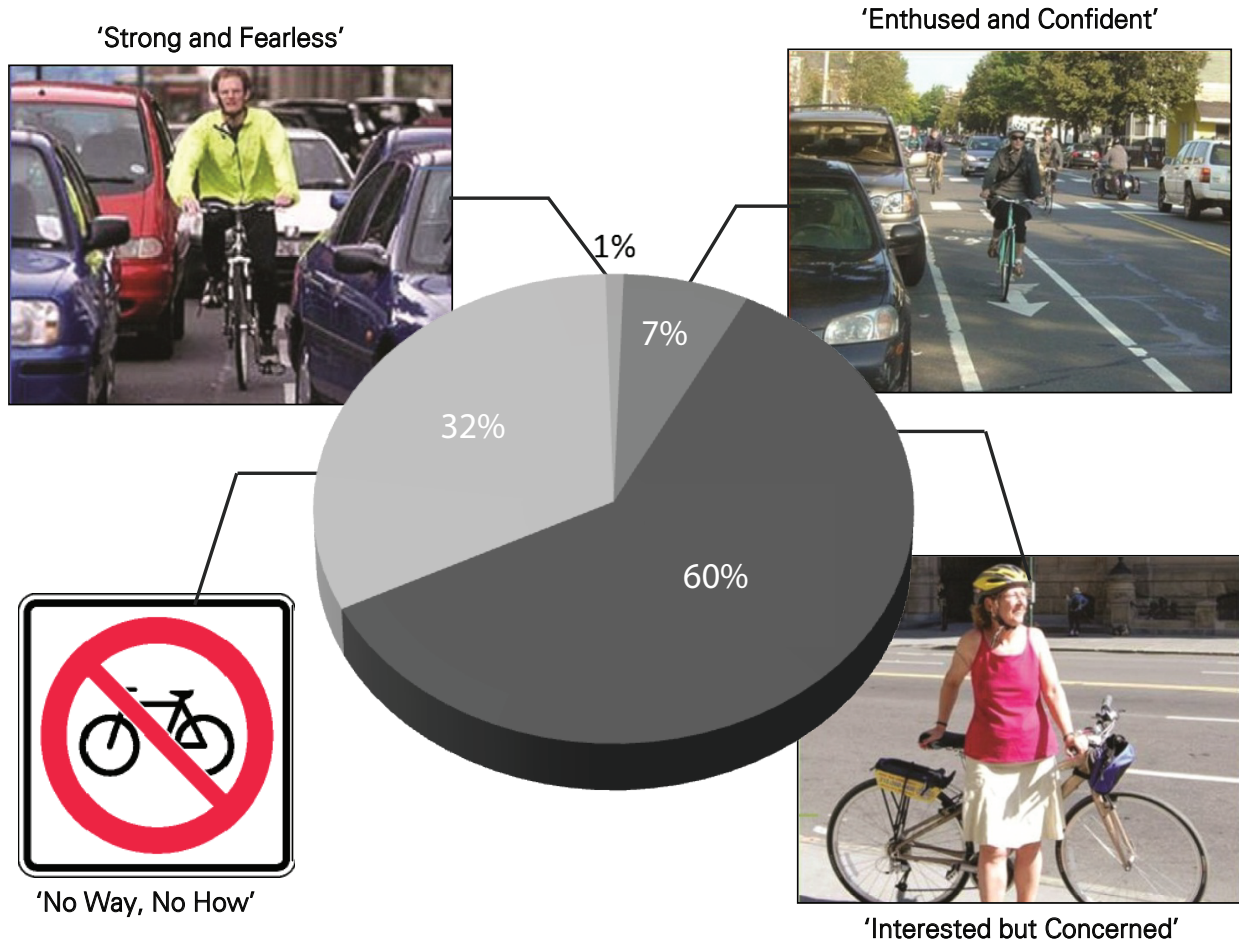

Source: ALTA Planning & Design, 2010 - Based on information from the City of Portland, Oregon, 2010

2.1.3 Trip Purpose

Generally, cycling trips can be divided into three categories: **Utilitarian**, **Recreational** and **Touring**.

- **Utilitarian** or destination-oriented trips are for the purpose of reaching a particular destination and are often repetitive. These include trips to places of employment (commuting), to school or to shops, plus trips that are necessary as part of an individual's daily activities. Commuters are concerned with travel time and distance. They generally prefer to take the most direct route, which may include major roadways, although they also favour routes with as few traffic signals and stop signs as possible. Commuter cyclists may use bike paths, but only if the routes lead directly to their destination with few interruptions.
- **Recreational trips** are identified by the level of enjoyment, scenery and company of other cyclists. Recreational riders generally avoid higher volume arterials and collector roads, and ride on off-road bicycle facilities, quiet neighbourhood streets or rural roadways. Fitness and sport cyclists ride for exercise and skill training. Trips can be taken alone or in groups, simulating race conditions in order to improve their skill and fitness level. These cyclists prefer to ride on low volume rural roadways with minimal traffic interruptions.
- **Touring trips** are often longer than utilitarian or recreational trips. Touring cyclists prefer to ride on rural roads or major trails with ample scenery. Trips are generally between urban areas or to specific points of interest. Touring trips require more planning since the route, destinations and accommodation are important factors for the cyclist.

2.1.4 Other Potential Users

OTM Book 18 focuses on designing facilities for cyclists. As a result, it does not include the details of facility types for other road users. However, consideration should be given to other possible users when choosing facility types and designing cycling connections or networks. These users may include pedestrians (both able-bodied and those using powered mobility aids), in-line skaters and skateboarders, as well as riders of electric bikes, electric scooters and Segways.

2.2 Bicycle Operating Requirements

The operating space for cyclists is an important factor in bikeway facility design. Cyclists need a certain amount of space to maintain stability. The operating space is determined by examining typical bicycle dimensions, space requirements for manoeuvring, horizontal clearance and vertical height. Operating characteristics vary considerably from cyclist to cyclist due to differing types of bicycles, varying abilities or the surrounding environment. This latter category includes traffic volumes, vehicle mix, speed, geometric alignments and topographical conditions.

An operating width of 1.2 to 1.5 metres is sufficient to accommodate the forward movement of the majority of cyclists. This dimension is greater than the actual width occupied since it takes into account the natural side-to-side movement that can vary according to speed, wind and the ability of the cyclist.

Manoeuvring space requirements can vary from 0.1 to 0.45 metres on each side of the physical envelope. In addition, to ride comfortably and avoid fixed objects such as curbs, bridge abutments and railings, a cyclist needs a minimum of 0.25 metres

of horizontal clearance from the closest edge of the bicycle facility to the rigid or conflicting object or hazard. A 0.5 metre clear zone should be provided behind the vertical face of curb plus a width of 0.5 metres alongside the outer edge of the bicycle facility. This should be graded and free of stationary objects. The operating height of 2.5 metres can generally accommodate an average adult cyclist standing upright on the pedals of a bicycle. **Figure 2.2** illustrates the typical operating space required for a cyclist on the roadway.

Figure 2.2 – Cyclist Operating Space

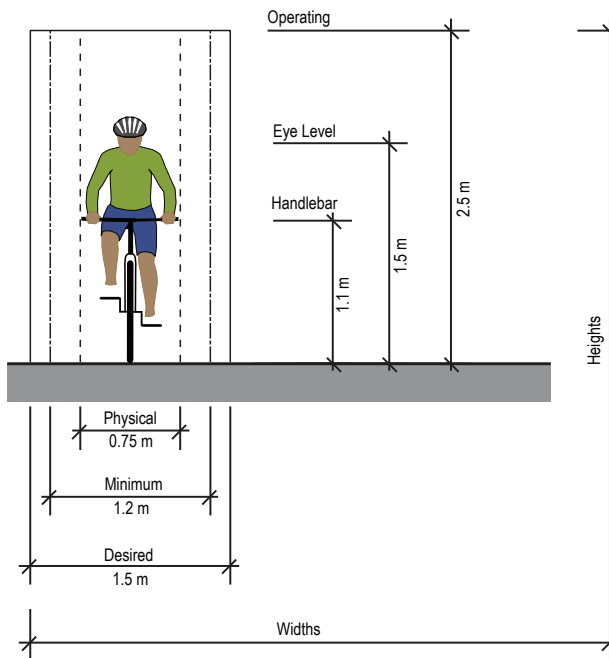

Based on information from the AASHTO Guide for the Planning, Design and Operation of Bicycle Facilities, 2012

In addition to having well-planned and designed bicycle facilities, it is important to have supporting policies with regard to education, encouragement, enforcement and bicycle training programs. Please refer to the **Bicycle Facility Selection Tool** in **Section 3** for more information regarding user risk and bicycle facility type selection.

2.3 Types of Bicycle Facilities

A complete cycling network typically consists of various types of bicycle facilities which accommodate different user characteristics and trip purposes. Each bicycle facility type within the right-of-way can be organized into two categories: **on-road** and **in-boulevard**.

Please note that there may be other variations of these bicycle facility types beyond those discussed in these guidelines. This document focuses on a variety of facility types which are summarized as follows:

On-Road Bicycle Facilities:

- Shared Roadway and Signed Only Bicycle Route
- Signed Bicycle Route with Paved Shoulder
- Conventional Bicycle Lane
- Separated Bicycle Lane
- Raised Cycle Track
- Bicycle Priority Streets

In-Boulevard Bicycle Facilities:

- Active Transportation / Multi Use Path
- Raised Cycle Track

Note that the Raised Cycle Track appears in both categories. A raised cycle track can be within the roadway if it is between the curbs but slightly elevated. It can also take the form of a one-way or two-way in-boulevard facility beyond the curbs.

2.3.1 On-Road Bicycle Facilities

2.3.1.1 Shared Roadways and Signed Bicycle Routes

Unless cycling is specifically restricted, all roadways are considered to be Shared Roadways where both motorists and cyclists share the same vehicular travel lane.

On a shared roadway that has been designated as a bicycle route, green marker signs should be installed. This is required for all formal, continuous bicycle facilities for awareness, consistency and wayfinding purposes. Where the marker sign is the only bicycle-related provision, this is known as a 'Signed Only' route.

While a bicycle may operate on any shared roadway, a 'Signed Only' bike route is typically only considered for local urban and suburban roads where traffic volumes and vehicle operating speeds are low. As motor vehicle traffic volumes increase, the width of the shared travel lane may be increased. However, this may result in higher motor vehicle speeds and associated safety risks, hence upgrading to a formal bicycle facility such as a conventional bicycle lane is preferred whenever feasible.

Shared use lane markings (sharrows) may be applied as an option. Sharrows are intended to indicate to both motorists and cyclists the appropriate line of travel for cyclists. Where shared lanes are sufficiently wide for cyclists to ride alongside motorists, sharrows are applied near the curb. Where shared lanes are too narrow for this, the sharrows are placed in the centre of the lane.

In the two aforementioned cases, practitioners may install 'Share the Road' and 'Shared Use Lane Single File' signs respectively. Where a sharrow or similar treatment is provided to guide cyclists

Figure 2.3 – Shared Roadway with Sharrows



Note: Sharrows are intended to indicate to both motorists and cyclists the appropriate line of travel for cyclists.

Credit: New River Valley Bicycle Association, 2011

through specific locations such as intersections, bicycle route marker signs may be omitted. Refer to **Section 4.1.1** for more detailed information regarding the design of Shared Roadways and Signed Bike Routes.

2.3.1.2 Signed Bicycle Route with Paved Shoulder

This is a road with a rural cross section which is signed as a bike route that also includes a paved shoulder. A paved shoulder is a portion of a roadway which is contiguous with the travelled way, and is used to accommodate stopped vehicles, emergency use, pedestrians and cyclists as well as for lateral support of the pavement structure. A paved shoulder on a designated bike route may include a buffer zone to provide greater separation between motorists and cyclists travelling in the same direction.

A signed bike route with a buffered paved shoulder is typically recommended on rural secondary

Figure 2.4 – Paved Shoulder – Dufferin County



Note: The paved shoulder is adjacent to the vehicular travel lane and provides cyclists with a riding space further away from motor vehicle traffic.

Credit: MMM, 2009

Figure 2.5 – Conventional Bicycle Lane, Milton Trails



Note: Sufficient space should be provided to mitigate conflict between cyclists and opening car doors on streets where on-street parking is permitted

Credit: MMM

highways, arterials or collectors. The buffer can be made up of two edge lines with or without diagonal hatching. A rumble strip may be provided between the edge lines if it is deemed necessary for the safety of motorists; however, the spacing and shape of the grooves should be as bicycle-friendly as possible. The buffer provides added separation between cyclists and motorists, offering both user groups more comfort as they travel along the roadway. Refer to **Section 4.1.2** for more information.

2.3.1.3 Conventional Bicycle Lane

This is a portion of a roadway which has been designated by pavement markings and signage for the preferential or exclusive use of cyclists.

A bicycle lane is typically located on urban arterial or collector roadways that have higher traffic volumes, operating speeds and proportion of commercial vehicles compared to local urban

roadways. Bicycle lanes should typically be provided on both sides of two-way streets. On one-way streets, conventional bike lanes operate in the direction of travel. As described in **Section 2.3.1.5**, in a contraflow scenario the bike lane operates in the opposite direction to the flow of motor vehicles. If on-street parking is permitted, the bicycle lane is typically placed between the parking area and the travel lane. However, some municipalities are experimenting with the location of the bicycle lane by placing it between the curb and permanent on-street parking, thereby creating a form of separated bicycle lane. Either way, sufficient space should be provided to mitigate conflicts between cyclists and opening car doors.

The space reserved for the preferential or exclusive use of cyclists is defined by one or, in some cases, two longitudinal pavement markings plus a diamond followed by a bicycle symbol indicating that the lane is reserved. Refer to **Section 4.2.1** for further

guidance on the design of Conventional Bicycle Lanes, including signage requirements.

2.3.1.4 Separated Bicycle Lane

This is a portion of a roadway which has been designated for the exclusive use of cyclists by signage along with a physical or marked buffer. This facility type provides additional spatial or physical separation between motorists and cyclists.

Figure 2.6 – Separated Bicycle Lane



Note: Separation restricts the encroachment of motorized traffic, and is perceived to create a more secure and comfortable environment for cyclists.

Credit: SFstreetblog.org, 2009 (left photo)
 Credit: City of Vancouver (right photo)

A separated bicycle lane, also sometimes referred to as a ‘segregated bicycle lane’ may be separated by a buffer with hatched pavement markings or by a physical barrier such as a line of bollards, a median or parked vehicles. Physical separation restricts the encroachment of motor vehicle traffic into the separated bicycle lane, and is perceived to create a more secure and comfortable environment for cyclists. It may, however, restrict a cyclist’s ability to manoeuvre into or out of the lane midblock. Where a roadway allows on-street parking, the

separated bicycle lane may be positioned between the parking lane and the curb. A separated bicycle lane is typically used for utilitarian purposes. Refer to **Section 4.2.2** for further guidance on the design of Separated Bicycle Lanes.

2.3.1.5 Contraflow Bicycle Lane

Cyclists riding within a Contraflow Bicycle Lane travel in the opposite direction to motor vehicle traffic. A Contraflow Bicycle Lane enables two-way bicycle travel on a roadway that has one-way operation for motor vehicles. It is a type of Conventional Bicycle Lane or Separated Bicycle Lane that simply operates in the opposite direction to the normal flow of traffic.

A Contraflow Bicycle Lane is typically implemented to provide greater connectivity within a bikeway network where the route using regular bicycle facilities would be much longer. Refer to **Section 4.2.3** for further guidance on the design of Contraflow Bicycle Lanes.

2.3.1.6 Raised Cycle Track

This is a bicycle facility adjacent to but vertically separated from motor vehicle travel lanes. A raised cycle track is designated for exclusive use by cyclists, and is distinct from the sidewalk.

A raised cycle track is typically implemented on high volume urban arterial or collector roadways with high bicycle traffic volumes. Raised cycle tracks are typically curb separated to the level of the adjacent sidewalk or an intermediate level between that and the roadway.

The raised cycle track may be designed for one-way or two-way travel. Raised cycle tracks are typically used by both experienced and casual cyclists for utilitarian purposes. Refer to **Section 4.3.1** for design guidelines on Raised Cycle Tracks.

Figure 2.7 – Raised Cycle Track in Toronto



Note: A raised cycle track is typically implemented on high volume urban arterial or collector roadways with high bicycle traffic volumes

Credit: MMM, 2013

2.3.1.7 Bicycle Priority Street

Sometimes referred to as a ‘Bicycle Boulevard’ or ‘Local Bicycle Street’, this is a low-volume, low-speed street that has been optimized for bicycle travel through treatments such as traffic calming and traffic reduction by means of signage and pavement markings, as well as intersection crossing treatments. The facility is designed to allow through movements for cyclists while discouraging motorized traffic from taking the same route. This facility is typically implemented on residential streets. Refer to **Section 5.1** for further guidance on the design of Bicycle Priority Streets.

2.3.2 In-Boulevard Bicycle Facilities

2.3.2.1 Active Transportation Path

This is a path that is physically separated from motor vehicle traffic by a strip of grass (often referred to as a “boulevard” or “verge”) or paved ‘splash strip’ within the roadway or highway right-of-way. An Active Transportation Path may be comprised of a bicycle facility that is distinct from the sidewalk, or

Figure 2.8 – Bicycle Priority Street



Note: A bicycle priority street is typically implemented on low volume residential roadways with measures to reduce motor vehicle volume.

Credit: Rich Dhruil

a single path shared by cyclists and pedestrians. In urban areas, an Active Transportation Path is often referred to as an ‘in-boulevard multi-use path’.

Active Transportation Paths provide recreational opportunities but may also provide a direct commuter route in corridors not served by on-road bicycle facilities. Designers should consider access and connectivity restrictions that may result if a facility is only on one side of, and removed from, the roadway. Practitioners should look to mitigate this through the provision of midblock crossing facilities.

An Active Transportation Path is appropriate for both experienced and inexperienced cyclists and, if permitted, other active transportation users such as pedestrians, in-line skaters, skateboarders and wheelchair users. Motor vehicles are not permitted on an Active Transportation Path, except when emergency or maintenance vehicles require access.

Figure 2.9 illustrates a typical cross-section for an Active Transportation Path for use by both cyclists and pedestrians. Refer to **Section 4.4.1** for further

guidance on the design of In-Boulevard Active Transportation Paths.

2.4 Route Selection Criteria

Except where prohibited by law, cyclists are permitted to ride on all roadways. However, some roadway corridors may be more suitable than others for the implementation of bicycle facilities. The process of developing a comprehensive bikeway

Figure 2.9 – An Example of a Shared Use AT Path



Note: Motorized vehicles are not permitted on active transportation paths, except when emergency or maintenance vehicles require access.

Credit: MMM

network involves selecting routes that meet the needs of potential users. Often a set of route selection criteria is used to help practitioners in this process. Several common route selection criteria are described below which should, at a minimum, be considered when selecting candidate routes. The Bicycle Facility Selection Tool in **Section 3** outlines the process which should be undertaken to select the bicycle facility type that best suits a given design situation.

2.4.1 Access and Potential Use

A comprehensive bikeway network is often developed by selecting routes that are located close to the highest proportion of users in order to maximize access and use. Cyclists are more inclined to use a bikeway network if it is located close to key points of origin and destination in a community. Areas with high concentrations of residential, employment, commercial and retail land uses, as well as educational institutions, community centres and recreational areas should be considered as key origin and destination points that may generate cycling trips.

As public transit infrastructure develops, mobility hubs are becoming increasingly significant nodes in the bicycle network. They include train terminals, subway stations, LRT stops and bus interchanges. Mobility hubs are effectively becoming more prominent origin and destination points on the cycling network. Utilitarian cyclists transfer to or from different modes of transportation at these locations. Formalizing bicycle routes that connect residential centres to these nodes will increase the catchment area of the transit network. Such cycling infrastructure will give a larger proportion of Ontario's urban population more rapid and reliable access to their nearest mobility hub than if they made the first or last leg of their journey by foot.

2.4.2 Connectivity and Directness

Candidate routes that are selected to form a bicycle network should improve connections to other modes of transportation and places of interest for cyclists. Candidate routes should add to the completeness of an individual corridor or to the comprehensiveness of the overall bike network. The routes should be distributed in a way that provides the shortest, quickest and most convenient connections between origin and destination points.

In some cases, the selection of facilities for construction is based on opportunities that may arise for synergies with other projects, as outlined in **Table 3.11**. Combining works in this way allows bike facilities to be installed while achieving cost efficiencies, however practitioners should consider the completeness of the resulting bikeway network. The implementation of small sections of disconnected bicycle facilities is unlikely to provide meaningful connections for cyclists since those facilities may suffer from low cycling volumes. Practitioners should consider investing some of the resources saved through the aforementioned synergies to provide additional links that properly integrate the new facilities into the network.

2.4.3 Physical Barriers

In some areas, there may be major physical barriers or constraints to bicycle travel caused by topography, rivers, narrow bridges, freeways, railroad tracks or other obstacles. When selecting candidate routes, preference should be given to routes with few or no barriers or constraints that may affect the connectivity and directness of the bike route. If these constraints are unavoidable for a particular candidate route, consideration should be given as to how such barriers will be overcome, and the associated costs, when comparing alternative routes.

2.4.4 Attractiveness

Scenery is an important consideration for any bikeway network, especially for touring and recreational routes. Candidate routes that are attractive and comfortable to use will improve overall user enjoyment and increase the perception of safety. A high quality cycling experience can be provided in a wide range of settings. Bikeways that serve a primarily recreational purpose may be located beside rivers and ravines, or through hydro rights-of-way; existing or former rail corridors may

also provide an interesting and attractive route. Recreational cyclists tend to favour routes with adjacent land uses that are attractive; utilitarian cyclists will also prefer these routes, provided they are direct.

2.4.5 Safety and Comfort

The safety and risk exposure of cyclists must be considered when selecting candidate routes. The factors that influence the level of safety and risk exposure for a particular bikeway include: user conflicts, traffic volume and speed, truck and bus volumes, on-street parking, surface quality, sightlines, maintenance considerations and human factors. These variables are discussed in detail within the Bicycle Facility Selection Tool in **Section 3**. The roadway and safety characteristics of the candidate route should also be considered.

Pavement surface quality and traffic volumes are factors that may affect a cyclist's comfort level within the bicycle facility. Candidate routes should have a pavement surface that is free of bumps, potholes and other surface irregularities in order to provide users with a comfortable cycling experience. Candidate routes located on heavily travelled or high-speed roadways may be frequently used by experienced utilitarian cyclists, but recreational cyclists may not be comfortable with this type of facility. A parallel route should be selected where possible in order to accommodate those user groups.

2.4.6 Cost

The evaluation of candidate routes will normally involve a cost comparison. This analysis should identify the capital and maintenance costs for the bicycle facility. Consideration should also be given to the feasibility of constructing and implementing the candidate route.

Funding availability can limit choices; however, a lack of funds can never justify a poorly designed, constructed or maintained facility. It is usually more desirable not to build anything than to construct a poorly planned or designed facility. The decision to implement a bikeway should be made with a conscious, long-term commitment to a proper level of maintenance.

2.4.7 Accommodation of Existing and Future Demand

Routes that are established, successful and popular with cyclists should be selected as candidate routes. Local cyclists and stakeholders may also identify routes as an important future connection, and request that additional facilities be constructed to improve the connection. Routes with scenic corridors along abandoned railroads, and roads where shoulders can be paved have a high potential for cycle tourism, and should be considered as candidate routes.

2.4.8 Consistent with Local Tourism Strategies and Goals

When selecting candidate routes, practitioners should review the strategies and goals identified by Regional Tourism Offices and related organizations to ensure that the route supports, and is consistent with, these strategies and goals. These routes should consider primary regional destinations such as Conservation Areas, and may also include important local destinations such as Community Centres, Universities and Historic Sites.

2.5 Bicycle Design Supporting Complete Streets

Complete Streets are roadways which have been designed to be a safe, attractive, accessible and integrated environment for all road users across all modes. Pedestrians, cyclists, motorists and

transit users of all ages and abilities are considered during the design and implementation of Complete Streets.

The benefits include:

- Improved safety for all users;
- More liveable communities;
- Positive impacts on public health; and
- Economic benefits, since people want to be there.

Cycling infrastructure is a key element of the Complete Streets mix. It improves the accessibility of a community and, if effectively planned and designed, allows for seamless transitions between cycling, pedestrian and transit modes.

Corridor projects are a good opportunity for providing continuous bicycle facilities as part of, or in addition to, the planned bikeway network. Combining the provision of bicycle facilities with those for Bus Rapid Transit (BRT) or Light Rail Transit (LRT) planning can lead to implementation synergies and associated cost savings.

2.6 Support Features

There are several key support features which should be considered in the planning and design of bikeway networks. Sometimes these provisions are overlooked, but they often play a key role in providing users a complete bikeway system and encouraging bicycle use.

2.6.1 Bicycle Parking Facilities

Providing bicycle parking facilities is an essential component of a multi-modal transportation system, and is necessary for encouraging more bicycle use. A lack of appropriate bicycle parking supply can deter individuals from considering cycling as their basic mode of transportation.

Adequately designed bicycle parking facilities located in strategic areas allow cyclists to securely lock their bicycles, and can contribute to more orderly sidewalks and parking areas in terms of appearance and flow. Some factors that should be considered when planning and designing bicycle parking include:

- Location of Bicycle Parking Area;
- Visibility and Security;
- Type of Bicycle Parking Facility;
- Weather Protection; and
- Clearance Considerations.

Refer to **Section 8.7** in **Section 8** for information on the maintenance of bicycle parking facilities.

2.6.2 Other End-of-Trip Facilities

In addition to secure bicycle parking, non-residential developments can offer a variety of other end-of-trip facilities such as bike rooms with repair stations as well as shower and change facilities.

2.6.3 Rest Areas

Rest areas should be provided at strategic locations along routes where users are expected to stop, such as lookouts and restaurants, as well as along trails and waterfront promenades. Rest areas can be provided for both rural and urban recreational routes.

2.6.4 Emergency and Service Vehicle Access

Additional consideration should be given to emergency access to physically separated bicycle lanes and in-boulevard facilities. The challenge lies in implementing access configurations that allow the free flow of permitted path users, as well as access for authorized emergency and service vehicles, while blocking unauthorized motor

vehicles. Some options that may be considered for these circumstances include:

- Removable or Retractable Bollards;
- Flex Bollards; and
- Split Path Entrances.

For more information on Support Features, please refer to **Section 7**.

2.7 Information Regarding Maintenance

Maintenance is vital to the effectiveness of bike facilities. In order to support the growth in trips by bicycle, municipalities must be able to assure cyclists of infrastructure that is:

- Safe – without surface defects that may unnecessarily slow cyclists or cause them to lose control;
- Comfortable – with a smooth riding surface, preferably providing good skid resistance. The riding quality of off-road facilities should be at least as good as that of an adjacent road; and
- Aesthetically acceptable.

From the municipality’s perspective, bike facilities should fulfil all legal requirements and mitigate liability risks, as well as being durable and easy to maintain.

When scheduling their maintenance operations, municipalities should prioritize ‘spines’: long, primary routes that have high connectivity with other facilities. These should benefit from year-round cleaning and snow removal, as should Active Transportation paths that form key connections or links.

Further information regarding maintenance strategies may be found in **Section 8**.

3. Bicycle Facility Type Selection

3.1 General

This chapter provides a detailed explanation of the three step bicycle facility selection process that is recommended for use by bicycle facility designers and practitioners.

This facility selection process provides a consistent framework that is straightforward to apply and uses readily available data. It was developed based on current research and knowledge of facility type selection and best practices regarding 'degrees of separation' as outlined in **Section 3.2.1**.

The tool is not prescriptive. This is to allow flexibility during the decision making process to account for differences in the physical and operational characteristics of the roadway of interest. This is especially true when there are constraints in retrofitting existing corridors and intersections.

However, before a practitioner selects a bicycle facility type, it is important that the following realities are clearly understood:

1. **The choice to separate is not simple:** The choice to provide a separated versus non-separated bicycle facility is not a simple "yes" or "no" decision;
2. **Design criteria need to recognize context:** The design criteria and associated thresholds used to select one bicycle facility type over another need to be flexible to accommodate site specific characteristics; and

3. **The final decision requires professional judgement:** The experience and judgement of a qualified engineering designer or practitioner should ultimately influence the bicycle facility type, plus the added design features or enhancements that are selected.

Research shows that one of the most effective measures for improving overall cyclist safety within a road network is increasing the number of cyclists using the system. However, in order to encourage cyclists of different ages and abilities, a variety of bicycle facilities with different degrees of separation between motorists and cyclists must be available. Separation of cyclists and motor vehicles becomes increasingly more important as traffic volumes and operating speeds increase.

Bicycle facilities exhibit various levels of separation between cyclists and motorists. These range from shared travel lanes with no separation but with the option to provide sharrow markings, to bicycle lanes delineated by pavement markings, to separated bicycle lanes with a painted buffer or physical barrier. Other alternatives are in-boulevard bicycle facilities within the highway right-of-way, or off-road bicycle facilities outside the highway right-of-way. However, a direct comparison of the relative safety of different types of bicycle facilities and degrees of separation is difficult. A bicycle facility with greater separation may appear to be 'safer' but may result in more conflicts at intersections and driveways, especially if the separation makes the cyclist less visible to the motorist. As previously stated, the choice to provide a separated or non-separated bicycle facility is not a simple decision. Designers must critically evaluate the situation by using their engineering experience and professional judgement to make the final facility type selection.

3.2 Overview of the Bicycle Facility Type Selection Process

3.2.1 Suitable Application Environments

The bicycle facility type selection process has been developed for application in both urban and rural environments. However, when going through the process outlined in **Section 3.2.2**, designers must be aware of the fact that urban and rural roadways have different characteristics which need to be considered when selecting a bicycle facility type. For example, on-street parking or frequency of driveways and intersections may be more of a concern in urban situations, while the availability of paved shoulders and level of bicycle use may be more of a concern in rural situations. The following section provides a detailed explanation of the bicycle facility type selection process.

3.2.2 The Process

The bicycle facility type selection process has three steps, as shown in **Figure 3.1**. It is important that practitioners complete each step to ensure that they

have selected the best possible solution given site specific characteristics and available information.

Figure 3.2 provides a model “worksheet” that practitioners can use to guide them through the bicycle facility selection process.

Step 1 allows practitioners to pre-select the desirable bicycle facility type based on the motor vehicle operating speed and the average daily traffic volume. This step is accomplished through the use of the ‘Desirable Bicycle Facility Pre-Selection Nomograph’ illustrated in **Figure 3.3**.

Step 2 guides practitioners to take a more detailed look at site specific characteristics in order to determine the appropriateness of the pre-selected facility type. Practitioners use this step to critically evaluate the situation in order to select the most appropriate facility type.

Step 3 guides practitioners in documenting their rationale for their final decision. **Sections 3.2.2.1** to **3.2.2.3** provide more detailed information about each step.

Figure 3.1 – Bicycle Facility Type Selection 3-Step Process Flow Chart

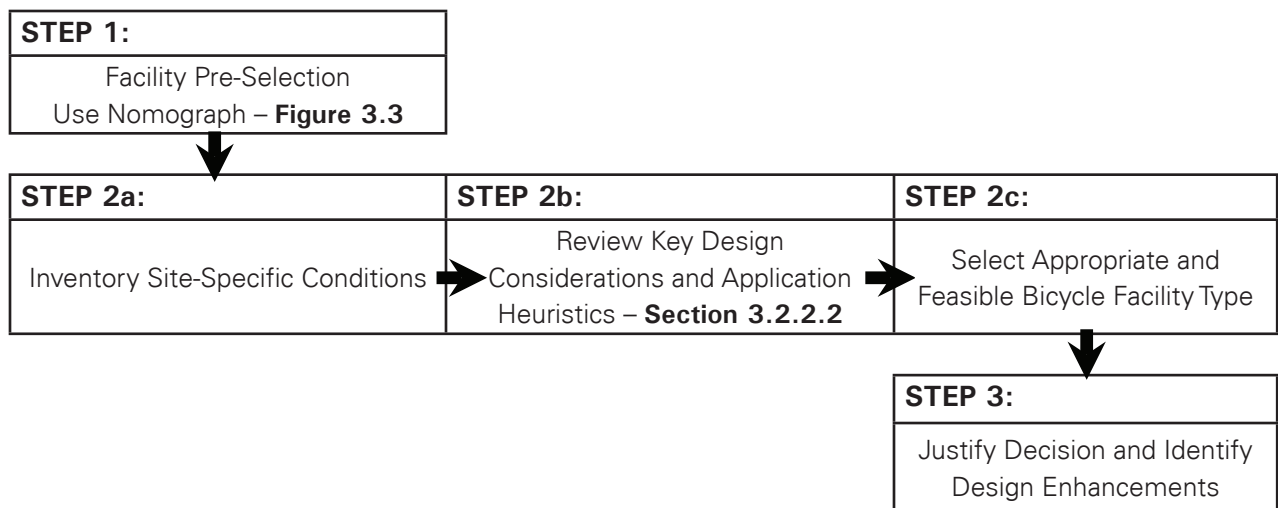

Figure 3.2 – Model Worksheet for the Facility Type Selection Tool

Step One

Pre-select a desirable facility type

Roadway and Section:

STEP 1 of 3
Desirable Cycling Facility Pre-selection Nomograph

Traffic Volume:

Date and source:

Motor vehicle operating speed:

Date and source:

Nomograph Result:

Step Two

A more detailed look

Photo

This view shows the following relevant factors:

Describe Your Site:
Use the Tables in Chapter 3 to describe your site:

- Volume
- Speed
- Sightlines
- Cyclist demand
- Vehicle Mix
- Topographic barriers
- Collision history
- Directness/Accessibility
- Available space
- User skill/security/safety
- User delay
- Maintenance conditions
- By-laws/Regulations
- Costs/funding

Examine Context:
From the Tables in Chapter 3 document applicable principles and application heuristics.

Photo

This view shows the following relevant factors:

Photo

This view shows the following relevant factors:

Attach additional sheets if more documentary photos and data are required.

Step Three

Develop your rationale

If Step 1 yields a result different than Step 2 or if Step 1 is inconclusive, prepare a rationale for selecting a preferred option.

List the relevant principles and heuristics:

Document your design considerations to support the rationale.

A public consultative process should be considered depending on the context, particularly where there is a significant cost or impact on road users associated with the proposals.

3.2.2.1 Step 1: Facility Pre-Selection

Facility pre-selection is undertaken through the use of a nomograph which helps practitioners identify the desirable bicycle facility type for a given situation based on the 85th percentile motor vehicle operating speed and average daily traffic volume.

Several international organizations known for their work in bicycle network planning and facility design such as Transport for London, Sustrans (United Kingdom), CROW (Netherlands), Denmark Road Directorate, Australia Roads Traffic Authority, and the New Zealand Land Transport Safety Authority have developed facility selection nomographs to aid practitioners in pre-selecting bicycle facility types. The principles and suggested thresholds in these nomographs are understood to be based on two-lane, two-way roadways. Within the North American context, there are numerous multi-lane roads which serve as important connectors in urban networks. In areas with few or no practical two-lane alternatives, especially in built-up urban areas, these multi-lane roads should be considered as candidates for the implementation of bicycle facilities.

The 'Desirable Bicycle Facility Pre-Selection Nomograph', illustrated in **Figure 3.3**, was derived from international examples and, therefore, is most applicable to two-lane, two-way roadways. The principles, however, are still applicable to multi-lane roadway situations. In these instances, practitioners should consider the operating speed, total combined traffic volume and mix of vehicles travelling on the lanes directly adjacent to the cycling facility since these are believed to have the greatest effect on cyclists.

The 'Desirable Bicycle Facility Pre-Selection Nomograph' is only the first step in the bicycle facility selection process, and should not be used by itself as the justification for facility selection.

As previously stated, this nomograph may be used to assess urban and rural situations. However, designers must be cognizant of the fact that urban and rural roadways have different characteristics which need to be considered when selecting a bicycle facility type.

In urban areas there are typically more frequent conflict points such as driveways, midblock crossings, intersections and on-street parking. These need to be considered when assessing risk exposure in urban environments since they will influence the selection of suitable facility types. In rural and suburban locations, the availability of paved shoulders and level of bicycle use must be considered.

In addition, roadway characteristics may vary along any given route. Therefore, the route should be divided into homogenous sections for analysis and facility selection. If possible, a consistent facility type should be considered along a given route to maintain cyclist and motorist expectations.

The nomograph is divided into three types of operating environment categories:

1. **Shared Roadway** (Blue)
2. **Designated Cycling Operating Space** (White)
3. **Separated Facility or Alternate Routes** (Red)

The '**Shared Roadway**' environment involves relatively low traffic volumes and low to moderate speeds. If motor vehicle operating speed and average daily traffic lands a designer in the blue

area, the types of bicycle facilities that may be suitable include shared roadways and signed bike routes with standard or wide travelled lanes, with or without shared lane markings.

The **'Designated Cycling Operating Space'** environment involves routes with moderate to high speeds combined with low traffic volumes, as well as scenarios where speeds are low and traffic volumes are moderate. If the motor vehicle operating speed and the average daily traffic volume of a route fall in the white area, the types of bicycle facilities that are suitable include paved shoulders or buffered paved shoulders for rural cross-sections. Exclusive bicycle lanes, separated bicycle lanes or raised cycle tracks may be suitable for urban cross-sections.

The **'Separated Facility or Alternate Routes'** environment involves high-speed scenarios, sites with high traffic volumes, and routes where moderate to high speeds coincide with moderate to high traffic volumes. If the motor vehicle operating speed and the average daily traffic volume of a route fall in the red area, alternate parallel corridors more conducive to cycling should be examined where possible. However, practitioners should consider the implications in terms of cyclist access to popular destinations, network connectivity and the spacing of parallel routes. The types of bicycle facilities that might be suitable include a buffered paved shoulder on a rural road, a separated bicycle lane or raised cycle track on an urban road, or a path in a roadway boulevard.

The nomograph does not contain precisely defined lines between the three operating environment categories since there are no absolute thresholds where one particular facility type is preferred over another. However, the gradual transition in colour on the nomograph from blue to white to red

represents the relative increase in risk to cyclists as speeds and volumes on a roadway increase. As one progresses into higher levels of risk, there is a preference to provide the types of bicycle facilities that result in increasing degrees of separation. Once an operating environment and candidate facility type is identified, the practitioner should proceed to Step 2 to complete a more detailed assessment of site-specific conditions.

Figure 3.3 – Desirable Bicycle Facility Pre-Selection Nomograph

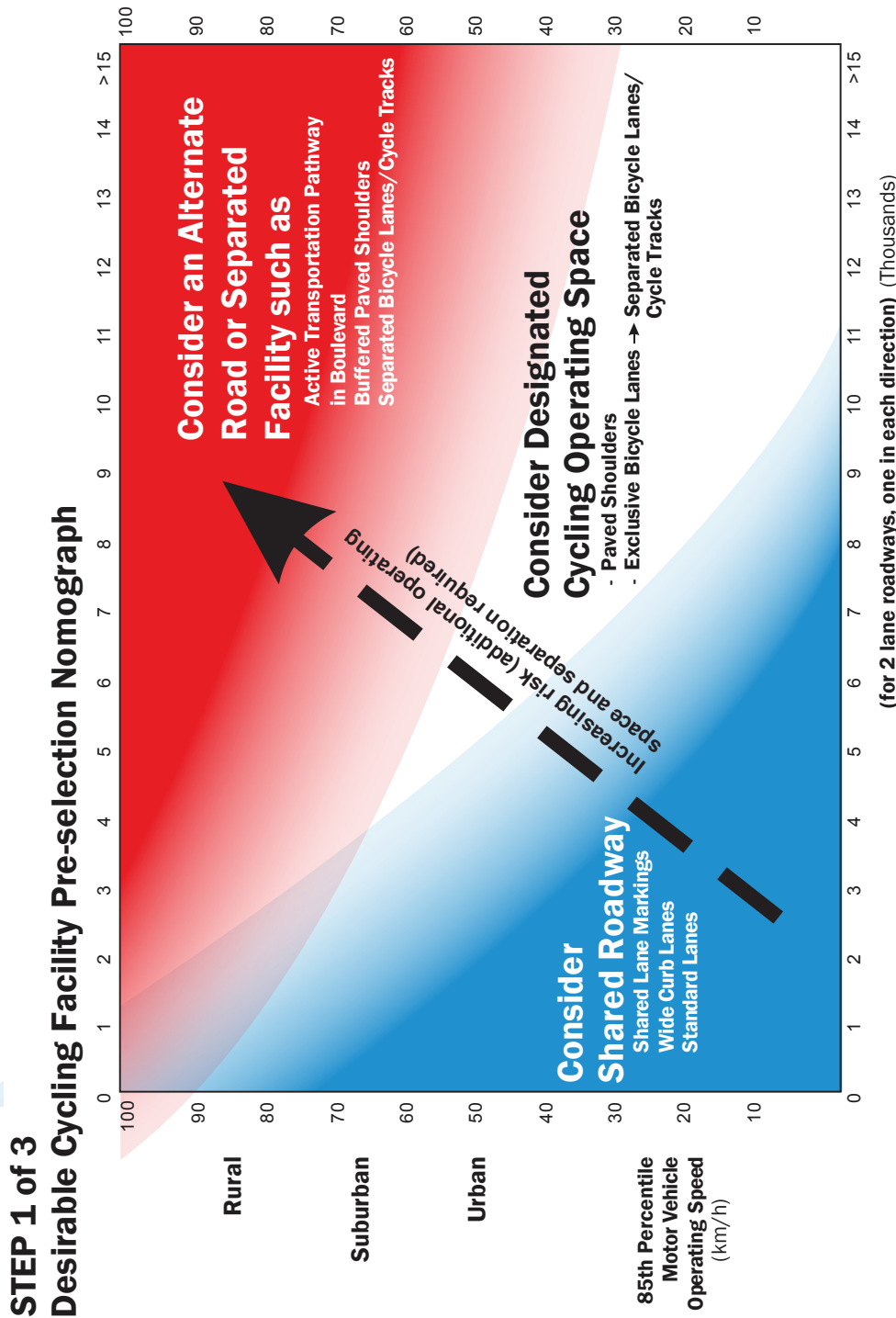

Footnotes: - This nomograph is the first of a three step bicycle facility selection process, and should not be used by itself as the justification for facility selection (see Steps 2 and 3). The nomograph simply helps practitioners pre-select a desirable cycling facility type, however the context of the situation governs the final decision.

- The nomograph has been adapted for the North American context and is based on international examples and research for two lane roadways. It is, however, still applicable for multi-lane roadways. For these situations, designers should consider the operating speed, total combined traffic volume and traffic mix of the vehicles traveling in the lanes immediately adjacent to the cycling facilities.

- Consider a Separated Facility or an Alternate Road for roadways with an AADT greater than 15,000 vehicles and an operating speed of greater than 50 km/h.

- For rural and suburban locations this nomograph assumes good sightlines are provided for all road users. In urban areas, there are typically more frequent conflict points at driveways, midblock crossings and intersections (especially on multi-lane roads), as well as on road segments with on-street parking. This needs to be considered when assessing risk exposure in urban environments since it will influence the selection of a suitable facility type.

Source: MMM, 2013

3.2.2.2 Step 2: A More Detailed Look

A tool such as the nomograph in **Section 3.2.2.1** may aid a practitioner in pre-selecting the desirable bicycle facility type. However, this facility type may not always be the most appropriate solution for a given situation due to other design factors. A set of **application heuristics** or knowledge-based rules, have been developed to aid practitioners in Step 2 of the bicycle facility type selection process. These heuristics link specific site conditions to appropriate facility types and supplementary design features.

Primary determining criteria, not in any specific order, include:

1. 85th percentile motor vehicle operating speeds;

2. Motor vehicle volumes;
3. Function of street, road or highway;
4. Vehicle mix;
5. Collision history; and
6. Available space.

Secondary criteria include:

7. Costs;
8. Anticipated users in terms of skill and trip purpose;
9. Level of bicycle use;
10. Function of route within bicycle facility network;
11. Type of roadway improvement project;
12. On-street parking; and
13. Frequency of intersections.

Tables 3.1 through to **3.13** provide key design considerations for the 13 application heuristics.

Table 3.1 – 85th Percentile Motor Vehicle Operating Speeds

As the speed differential between motorists and cyclists increases, so does the collision risk for cyclists using that roadway. Therefore, when selecting a bicycle facility type, the 85 th percentile operating speed should be considered. Higher motor vehicle speeds may negatively influence a cyclist’s ability to control their bicycle.	
Site Characteristics	Design Considerations and Application Heuristics
Low (30 to 49 km/h)	Speed differential between bicycles and motor vehicles is within 30 km/h, suggesting integration of the two modes as mixed traffic, in standard or wide curb lanes, may be appropriate.
Moderate (50 to 69 km/h)	Exclusive operating space for both bicycles and motor vehicles, in the form of paved shoulders, bicycle lanes or separated facilities is recommended.
High (70 to 89 km/h)	Speed differential between bicycles and motor vehicles exceeds 40 km/h, suggesting physical separation of the two modes is most appropriate such as buffered paved shoulders.
Very high (90 km/h and greater)	Physical separation is preferable, particularly in an urban environment. In rural areas of the province, it may not be practical to provide physically separated facilities on very high speed roadways where bicycles are currently allowed. A painted buffer between the roadway and the paved shoulder is an alternative treatment for such cases. If this is not feasible, provision of a parallel bicycle route should be explored.

Table 3.2 – Motor Vehicle Volumes

As motor vehicle volume increases, so does the collision risk for cyclists using that roadway. For planning purposes, the future year traffic volumes should be used when selecting an appropriate bicycle facility type for a given roadway section. Where AADT volumes are unavailable, rush hour volumes may be used. Some municipalities suggest that as a rule of thumb, rush hour volumes typically represent 10% of the daily volume.

Site Characteristics	Design Considerations and Application Heuristics
Very Low Volume: where two-way daily average volume is less than 500 vpd on a two-lane road	No facility type is typically required.
Low Volume: where two-way daily average volume is 500 to 2,000 vpd on a two-lane road	Mixed traffic may be appropriate if vehicle speeds are low. Lanes should be wide enough to comfortably accommodate shared use by cyclists and motorists. If speeds are moderate, paved shoulders or bicycle lanes should be considered.
Moderate Volume: where two-way daily average volume is 2,000 to 10,000 vpd on a two-lane road	Some level of formal bicycle facility such as a conventional bicycle lane is recommended. If this is not feasible, a signed bicycle route with a paved shoulder may be considered.
High Volume: where two-way daily average volume is greater than 10,000 vpd on a two-lane road	Physical separation of motor vehicle and bicycle traffic may be most appropriate.
Hourly one-way volume in the curb lane exceeds 250 vph	Some level of formal bicycle facility such as a 'signed only' bike route with a paved shoulder or bicycle lanes are recommended.

Table 3.3 – Function of Street or Road or Highway

While generally reflected in motor vehicle volumes, the function of a roadway should also be considered in bicycle facility decisions. The significance of this factor will be higher in cases where volume or speed data are unavailable.

Site Characteristics	Design Considerations and Application Heuristics
Access roads such as local roads and residential streets	Mixed traffic may be appropriate if speeds and volumes are low. Where feasible, design features associated with Bicycle Priority Streets should be applied, as described in section 5.1 . Otherwise, curb lanes should be wide enough to comfortably accommodate shared use by cyclists and motorists, with dimensions as indicated in Table 4.1 for a Wide Signed Bicycle Route.
Both mobility and access roads such as minor collectors plus similar roads and streets	Some level of formal bicycle facility such as a signed bike route with paved shoulder or bicycle lane is appropriate. A Narrow Signed Bicycle Route may be implemented, with dimensions as indicated in Table 4.1 .
Mobility roads such as arterials and major collectors	Some level of formal bicycle facility such as a bicycle lane or separated facility is appropriate.
Motor vehicle commuter route	Separated bicycle facilities should be considered to minimize conflicts with aggressive drivers on the roadway.

Table 3.4 – Vehicle Mix

<p>Heavy vehicles, such as transport trucks and buses have a greater influence on cyclists than passenger vehicles. This is partly due to the larger difference in mass between cyclists and heavy commercial vehicles, and the increased severity of any resulting collision. Air turbulence generated by these high-sided vehicles also has a more significant impact on the difficulty of controlling a bicycle, which requires both greater skill and more caution on the part of the cyclist than in the presence of passenger vehicles. As the volume of heavy vehicles increases, so too does the desirability of providing buffers or physical separation of cyclists from motorized traffic. Stationary trucks and buses may also interfere with cyclist movements, creating a need for lane changes on the part of cyclists. This increases the interaction with vehicular traffic, and at times may obstruct other drivers' view of the cyclist on the road at inopportune moments.</p>	
Site Characteristics	Design Considerations and Application Heuristics
More than 30 trucks or buses per hour are present in a single curb lane	Separated bicycle facilities may be preferred by many cyclists. If paved shoulders, wide curb lanes or bicycle lanes are considered, additional width should be provided as a buffer.
Bus stops are located along the route	Facilities should be designed to minimize and clearly mark cyclist conflict areas with buses or pedestrians at stop locations. See Section 5.4.2 for more details.

Table 3.5 – Collision History

<p>Where there is evidence of the involvement of cyclists in collisions, historical patterns can sometimes provide valuable indicators of the factors that are present and pose particular challenges for the accommodation of cycling facilities, as well as the mitigating measures that can help resolve them.</p>	
Site Characteristics	Design Considerations and Application Heuristics
Bicycle collisions are relatively frequent along the route	A detailed safety study is recommended. Alternate routes should be considered. Separated facilities may be appropriate to address midblock conflicts. If on-road facilities are considered, the operating and buffer space provided to cyclists should be considered.
Bicycle collisions are relatively frequent at specific locations	Localized design improvements should be considered to address contributing factors at high-collision locations, often near intersection and driveway locations.
Noticeable trends emerge from bicycle collisions	The proposed facility and its design should attempt to address noticeable collision trends. For each facility type, safety countermeasures* can be developed. These can be based on road user behaviour and manoeuvres that resulted in the collision, or specific design and policy objectives.
Conflict areas exist between cyclists and motor vehicles or pedestrians	Facilities and crossings should be designed to minimize conflict between different types of users and the conflict area should be clearly marked.

*For detailed scenario-based information, refer to the Bicycle Countermeasure Selection System in the FHWA's BikeSafe guide.

Table 3.6 – Available Space

<p>The space available to serve all functions and users of a roadway is finite. Consequently, practitioners should consider the constraints imposed by curbs, pinch points and physical barriers when choosing the most appropriate facility for a particular section of roadway. Once the facility type has been selected, the adequacy of sightlines, both at intersections and continuously along a roadway should be considered. Please refer to Section 5.4 for more details.</p>	
Site Characteristics	Design Considerations and Application Heuristics
<p>Sufficient curb-to-curb width exists to adequately accommodate motorists and cyclists.</p>	<p>Redistribute roadway space to accommodate bicycle lanes by narrowing or eliminating parking lanes, narrowing travel lanes, or eliminating unnecessary travel or turn lanes. Where bicycle lanes are not feasible, wide curb lanes may be provided. Please refer to Section 5.2 for guidance on integrating bicycle facilities through road retrofits.</p>
<p>Sufficient curb-to-curb width exists, but pinch points are created where turn lanes are developed at intersections.</p>	<p>There is a higher risk of collisions at intersection compared to other sections of road and less confident cyclists may be deterred by a lack of designated bicycle facilities on the immediate approach to an intersection. Where feasible, localized widening should be undertaken to provide continuous bicycle facilities of constant width entering, through and exiting the intersection. Where this is not possible, bike lanes may be discontinued with appropriate positive guidance or warning measures upstream of the merge point or intersection. Practitioners should carefully and practically consider the way in which cyclists and general traffic will merge. Pavement markings and signage should encourage cooperative merging of cyclists and motorists into a single traffic lane. Sharrow markings can be used to denote a desirable cyclist path, particularly through narrow or atypical intersections. Refer to Section 4.2.1.4 for design recommendations.</p>
<p>Physical barriers include those created by steep grades, rivers, freeways, railways, narrow bridges.</p>	<p>Separated facilities should be considered to bypass or overcome barriers.</p>
<p>Curb-to-curb width is not adequate to provide sufficient operating space for both motorists and cyclists.</p>	<p>Provide separated facilities adjacent to the roadway or within an independent right-of-way, provide paved shoulders, widen roadway platform to accommodate bicycle lanes. Where this is not feasible, wide curb lanes may be considered or alternate routes may be investigated. If on-street parking is present, explore opportunities for it to be eliminated or reduced.</p>
<p>Adequate sightlines for road users including both motorists and cyclists on rural roads given design and operating speeds.</p>	<p>Horizontal and vertical curves along the roadway as well as roadway width should be considered when providing adequate sightlines for road users. Regular maintenance of vegetation is also important in preserving sightlines throughout the year.</p>
<p>Sight distance is limited at intersections, crossing locations or where cyclists and motor vehicles share limited road space.</p>	<p>Improve sightlines by improving roadway geometry, removing or relocating roadside furniture and vegetation; provide adequate space for cyclists either on or off the roadway. Design intersection crossings to minimize and clearly mark conflicts, and restrict parking in close proximity to intersections.</p>

Table 3.7 – Costs

<p>In reality, provisions for cyclists on roadway projects will be affected by the availability of funding. Designers should seek to ensure that their solutions are cost-effective, meet project objectives and are appropriate for the intended users given the characteristics of the site. However, cost should not eliminate the need for due diligence in providing safe and effective cycling facilities that encourage use.</p>	
Site Characteristics	Design Considerations and Application Heuristics
More than one type of bicycle facility appears appropriate	Benefit/cost analysis of alternatives should be conducted.*
Funding levels are not available to provide preferred type of facility	Consider alternate routes or focus on cost-effective improvements to existing facilities such as improved maintenance, pavement and drainage rehabilitation as well as removal of barriers. Poorly designed or constructed facilities may result in increased safety risks for cyclists, and are unlikely to encourage additional use.

*Refer to NCHRP Report 552 - Guidelines for Analysis of Investments in Bicycle Facilities.

Table 3.8 – Anticipated Users in Terms of Skill and Trip Purpose

<p>It is important to consider different user skill levels and trip purposes in the design of bicycle facilities. Therefore, providing a variety of facility types, whose distinguishing feature is the presence of different degrees of separation between motorists and cyclists, helps encourage new or less experienced cyclists. This in turn improves overall cyclist safety within a road network. Research shows that one of the most effective measures for doing this is increasing the number of cyclists using the system. The appropriateness of the existing provision on a particular link can be assessed by undertaking cyclist counts. In addition to recording the number of cyclists, the hourly and daily profile will give an indication as to trip purpose; for example, peaks in use during weekday periods demonstrate commuter demand whereas high volumes on the weekend suggests recreational use.</p>	
Site Characteristics	Design Considerations and Application Heuristics
Experienced cyclists (commuter or other utilitarian)	This group generally prefers direct, continuous facilities with minimal delay as is generally provided by the arterial road network. Experienced cyclists may be comfortable on shared use roadways with low motor vehicle volumes and speeds. However, users in this group typically prefer on-street bike lanes or separated facilities where the context warrants it.
Novice cyclists (recreational / beginner utilitarian)	This group generally prefers routes on residential streets with light traffic and low speeds. Bicycle lanes, paved shoulders (with or without buffers) and separated facilities should be considered.
Child cyclists	This group generally requires separated facilities free of conflicts with motor vehicle traffic. Separated facilities should be considered near schools, parks and neighbourhoods. Children under the age of 11 should be permitted to cycle on sidewalks since they may not have the cognitive ability or experience to ride on roads with motor vehicles by themselves.

Table 3.9 – Level of Bicycle Use

<p>As cyclist volumes increase, so does the risk of interactions with motor vehicles. Therefore, as cyclist volume increases, practitioners should consider increased separation between motorists and cyclists.</p>	
Site Characteristics	Design Considerations and Application Heuristics
<p>Low bicycle volumes (< 10 cyclists per hour)</p>	<p>Wide curb lanes may be adequate in some cases. However, practitioners should carefully consider whether the low bicycle volumes represent a lack of cyclist demand or inadequate existing facilities. As improvements are made to cycling infrastructure, bicycle volumes tend to increase.</p>
<p>High bicycle volumes (> 50 cyclists per hour)</p>	<p>Paved shoulders, bicycle lanes or separated facilities may be appropriate. The width provided for urban bicycle facilities should accommodate bicycle volumes during peak periods both midblock and at intersections.</p>
<p>Significant bicycle traffic generators are nearby</p>	<p>Latent bicycle demand may exist if there are employment centres, neighbourhoods, schools, parks, recreational or shopping facilities along the route. Transit nodes also provide the opportunity for multi-modal travel, with bicycle trips to and from the node where appropriate end-of-trip facilities are provided (see Section 7). Bicycle lanes and separated facilities should be considered to accommodate the anticipated volume of cyclists.</p>

Table 3.10 – Function of Route within the Bicycle Facility Network

<p>The function of the route within the bicycle facility network is very important. Bicycle facilities depend on accessibility and connections between routes, major destinations, residential areas and recreational services. Route segments should be identified as primary or secondary routes, and ease of access to and from such facilities should be a major planning and design consideration.</p>	
Site Characteristics	Design Considerations and Application Heuristics
<p>Parallel bicycle routes already exist with bicycle facilities present</p>	<p>Redundancy of bicycle routes may provide an opportunity to provide different types of bicycle facilities within the same travel corridor. This would give cyclists with different skill levels and trip purposes the opportunity to choose the facility most appropriate to their needs.</p>
<p>New route provides a connection between adjacent existing facilities</p>	<p>Facility selection should provide continuity with adjacent bicycle facilities to the extent possible.</p>
<p>New route provides access to a neighbourhood, suburb or other locality.</p>	<p>Bicycle lanes and separated facilities should be considered to encourage cycling for all users.</p>

Table 3.11 – Type of Roadway Improvement Project

The type of roadway improvement project can and most often does affect the type of bicycle facility that is appropriate for a given context. For example, retrofitting existing roads and intersections, platform width and other existing constraints will play a role in selecting the appropriate bicycle facility type. Therefore, consideration must be given to the type of roadway improvement project whether it is new construction, reconstruction or a retrofit. Combining works in this way allows bike facilities to be installed while achieving cost efficiencies. However, practitioners should consider the completeness of the resulting bikeway network. The implementation of small sections of disconnected bicycle facilities is unlikely to provide meaningful connections for cyclists since those facilities may suffer from low cycling volumes. Practitioners should consider using some the resources saved through the aforementioned synergies to provide additional links which will properly integrate the new facilities into the network.

Site Characteristics	Design Considerations and Application Heuristics
New construction	Appropriate bicycle facilities should be planned and integrated with the design and construction of new roads and communities.
Reconstruction	Major roadway reconstruction provides an opportunity to improve provisions for cyclists through the redistribution of existing road space (if reconstruction only involves work between the curbs) or increased roadway width or off-road space. Efficiencies where the two projects overlap will reduce the cost of providing context-appropriate bike facilities.
Resurfacing	Affordable solutions may be limited to redistributing existing road space. Fully paved shoulders may be considered along rural arterials or collectors used by cyclists.

Table 3.12 – On-Street Parking (for urban situations)

<p>The presence of on-street parking has a considerable influence on both the safety and comfort of a cyclist using a bicycle facility. In particular, the configuration of on-street parking, its degree of utilization and its separation from the bicycle facility are of concern selecting a bicycle facility type. Sound engineering judgement must be applied in the design of these facilities. The designer must assess the potential for conflict between cyclists and motor vehicles as a result of vehicles entering or leaving parking spaces. The potential severity and number of conflicts will vary based on the volume of cyclists as well as the parking demand and turnover. In each case, the objective should be to avoid or mitigate conflicts to the extent possible, while recognizing parking needs and alternatives.</p>	
Site Characteristics	Design Considerations and Application Heuristics
Parallel on-street parking is not permitted	Opportunities to provide bicycle lanes or, if not feasible, wide curb lanes should be explored and their appropriateness should be evaluated.
Parallel on-street parking is permitted in localized areas along the route	Consistent bicycle lanes may prove difficult to provide since available roadway width is likely to change where parking is provided. Wide curb lanes may be a compromise solution.
Parallel on-street parking is permitted but demand is low	Opportunities to remove, restrict or relocate parking in favour of providing bicycle lanes should be considered.
Parallel on-street parking is permitted but turnover is low	Bicycle lanes may be appropriate. Additional buffer space between bicycle and parking lanes should be provided.
Parallel on-street parking is permitted; turnover and demand is high	Separated bicycle facilities between on-street parking and the edge of the roadway may be most appropriate. Bicycle lanes between vehicle travel lanes and on-street parking are not desirable in this situation. This is due to the frequent occurrence of conflicts between cyclists and vehicles manoeuvring in and out of the parking area. Where separated facilities cannot be accommodated, potential provision for cyclists on alternate routes should be investigated.
Perpendicular or diagonal parking is permitted	On-road facilities are not appropriate unless parking is reconfigured or removed. Alternate routes or opportunities to provide a separated facility should be explored.

Table 3.13 – Frequency of Intersections (for urban situations)

<p>The more intersections and access points along a bicycle route, the more conflict points that are present. Therefore, locations with increased intersection and access density require careful consideration when selecting a bicycle facility type for the area. Sound engineering judgement must be applied to determine the characteristics of a particular site and a corresponding facility design. The designer must assess the potential for conflict between cyclists and motor vehicles as a result of vehicles entering and exiting the road. The potential severity and number of conflicts will vary based on cyclist and vehicle turning movement volumes. In each case, the objective should be to avoid or mitigate conflicts to the extent possible. This may involve the application of conflict pavement markings, as described in Section 4.2.1.4 and 4.2.2.4.</p>	
Site Characteristics	Design Considerations and Application Heuristics
Limited intersection and driveway crossings are present along the route	Separated facilities or bicycle lanes are well suited to routes with few driveways and intersections.
Numerous low volume driveways or unsignalized intersections are encountered	Bicycle lanes may be more appropriate than separated facilities since motorists are more likely to be aware of cyclists on the roadway rather than adjacent to the road. If bicycle lanes are not feasible, wide curb lanes may be provided.
Numerous high volume driveways or unsignalized intersections are present along the route	Separated facilities are generally not preferred in this situation; bicycle lanes may be more appropriate. Crossings should be designed to minimize conflicts; additional positive guidance should be considered to warn cyclists and motorists of conflicts. If bicycle lanes are not feasible, wide curb lanes may be provided.
Major intersections with high speed and traffic volumes are encountered	Consider provision of bicycle lanes, bike boxes, intersection and conflict zone markings as well as special bicycle signal phases at major intersections. Consider indirect left-turn treatments if there is significant bicycle left turn demand conflicting with through motor vehicle traffic. If a separated facility is being considered, crossings should have bicycle traffic signals with exclusive phases, and conflicts should be clearly marked.

3.2.2.3 Step 3: Justify Your Rationale

Step 3 provides a consistent means of documenting and defending the bicycle facility type selected. Once site conditions have been investigated and the appropriate application heuristics from Step 2 have been examined and documented, the compatibility of the bicycle facility identified in Step 1 with the heuristics identified in Step 2 should be determined. If the site conditions from Step 2 do not support the result of Step 1, then attention should be given to another facility type that may be more compatible with site conditions. Once all factors are considered, it is possible to

make a final decision regarding the appropriateness of the facility type for the specific roadway section being considered. At this point additional design features or enhancements should be considered in the design phase.

It is imperative that the practitioner document each decision made during the bicycle facility type selection process. The steps taken to reach each decision and the rationale behind the selection should be documented. This will assist the designer should they be required to defend any compromises they may have chosen for operational, cost or other reasons based on their engineering judgement.

4. Bicycle Facility Design

This section provides practitioners with guidance related to the design of on-road and in-boulevard bicycle facilities. This includes general geometric considerations, appropriate signage and pavement markings as well as intersection treatments. The detailed design of a bicycle facility should occur after the bikeway network has been planned and the appropriate facility types have been selected. Practitioners should refer to **Section 2** for guidance on bikeway network planning, and **Section 3** which relates to the selection of the appropriate bicycle facility type.

Section 4 has been organized by facility type in order to provide practitioners with easy reference to the tools required for the design of a specific bicycle facility type.

Section 4.1 Shared Roadways includes information for the design of shared roadways and signed bicycle routes as well as signed routes with paved shoulders.

Section 4.2 Bicycle Lanes relates to the design of conventional bicycle lanes on roadways with and without on-street parking, plus separated bicycle lanes.

Section 4.3 Raised Cycle Tracks gives guidance on the design of one-way and two-way raised cycle tracks.

Section 4.4 In-Boulevard Bicycle Facilities is about the design of one-way and two-way in-boulevard bicycle facilities where the bicycle path is distinct from the sidewalk. It also covers shared-use in-boulevard facilities where a single path is provided for both cyclists and pedestrians.

Throughout this section, the design domain is presented as a 'desired width' and 'suggested minimum' guideline. This design domain is intended to provide the practitioner with flexibility when designing bicycle facilities. It is recommended that practitioners design to the desired width. However, it is recognized that in retrofit situations and along constrained corridors, this may not be consistently achievable. Based on their engineering judgement, practitioners may choose to design beyond the desired width guideline where sufficient right-of-way is available or traffic conditions warrant this treatment.

As with the Bicycle Facility Type Selection process outlined in **Section 3**, designers are strongly encouraged to document their rationale. This is particularly important where proposals deviate from desired widths which are considered optimal from a safety perspective. This will assist the designer should they be required to defend any compromises they may have chosen for operational, cost or other reasons.

The design of bicycle facilities will evolve and new ideas will emerge over time. If an engineering review supports an innovative or alternative design solution that differs from the best practice guidelines in Book 18, it is recommended that a municipality consider it as a pilot project and monitor it following implementation.

Refer to **Section 5 – Additional Bicycle Facility Design Applications** for information about additional design considerations such as bicycle priority streets, traffic calming and integrating bicycle facilities as part of road retrofitting projects, as well as designing bicycle facilities at roundabouts, interchanges, ramp crossings, conflict zones, bicycle signals, bridge structures and railway crossings.

4.1 Shared Roadways

4.1.1 Shared Roadways and Signed Bicycle Routes

Unless cycling is specifically restricted, all roadways are considered to be Shared Roadways even if there is no signage present. However, if the shared roadway is designated as part of a bikeway network, the route should be signed using a bicycle route marker M511 (OTM) shown in **Figure 4.3**, or equivalent as described in **section 4.1.1.2**, and is considered a Signed Bicycle Route.

There are many High Occupancy Vehicle (HOV) and reserved transit lanes where cyclists are permitted. Where new reserved lanes are implemented, cyclists should be allowed to use them where appropriate. This should be reflected in the relevant signage and by-laws.

Prior to initiating design work on a given link, practitioners should refer to the Bicycle Facility Type Selection process in **Section 3.2.2**. This will confirm whether a shared roadway and signed bicycle route is the most suitable facility type and identify key design considerations.

4.1.1.1 Geometry

Signed Bicycle Routes are typically implemented on low volume, local and collector streets. Generally, there are no other provisions needed beyond signing. On wide signed bicycle routes, cyclists are expected to ride on the right of the shared travel lane in accordance with the Highway Traffic Act. However, cyclists may position themselves in the centre of a travel lane that is too narrow for motor vehicles to overtake them safely within the lane.

Practitioners may choose to add an optional 'Sharrow' or 'Shared Use Lane Marking' placed on the pavement surface at regular intervals along signed bicycle routes. The sharrow symbol is intended to alert motorists of the expectation to share the lane with cyclists, and to guide cyclists to where they should ride within the shared travel lane. The lateral location of the sharrow within the travel lane depends on the width of the shared lane and whether or not the roadway has on-street parking. The typical placement of the sharrow is discussed in **Section 4.1.1.3**.

Table 4.1 presents the lane width design domain for Shared Roadways and Signed Bicycle Routes. **Figure 4.1** illustrates examples and **Figure 4.2** depicts cross-sections for shared roadways and signed bicycle routes.

Table 4.1 – Desired and Suggested Minimum Lane Widths for Urban Shared Roadways / Signed Bicycle Routes^a

Facility	Desired Width	Suggested Minimum Width
Wide Shared Roadway / Signed Bicycle Route ^a	4.5 m ^b	4.0 m ^c
Narrow Shared Roadway / Signed Bicycle Route ^a	4.0 m	3.0 m ^{de}

^aApplies to curbside lane. Widths for the shared travel lane should be considered from the face of the curb (for urban cross-sections without on-street parking), or the edge of the parking lane (for roads with on-street parking).

^bDue to local variations in width, this may be up to 5.0m in places. However, the lane width should not consistently exceed 4.5m or motorists may attempt to overtake other motorists, causing a safety risk for cyclists. In these cases, provision of a designated bike lane should be considered.

^cOnly suitable for lanes without sharrows or where the designer considers traffic volumes to be low and the speed differential between motor vehicles and bicycles to be minimal. Otherwise, a minimum lane width of 4.3m is suggested.

^dApplied for low volume and low speed conditions; cyclists may take the lane.

^eIt is recognized that travel lane widths may be less than 3.0m – cyclists are still permitted as a vehicle under the HTA to use these roads.

Source: Based on information from MTO Bikeways Planning and Design Guidelines, 1996; AASHTO Guide for the Planning, Design and Operation of Bicycle Facilities, 2012

Figure 4.1 – Examples of Shared Roadways and Signed Bicycle Routes



Figure 4.2 – Cross-Sections of Shared Roadways and Signed Bicycle Routes

(See Table 4.1 for more details)

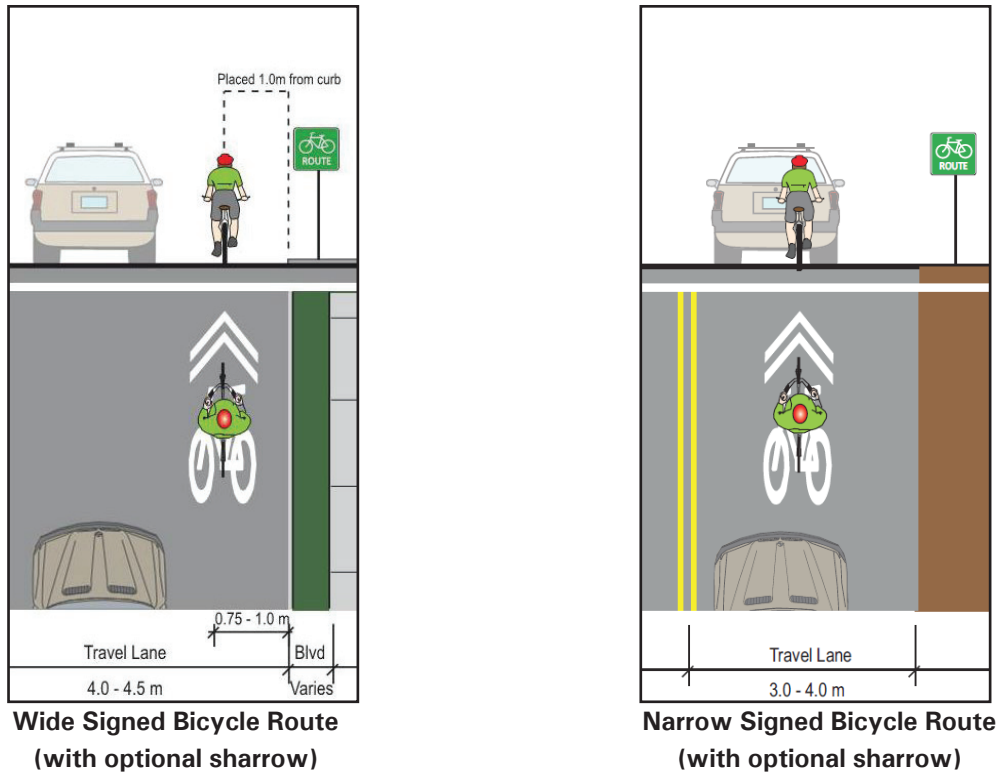

Source: MMM, 2013

4.1.1.2 Signs

All signs used for shared roadways and signed bicycle routes should be sized appropriately for interpretation by both motorists and cyclists, and should conform to the TAC *Bikeway Traffic Control Guidelines for Canada – 2nd Edition* (January 2012).

Bicycle Route Marker Sign

The Bicycle Route Marker sign M511 (OTM), illustrated in **Figure 4.3**, should be used on segments of a shared roadway that are designated as a bicycle route within a bikeway network. Green is the standard colour for standard bicycle route signs; however, alternative sign designs and colours

to brand a trail or bike route can be implemented by a municipality or partner organization. The frequency of the signs should be determined through engineering judgement based on the speed of bicycles and other traffic, as well the distances between intersections, such that the signs guide cyclists and inform them of any designated route changes. Typical sign frequency on a rural roadway is at least one every 2.0 kilometres. On an urban roadway in a built up area, the suggested sign frequency is at least one every 400 to 800 metres. This sign should be also located on the far side of major intersections and other major decision points to assist in wayfinding.

Figure 4.3 – Bicycle Route Marker Sign

M511 (OTM)
(450 mm x 450 mm)

Additional wayfinding signs may be appropriate to provide directional guidance to cyclists. Practitioners should refer primarily to the Ontario Traffic Manual, or (as a secondary resource) to Section 5.2 in the TAC *Bikeway Traffic Control Guidelines for Canada* for more information.

Share the Road / Shared Use Lane Single File Signs

In addition to a Bicycle Route Marker sign M511 (OTM), a road authority may also install the warning signs depicted in **Figure 4.4** to remind motorists to share the road since a bicycle is defined as a vehicle in the *Highway Traffic Act of Ontario (HTA)*.

The signs also serve to caution all road users on the approach to locations where there may be a change in the road configuration. Examples of this include where a paved shoulder ends or narrows and cyclists using the shoulder will be manoeuvring into the travel lane. Another example is on an approach to an up or down grade or roadway curve. In each case, the signs should be used in addition to the appropriate warning sign for the specific condition. In locations where motorists are discouraged from passing cyclists, for example where lane widths are narrow or there is a steep grade, the 'Shared Use Lane Single File' sign Wc-24 (OTM) and supplementary tab Wc-24t (OTM) should be considered.

If the travel lane width is less than 4.0 metres, motorists approaching a cyclist should wait until there is a safe gap in traffic, either in the opposing or adjacent lane, to then cross the centre of the road or make a lane change to pass the cyclist. Although the cyclist is expected to ride as far to the right of the roadway as practicable, they may take the lane if they consider riding on the far right of the roadway to be unsafe. Roads with lane widths less than 4.0 metres are too narrow to permit side-by-side travel, especially where a vehicle is overtaking a cyclist on a higher speed road.

'Share the Road' and 'Shared Use Lane Single File' signs are also used on roads designated for cycling or where cycling is known to occur in built up urban areas. These include roads with higher traffic volumes, low to moderate speeds (40 to 60 km/h) and frequent intersections or driveways. In these conditions, motorists do not typically have the opportunity to safely cross a directional dividing line to pass a cyclist on a two lane road. As a result, if the travel lane width is 4.0 metres or greater, passing may be possible and application of the 'Share the Road' sign Wc-19 (OTM) and supplementary tab Wc-19t (OTM) should be considered. This may be supplemented with a sharrow marking placed 1.0 metre from the centre of the sharrow marking to the face of the curb, or 1.3 metres from the edge of an on-street parking lane. This configuration is known as a Wide Shared Roadway and is shown in **Figures 4.7 and 4.8**.

If the lane width is less than 4.0 metres, side-by-side travel is not to be encouraged and use of the 'Shared Use Lane Single File' sign Wc-24 (OTM) and supplementary tab Wc-24t (OTM) should be considered. If the optional sharrow marking is also proposed, it should be placed in the centre of the lane to reinforce the single file operating condition. This configuration is known as a Narrow Shared Roadway and is shown in **Figures 4.9 and 4.10**.

The decision by designers to use these signs, either in isolation or with sharrow markings, is context sensitive. Designers may consider implementing permanent or temporary ‘Share the Road’ signage to clarify the application of the markings where appropriate. They are unlikely to be required on roads without a marked directional dividing line where traffic volumes are sufficiently low that motor vehicles can cross the centre of the road to overtake cyclists. The same applies to very low volume streets without parking lanes where cyclists and motorists may have to maneuver around vehicles parked by the curb.

Motor Vehicle Passing Prohibited Sign

The “Motor Vehicle Passing Prohibited” and “Do Not Pass Bicycles” tab signs, shown in **Figure 4.5**, should be used to restrict passing manoeuvres in areas where the passing of cyclists by motorists is hazardous due to limited sight distance or other considerations. The termination of this zone is indicated with the use of the ‘Motor Vehicle Passing Prohibited’ sign with the supplementary ‘Ends’ tab sign.

Figure 4.4 – Share the Road and Shared Use Lane Single File Signs)



Wc-19 (OTM)
(600 mm x 600 mm)



Wc-24 (OTM)
(600 mm x 600 mm)



Wc-19t (OTM)
(300 mm x 600 mm)



Wc-24t (OTM)
(300 mm x 600 mm)

Figure 4.5 – Motor Vehicle Passing Prohibited Signs



Rb-66 (OTM)
(600 mm x 600 mm)



Rb-66t (OTM)
(300 mm x 600 mm)



M204 (OTM)
(300 mm x 600 mm)

4.1.1.3 Pavement Markings

Shared roadways or signed bicycle routes may be marked with a Shared Use Lane Symbol or 'Sharrow' unless a paved shoulder is provided. A sharrow consists of two white chevron markings, with a stroke width of 100 millimetres spaced 100 millimetres apart above a white bicycle marking 1.0 metre wide by 2.0 metres long. **Figure 4.6** illustrates a typical sharrow pavement marking and associated dimensioning.

Sharrows are an optional treatment and context specific. They are used on streets where dedicated bicycle lanes are desirable but are not feasible due to physical or other constraints. The maximum suitable traffic speed is 50 km/h for single file, or 60 km/h for side-by-side travel. Sharrows are also used to guide cyclists, for example around parking and through intersections.

Where sharrows are applied to a shared roadway or signed bicycle route, they should be placed immediately beyond an intersection or transition from a bicycle lane, and prior to an intersection or transition to a bicycle lane. Furthermore, sharrows should be placed at typical intervals of 75 metres to remind road users of the suggested positioning of cyclists in the lane, or with less separation where they are used at transitions or conflict zones.

The lateral placement of the sharrow within the travel lane is described for various applications in **Section 4.1.1.4**. Refer to **Section 4.2.1.4** for typical transition applications where 'Share the Road' and 'Shared Use Lane Single File' signs may be used with sharrow markings in advance of an introduced bicycle lane or after a bicycle lane is discontinued.

Figure 4.6 – 'Sharrow' Pavement Marking

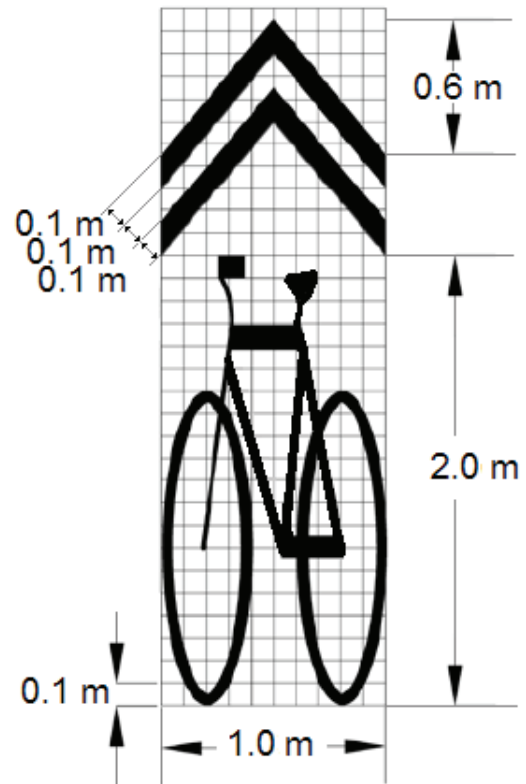

Source: Based on the TAC Bikeway Traffic Control Guidelines for Canada, 2012 (Section 7.4.3, p. 52)

4.1.1.4 Design Applications

Wide Signed Bicycle Route without On-Street Parking

On shared roadways designated as part of a bikeway network, the route should be signed with a green bicycle route marker M511 (OTM). The 'Share the Road' sign Wc-19 (OTM) and corresponding tab sign Wc-19t (OTM) may be installed to supplement the green bicycle route marker. If the practitioner has

decided to include the optional sharrow treatment on a wide signed bicycle route without on-street parking and there are no site constraints, the centre of the sharrow should be placed 1.0 metre from the face of the curb as illustrated in **Figure 4.7**.

Figure 4.7 – Wide Signed Bicycle Route without On-Street Parking

(See Table 4.1 for more details)

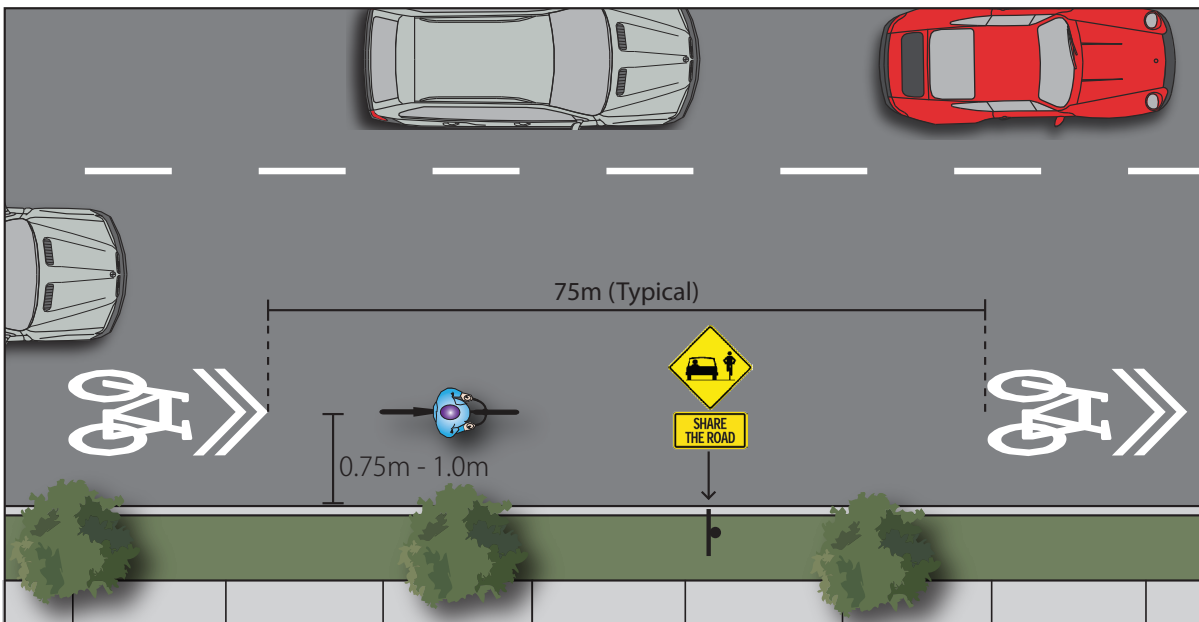

Source: MMM/ALTA, 2013

Wide Shared Roadway / Signed Bicycle Route with On-Street Parking

On shared roadways designated as part of a bikeway network, the route should be signed with a green bicycle route marker M511 (OTM). The 'Share the Road' sign Wc-19 (OTM) and corresponding tab sign Wc-19t (OTM) may be installed to supplement the green bicycle route marker. If the practitioner has decided to include the optional sharrow

treatment on a wide signed bicycle route with full time on-street parking, the centre of the sharrow should be placed at least 1.3 metres from the edge of the parking lane as illustrated in **Figure 4.8**. This directs the cyclist to ride a sufficient distance from parked vehicles to avoid colliding with an opening car door or alighting passenger. If the shared travel lane is less than 4.0 metres wide from the edge of the parking lane, the sharrow should be placed in the centre of the travel lane, as shown in **Figure 4.9**.

Figure 4.8 – Wide Signed Bicycle Route with On-Street Parking

(See Table 4.1 for more details)

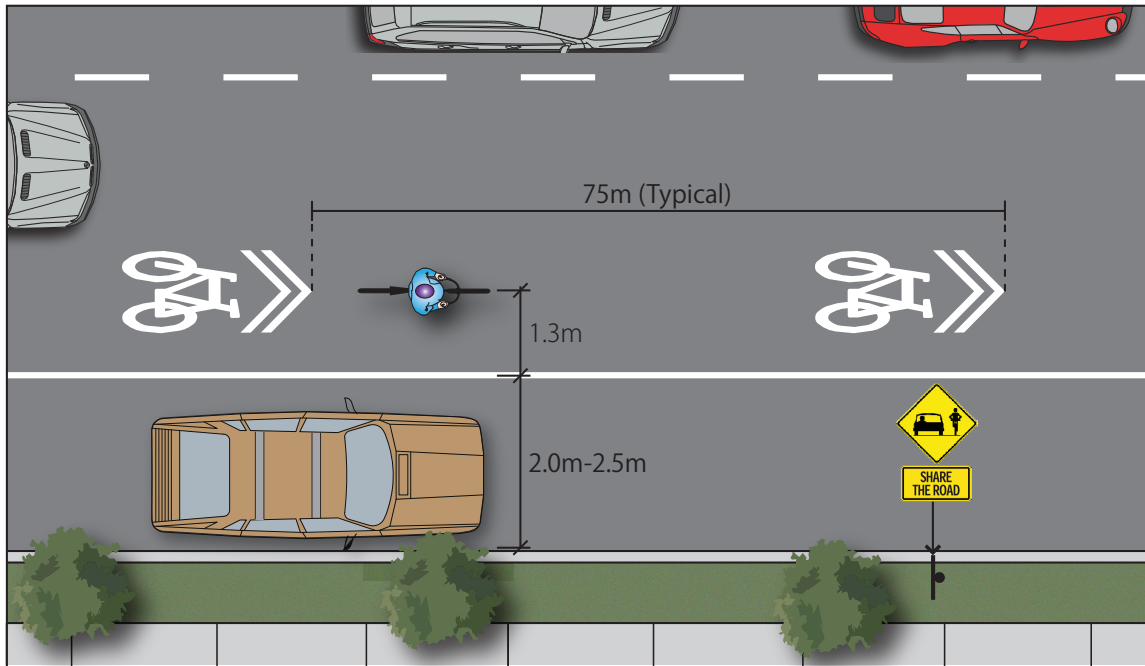

Source: MMM/ALTA, 2013

Figure 4.9 – Narrow Signed Bicycle Route without On-Street Parking

(See Table 4.1 for more details)

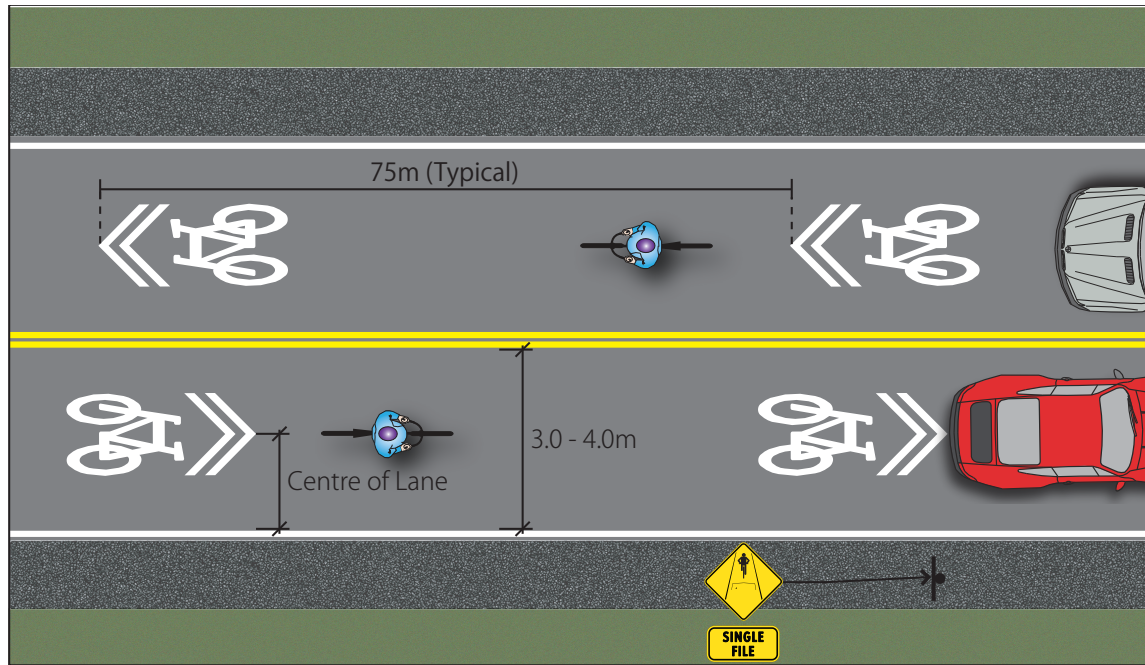

Source: MMM/ALTA, 2013

Narrow Shared Roadway

On shared roadways designated as part of a bikeway network, the route should be signed with a green bicycle route marker M511 (OTM). On roadways where the travel lane is too narrow for motorists to safely pass cyclists in a single lane, motorists and cyclists are encouraged to travel in single file and cyclists are encouraged to use the full lane. The 'Shared Use Lane Single File' sign Wc-24 (OTM) and supplementary tab sign Wc-24t (OTM) should

be installed to indicate this. The posted speeds on these roadways should be 50km/h or less. If the practitioner has decided to include the optional sharrow treatment, the sharrow should be placed in the centre of the travel lane. This is also the case where a parking lane is present, as shown in **Figure 4.10**.

Figure 4.10 – Narrow Signed Bicycle Route with On-Street Parking

(See Table 4.1 for more details)

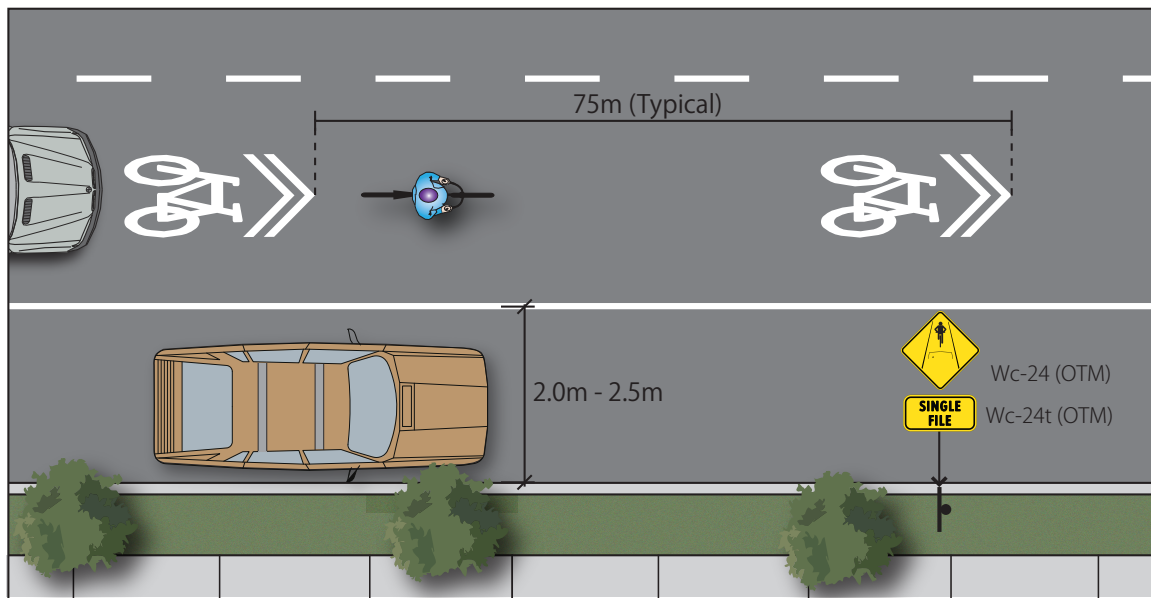

Source: MMM/ALTA, 2013

4.1.2 Signed Bicycle Route with Paved Shoulder

A paved shoulder is a portion of a roadway which is contiguous with the travelled way and provides lateral support for the pavement structure. It accommodates stopped and emergency vehicles, pedestrians and cyclists. It is often used by cyclists for travel since it provides them with an area for riding that is adjacent to but separate from the motor vehicular travel portion of the roadway. Cyclists must travel in the same direction as the motor vehicle traffic immediately adjacent to the paved shoulder.

At the time of publication, it is considered that cycling on paved shoulders along municipal roads is permitted under section 185(2) of the Highway Traffic Act (HTA). If the roadway with a paved shoulder is designated as part of a bikeway network, the roadway should be signed with the green bicycle route marker M511 (OTM).

4.1.2.1 Geometry

Signed bicycle routes with paved shoulders should typically have shoulders between 1.5 and 2.0 metres in width depending on the volume, speed and mix of vehicular traffic. As motor vehicle volumes increase, practitioners may consider wider paved shoulders or a buffered zone, as indicated in **Table 4.2**. However, in situations where the facility type selection process has identified the need for a paved shoulder within a constrained corridor, practitioners may consider providing a minimum paved shoulder width of 1.2 metres after applying good engineering judgement and consideration of the context specific conditions.

Where a signed bicycle route with paved shoulders has a shoulder width of 2.0 metres or wider, the shoulder must include a minimum 0.5 metre wide buffer zone. The buffer zone may consist of a marked

buffer or a rumble strip on rural roads. On roadways where the speed or volume of motor vehicles in the adjacent travel lane is high, the shoulder width and buffer zone may be increased to provide greater separation between motorists and cyclists. Refer to **Section 4.1.2.4** for design information on rumble strips.

Along wide shared roadways with urban cross-sections, practitioners may choose to apply a white edge line to designate an 'urban shoulder'. Cyclists and motorists may interpret this space as a bicycle lane even though no bicycle pavement markings are applied to this area. However, it should be noted that urban shoulders are not an alternative to bicycle lanes but may be used on roadways where there is a strong, site specific justification for not implementing conventional bicycle lanes.

If 2.0 metres in width or greater, the urban shoulder may also act as a space for on-street parking. Consideration should be given to the number of parked vehicles and their impact on the trajectory of cyclists. Because urban shoulders will be used by cyclists, bike friendly features such as side inlet catch basins should be incorporated. Please refer to **Section 5.9.1** for more details.

On rural roads without curbs, practitioners should avoid the creation of edge drop-offs; these occur where the vertical distance between the pavement surface and the adjacent material is too great. Careful attention should be paid to the vertical alignment of the pavement near the edge of the shoulder, particularly when designing or implementing rural paved shoulders. Please refer to **Section 8.2.4** in **Section 8** for more information on the associated safety risks and mitigating measures.

Table 4.2 – Desired and Suggested Minimum Paved Shoulder Widths for Rural Cross-Sections on Signed Bicycle Routes^a

Motor Vehicle AADT ^b	Desired Width ^c	Suggested Minimum Width
701 – 1,500	1.5 m	1.2 m ^d
1,501 – 3,000	1.5 m	1.2 m
3,001 – 4,500	1.5 m	1.2 m
> 4,500	2.0 m ^e	1.2 m

^aThis table provides general guidance for roadways where bicycle volumes are at least 25 per day (existing or expected) or that are on routes recommended in an Active Transportation Plan. Practitioners should consider undertaking more detailed analysis when preparing a bicycle plan or where site specific roadway conditions warrant it.

^bPaved shoulders are not required on rural roads with a motor vehicle AADT of 700 or less.

^cPractitioners should consider providing a buffer (desired width 1.0 m; suggested minimum width 0.5 m) alongside the paved shoulder if rumble strips exist or are proposed, the road experiences truck volumes of at least 30 trucks per hour or sight lines are poor. Additional separation between cyclists and heavy vehicles reduces the aerodynamic impact of passing trucks on cyclist stability.

^dOn very low volume roads, a paved shoulder of any width should be considered. Shoulder widths that are less than the suggested minimum of 1.2m, however, should typically be applied only where sight lines are good and truck volumes are low.

^eWhere a width of 2.0 m or more is available, a paved shoulder of 1.5 m should be provided and the remaining width should be allocated to a buffer.

The images in **Figure 4.11** show examples of paved shoulders. The picture on the right highlights the importance of considering the level of on-street parking and its impact on the effectiveness of the shoulder for cyclists. **Figure 4.12** illustrates cross-sections for a signed bicycle route with paved shoulders.

Figure 4.11 – Examples of Signed Bicycle Routes with Paved Shoulders



Figure 4.12 – Cross-Sections of Signed Bicycle Routes with Paved Shoulder
 (See Table 4.2 for more details)

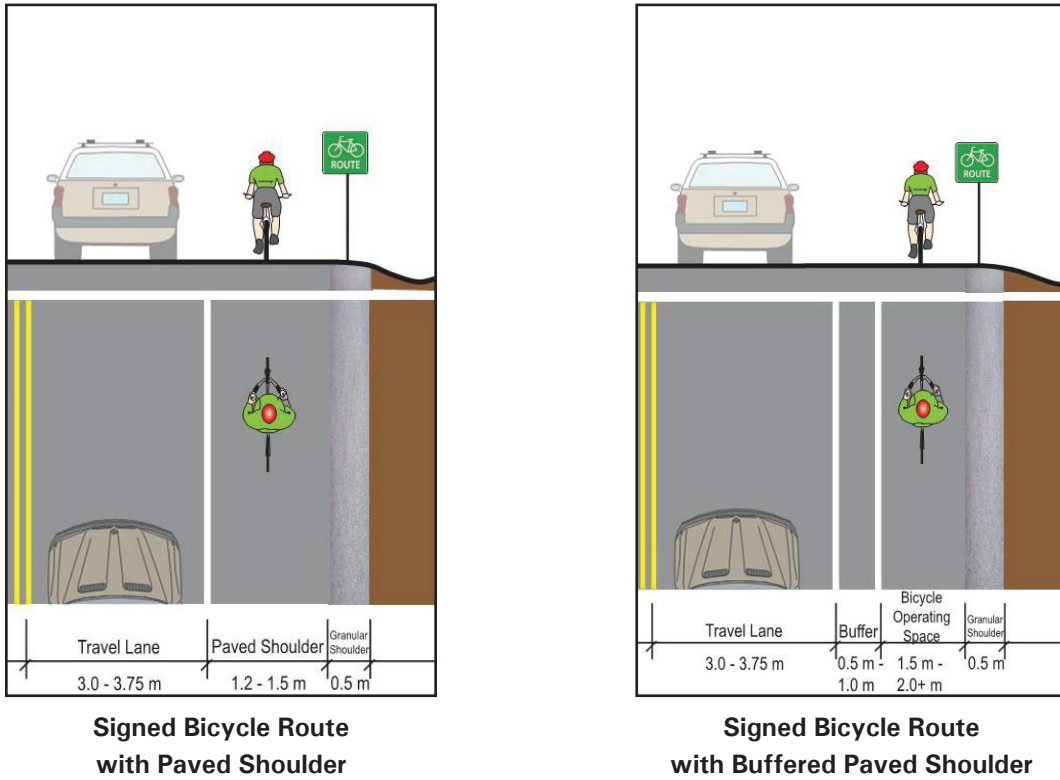

Source: MMM, 2013

4.1.2.2 Signs

All roadways, unless cycling is specifically restricted, are considered to be shared roadways even if there is no signage present. All signs used for shared roadways and signed bicycle routes should be sized appropriately for interpretation by both motorists and cyclists, and should conform to the TAC *Bikeway Traffic Control Guidelines for Canada* – 2nd Edition (January 2012).

Bicycle Route Marker Sign

Figure 4.13 – Bicycle Route Marker Sign



M511 (OTM)
(450 mm x 450 mm)

The Bicycle Route Marker sign M511 (OTM), illustrated in **Figure 4.13**, should be used on segments of a shared roadway that are designated as a bicycle route within a bikeway network. Green is the standard colour for standard bicycle route signs however alternative sign designs and colours to brand a trail or bike route can be implemented by a municipality or partner organization. The frequency of the sign should be determined through engineering judgement based on the speed of bicycles and other traffic, as well the distances between intersections, such that the signs guide cyclists and inform them of any designated route changes. Typical sign frequency on a rural roadway is at least one every 2.0 kilometres. On an urban roadway in a built up area, the suggested sign frequency is at least one every 400 to 800 metres.

This sign should be also located on the far side of major intersections and other major decision points to assist in wayfinding.

4.1.2.3 Pavement Markings

Paved shoulders are delineated using a 100 millimetre wide white edge line, shown in **Figure 4.14**, placed between the travelled portion of the roadway and the paved shoulder.

A buffered paved shoulder is delineated using two 100-millimetre solid white lines spaced 0.5 to 1.5 metres apart with optional diagonal hatching or a ‘skip pattern’ rumble strip between the two edge lines. If the latter is used, it is recommended that the line closest to the paved shoulder follow the same skip pattern to alert cyclists when there is a break in the rumble strip. Alternatively, the buffer may be delineated by a 100-millimetre solid white line, which defines the boundary between the buffer and the paved shoulder, and a solid white line 100 to 200 millimetres wide, which defines the boundary between the buffer and the travel lane, as indicatively shown in **Figures 4.15** and **4.16**. Signed bicycle routes with paved shoulders do not require any other pavement markings.

Refer to **Section 4.1.2.4** for examples of these two design applications of a buffered paved shoulder: with diagonal hatching or with a rumble strip.

Figure 4.14 – Solid White Edge Line



Source: TAC *Bikeway Traffic Control Guidelines for Canada*, 2012 (Table 7-1)

4.1.2.4 Design Applications

Figure 4.15 – Signed Bicycle Route with Paved Shoulders and Marked Buffer

(See Table 4.2 for more details)

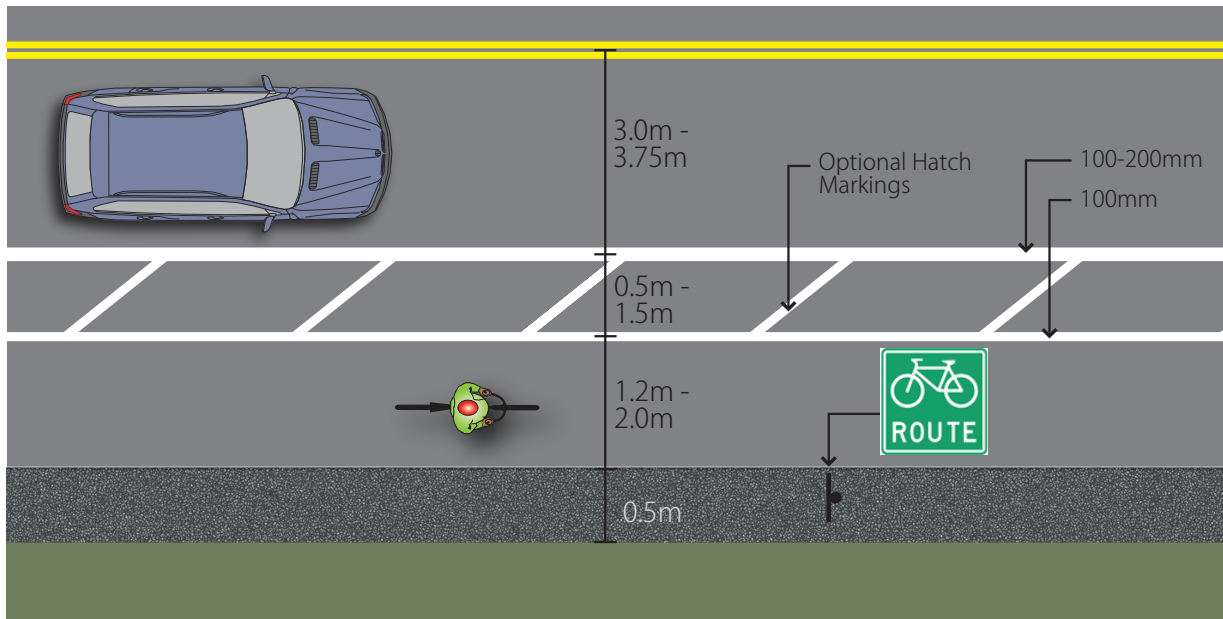

Source: MMM/ALTA, 2013

Figure 4.16 – Signed Bicycle Route with Paved Shoulders and Rumble Strips

(See Table 4.2 for more details)

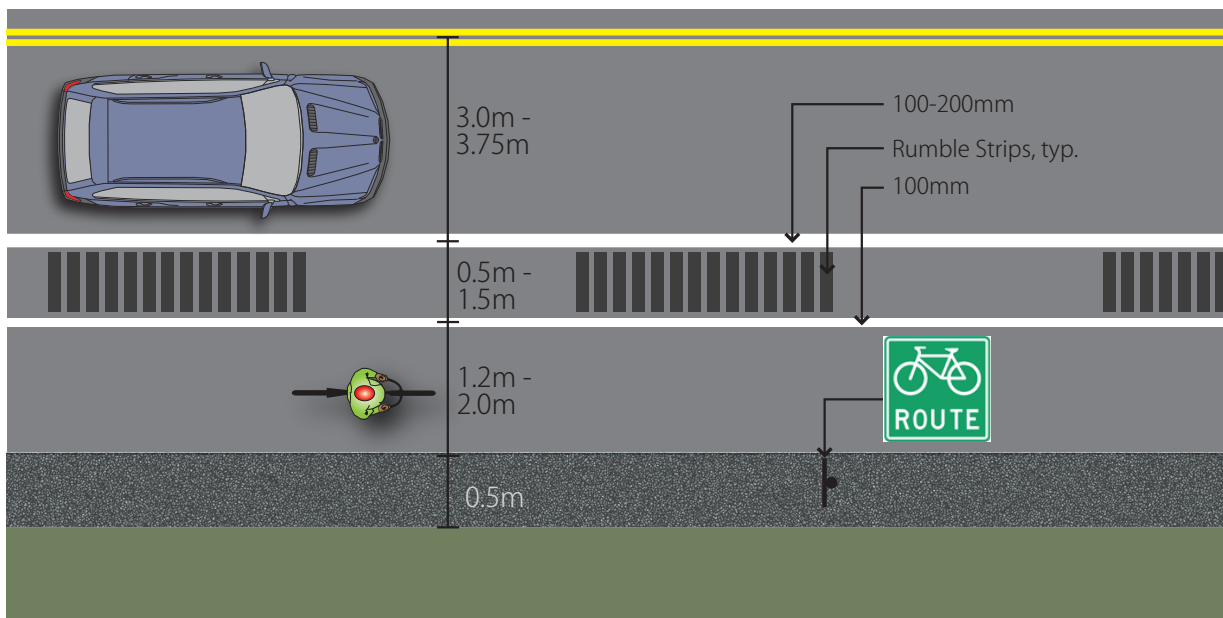

Source: MMM/ALTA, 2013

Design Considerations for Rumble Strips

A **Rumble Strip** is a grooved pattern separating the travelled portion of the roadway from the paved shoulder.

Rumble strips are typically implemented as a road safety measure to benefit motorists. They alert drivers through sound and vibrations to the fact that they are drifting out of the travel lane onto the shoulder. However, from the cyclist's perspective there are safety issues associated with rumble strips on rural roadways designated as bicycle routes.

At best, rumble strips will cause discomfort for cyclists riding over them. At worst, they may compromise a cyclist's control of the bicycle, which is particularly dangerous where cyclists are travelling alongside fast-moving or heavy vehicles. Similarly, by restricting manoeuvrability around obstacles on the paved shoulder, rumble strips may cause cyclists to veer into the travel lane or off the edge of the paved roadway.

If rumble strips are proposed for a road that is designated as a bicycle route, their design should consider that most cyclists will use the paved shoulder. Accordingly, a rumble strip with a skip pattern should be implemented. The skip pattern allows cyclists to manoeuvre in and out of the paved shoulder to pass stopped cars and other cyclists, as well as to avoid debris on the shoulder. Periodic gap lengths of 3.6 m should be provided between each 18.3 m minimum set of shoulder rumble strips to provide cyclists with enough room to exit or enter the paved shoulder without riding over the rumble strip.

If diagonal hatched lines are applied within the buffer, the lines should be 100 mm wide, and placed at an angle of 45 degrees in the direction of travel. The spacing between the diagonal lines is generally a function of vehicular speed. Diagonal lines should be spaced 18 m apart on low to moderate speed roadways, and 36 m on high speed roadways. The frequency of hatching on the far side or near side of an intersection should start at 3 m, and gradually increase to 18 m for low to moderate speed roadways, and 36 m for high speed roadways.

If shoulder rumble strips with a skip pattern are applied within the buffer, then it is recommended that the line which is furthest from the motor vehicle travel lanes should follow the skip pattern to alert cyclists when there is a break in the rumble strip.

The design of the shoulder rumble strips should be consistent with MTOD 503.070 for 0.5 m wide buffers, MTOD 503.080 for 1.0 m wide buffers and MTOD 503.090 for 1.5 m wide buffers. See **Figures 4.17a, b and c** respectively.

Figure 4.17a – Shoulder Rumble Strips for 0.5m Bicycle Buffer Zone (as per MTOD 503.070)

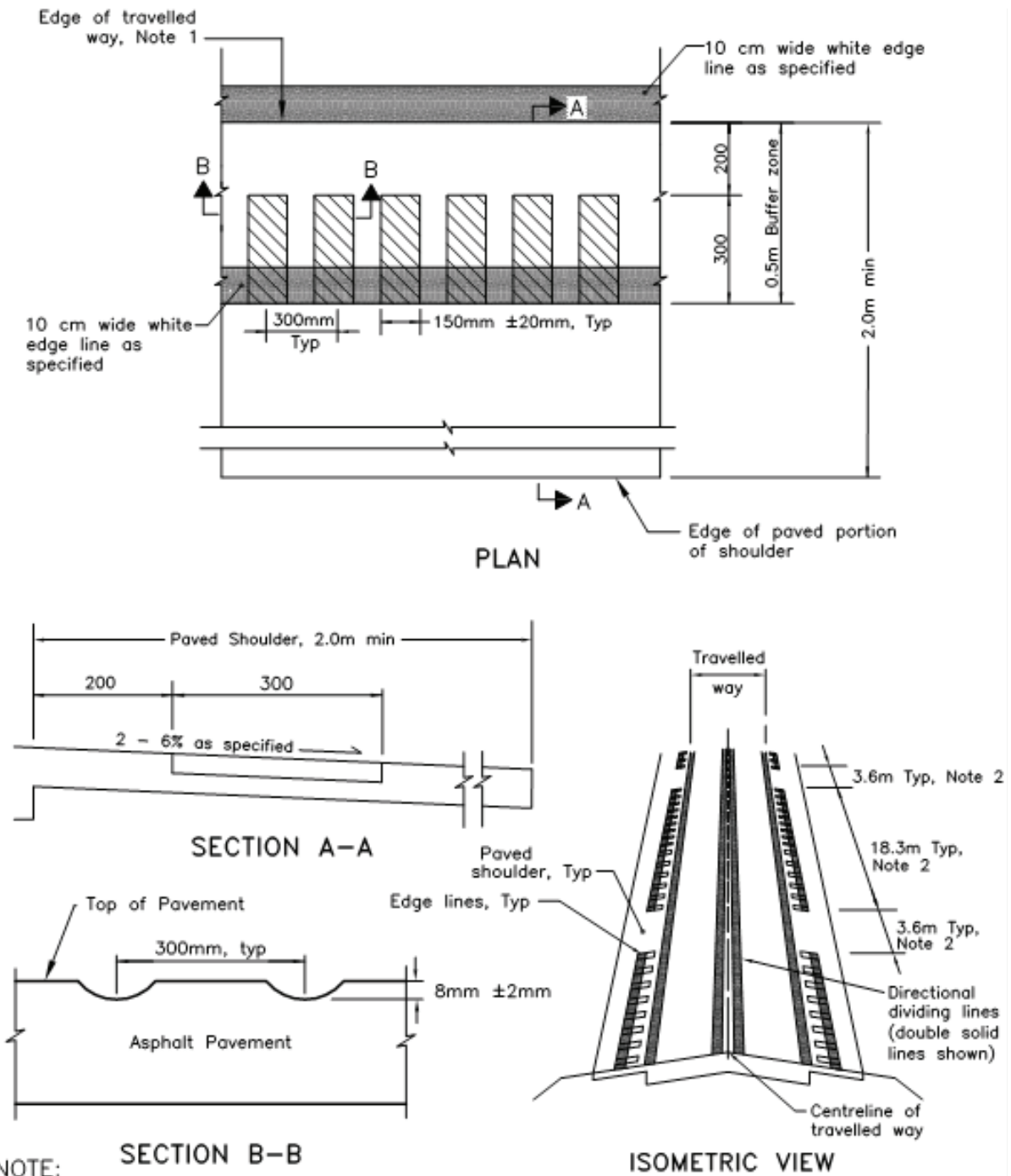

NOTE:

- 1 Where pavement widening on curve treatment provided, edge lines and rumble strips shifted to follow outside edge of pavement widening
- 2 At intersections and entrances, dimensions adjusted in accordance with MTOD503.022

A All dimensions are in millimetres unless otherwise shown.

Source: MTO

Figure 4.17b – Shoulder Rumble Strips for 1.0m Bicycle Buffer Zone (as per MTOD 503.080)

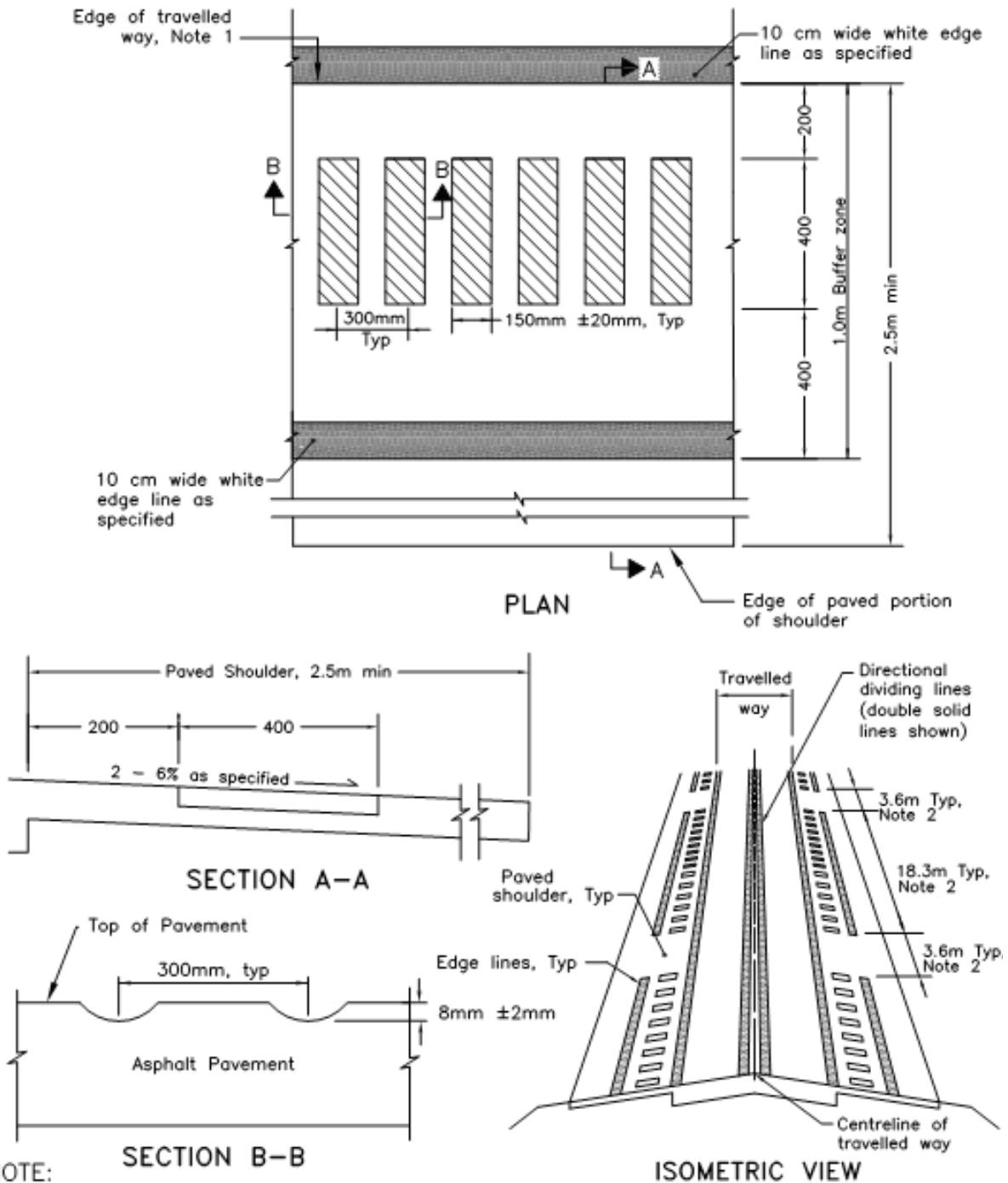

NOTE:

- Where pavement widening on curve treatment provided, edge lines and rumble strips shifted to follow outside edge of pavement widening
- At intersections and entrances, dimensions adjusted in accordance with MTOD 503.022.

A All dimensions are in millimetres unless otherwise shown.

Source: MTO

Figure 4.17c – Shoulder Rumble Strips for 1.5m Bicycle Buffer Zone (as per MTOD 503.090)

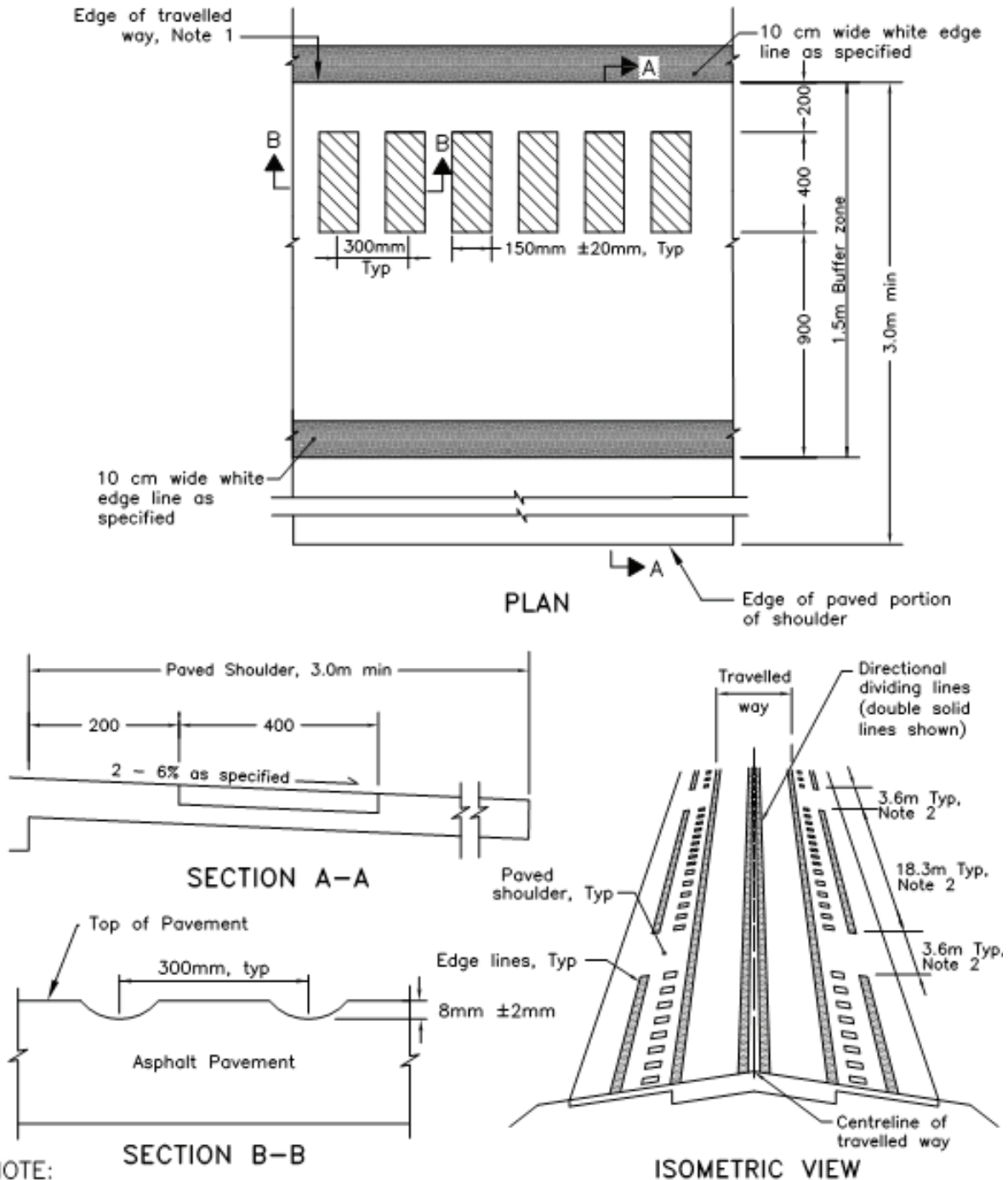

NOTE:

- 1 Where pavement widening on curve treatment provided, edge lines and rumble strips shifted to follow outside edge of pavement widening
- 2 At intersections and entrances, dimensions adjusted in accordance with MTOD 503.022.

A All dimensions are in millimetres unless otherwise shown.

Source: MTO

4.2 Bicycle Lanes

4.2.1 Conventional Bicycle Lanes

A Bicycle Lane is a portion of a roadway which has been designated by pavement markings and signage for preferential or exclusive use by cyclists. Motor vehicles are typically not permitted to enter the bicycle lane except if a dashed line is used, for example at the approach to an intersection permitting motor vehicles to enter the bicycle lane to complete a right turn manoeuvre. Bicycle lanes are typically implemented along urban thoroughfares with higher traffic volumes and operating speeds than local roadways.

Prior to initiating design work on a given link, practitioners should refer to the Bicycle Facility Type Selection process in **Section 3.2.2**. This will confirm whether the conventional bicycle lane is the most suitable facility type and identify key design considerations.

4.2.1.1 Geometry

Curbside conventional bicycle lanes should be 1.8 metres wide, measured to the face of the curb or, in its absence, the edge of the roadway. Practitioners may provide a 2.0 metre facility on roadways with higher bicycle volumes to facilitate overtaking

within the bicycle lane. However, conventional bike lanes are typically no wider than this so that they are not misinterpreted as being for general traffic use. Bicycle lanes should be at least 1.5 metres wide to allow for lateral movement within the lane, and to enable cyclists to avoid debris or pavement defects for example.

In some situations, a painted buffer may be appropriate to protect the cyclist from colliding with or clipping stationary objects. Cyclists will assume that they can safely use the full width of any designated bike facility. Provision of a buffer clarifies where cyclists should ride to minimize their risk. Where there are motor vehicle travel lanes on either side of the bicycle lane, practitioners should provide the maximum 2.0 metre width to give cyclists added protection from moving traffic.

Table 4.3 presents the desired and suggested minimum lane widths for conventional bicycle lanes. It is recommended that practitioners always design to the desired width. However, through the use of sound engineering judgement, a practitioner may consider reducing the width to a value greater than or equal to the suggested minimum, but only for context specific situations on segments or corridors with constrained right-of-way widths.

Table 4.3 – Desired and Suggested Minimum Widths for Bicycle Lanes (to the face of curb)

Facility	Desired Width	Suggested Minimum
Conventional Bicycle Lane ^e	1.8 m ^a	1.5 m ^b
Conventional Bicycle Lane splitting two travel lanes ^c	2.0 m	1.8 m
Conventional Bicycle Lane adjacent to on-street parking	1.5 m lane + 1.0 m buffer	1.5 m lane + 0.5 m ^d buffer
^a Up to 2.0 metres where high volumes of cyclists are anticipated, to facilitate overtaking within the bike lane. ^b In a low volume, low speed constrained corridor with no gutter, this may be reduced to 1.2 metres. Cyclists may have to cross into the adjacent travel lane with little warning to avoid any debris or pavement defects. ^c Includes bike lanes between through lanes and turn lanes on the approach to an intersection. Also applies to bike lanes between through lanes and merge lanes downstream of an intersection. ^d Assumes a parking lane width of 2.5 metres, although where possible the buffer width should be increased by reallocating road space from the parking lane. This is to encourage motorists to park closer to the curb, thus reducing the conflict zone between cyclists and car doors that may open without warning. In a low volume, low speed constrained corridor, a minimum 1.8-metre wide bicycle lane may be provided without a buffer. However, the practitioner should consider the increased risk of collisions between cyclists and opening car doors or alighting passengers. ^e Includes bicycle lanes alongside continuous barriers such as guiderails and underpass walls. Where intermittent obstructions (for example, sign posts) are present alongside the bicycle lane, a width of 1.8 – 2.0 metres is recommended.		

Source: Based on the AASHTO Guide for the Planning, Design and Operation of Bicycle Facilities, 2012

Figure 4.18 illustrates examples of the scenarios shown in **Table 4.3**, and **Figure 4.19** depicts typical cross-sections.

Conventional bicycle lanes located on roadways with on-street parking are typically positioned between the motor vehicle travel lane and the parking lane. However, they may also be located between the parking lane and the curb (discussed in **Section 4.2.2** on Separated Bicycle Lanes). In both situations, practitioners should consider the potential hazard of motor vehicle doors opening into the travelled portion of the bicycle lane and impacting cyclists.

It is recommended that practitioners minimize this risk by providing a 0.5 to 1.0 metre buffer to guide cyclists away from the conflict zone. In this case it is preferable for the bicycle lane to be 1.5 metres wide, with additional available right-of-way being used for the buffer instead of a wider bicycle lane.

It is recognized that the parking lane width may vary between 2.0 and 2.5 metres. However, it is recommended that practitioners design to the minimum parking lane width in order to encourage motorists to park closer to the curb. **Section 4.2.1.4** provides further detail on the design application of bicycle lanes on roadways with on-street parking.

Figure 4.18 – Examples of Conventional Bicycle Lanes

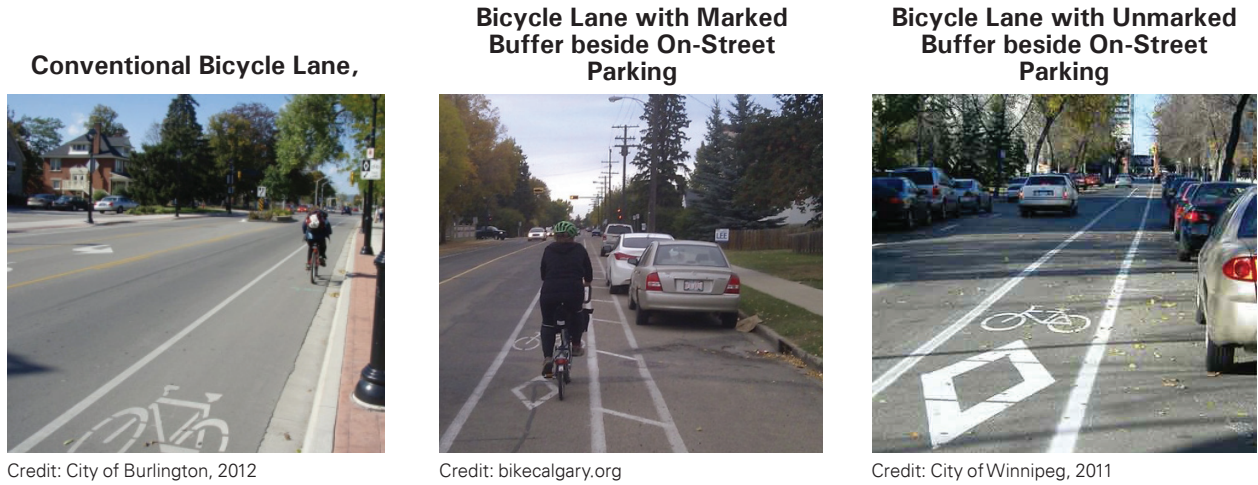
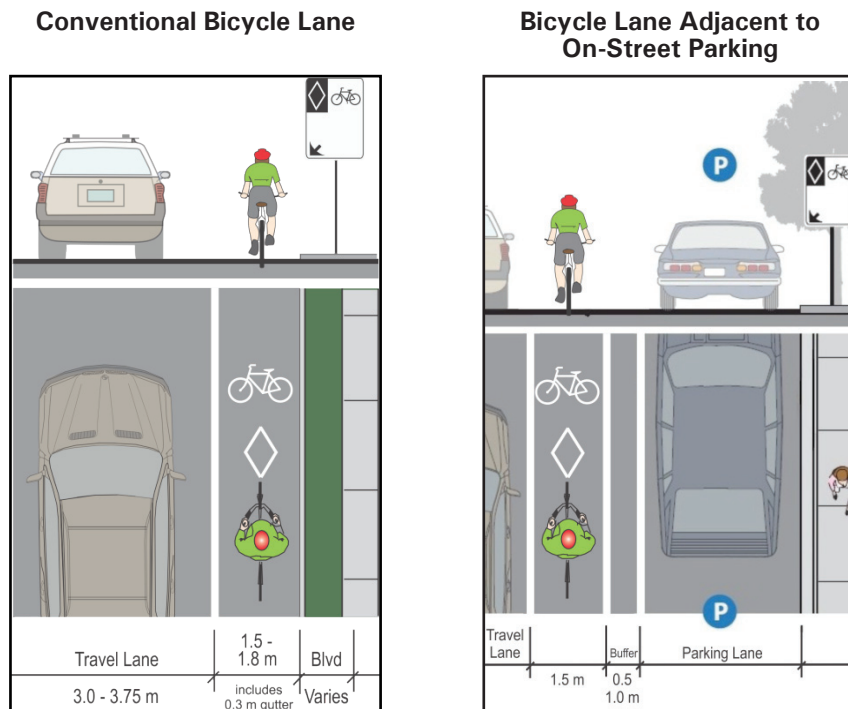

Figure 4.19 – Cross-Sections of Conventional Bicycle Lanes

(See Table 4.3 for more details. As an option, directional arrows may be applied within the bicycle lane.)



4.2.1.2 Signs

Signing is required to indicate to cyclists and motorists the exact location of the bicycle lane, and to alert them to the introduction of a facility. A sign is also available to remind motorists to yield when crossing a cyclist's line of travel.

be attached below the first Rb-84 or Rb-84A sign. If TAC signs are being used, the Reserved Bicycle Lane Ends sign RB-92 should be installed at the end of the reserved lane instead of the RB-90 or RB-91 sign.

Reserved Bicycle Lane Signs

A Reserved Bicycle Lane sign must be used to designate an on-road lane for the exclusive use of cyclists. Practitioners should use the OTM signs shown in **Figure 4.20a** and **4.20b** or the signs found in the TAC *Bikeway Traffic Control Guidelines for Canada*, as illustrated in **Figure 4.21**. Where the bicycle lane is immediately adjacent to the curb, the ground-mounted version of the Reserved Bicycle Lane sign Rb-84A (OTM) or RB-91 (TAC) should be installed. Otherwise, the overhead mounted version of the Reserved Bicycle Lane sign Rb-84 (OTM) or RB-90 (TAC) should be installed on a cantilever and centred above the designated lane. Where OTM signs are used, the standard Reserved Lane Ends tab sign (Rb-85t) in **Figure 4.20b** must be attached below the last Rb-84 or Rb-84A standard Reserved Bicycle Lane sign, and the Begins tab sign (Rb-84t) may

Figure 4.20a – Overhead and Ground-mounted Reserved Bicycle Lane Signs (OTM)

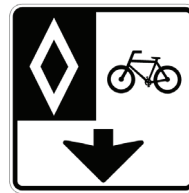

Rb-84 (OTM)
(600 mm x 600 mm)



Rb-84A (OTM)
(600 mm x 600 mm)

Figure 4.20b – Reserved Lane Begins and Ends Tab Signs (OTM)



Rb-84t (OTM)
(200 mm x 600 mm)



Rb-85t (OTM)
(200 mm x 600 mm)

Figure 4.21 – Reserved Bicycle Lane Signs (TAC)



RB-90 (TAC)
(600 mm x 750 mm)



RB-91 (TAC)
(600 mm x 750 mm)



RB-92 (TAC)
(600 mm x 750 mm)

The placement of this sign along a bicycle lane is discussed for various design applications in **Section 4.2.1.4**. The frequency of the reserved bicycle lane sign between intersections should be determined through engineering judgement based on the speed of bicycles and other traffic, as well as the distances between intersections. The maximum spacing is 200 metres and the signs should be repeated after every intersection.

Oversize versions of the Reserved Bicycle Lane sign and tab signs may be used in areas where traffic conditions warrant greater visibility. Practitioners should refer to *OTM Book 5 – Regulatory Signs* for details on this sign. Section 9.2 of that book includes other details on Reserved Lane Signs which may be used to designate an on-road lane for the preferential use of cyclists along with other vehicle classes such as high occupancy or transit vehicles.

Reserved Bicycle Lane Ahead

This sign, shown in **Figure 4.22**, may be placed adjacent to or above the curb lane in advance of the start of a reserved bicycle lane. This sign should be considered where motorists are required to modify their trajectory in order to avoid the bicycle lane.

Figure 4.22 – Reserved Bicycle Lane Ahead Sign



Source: TAC Bikeway Traffic Control Guidelines for Canada, 2012 (Section 4.5.4, p. 36)

Turning Vehicles Yield to Bicycles Sign

The Turning Vehicles Yield to Bicycles sign RB-37 (TAC), illustrated in **Figure 4.23**, may be used at conflict zones where motorists turn across a bicycle facility and are required to yield to the cyclist. In the case of conventional bike lanes, this will occur where there is a solid bike lane marking all the way to the stop bar indicating that right-turning vehicles must not encroach on the bike lane on the approach to an intersection. The sign should incorporate the type of bicycle facility marking or treatment present in the conflict zone. In addition to or instead of the Turning Vehicles Yield to Bicycles sign, practitioners may consider applying green surface treatment as described in **section 4.2.1.4**.

Figure 4.23 – Turning Vehicles Yield to Bicycles Sign

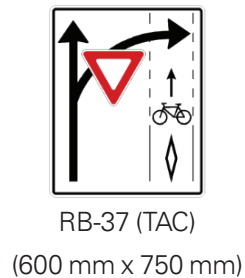

Source: TAC Bikeway Traffic Control Guidelines for Canada, 2012 (Section 3.2.3, p. 15)

4.2.1.3 Pavement Markings

Bicycle lanes are typically demarcated by a 100-millimetre solid white lane line, as shown in **Figure 4.24**, and are marked by two white symbols: a diamond and a bicycle. The diamond symbol should be centred in the bicycle lane and should have a stroke width of at least 75 millimetres. These pavement markings must be used in conjunction with a Reserved Bicycle Lane sign (please refer to **Section 4.2.1.2**).

The placement of the symbols along a bicycle lane is discussed for various design applications in **Section 4.2.1.4**. On roadway segments with long distances between intersections and driveways, the symbols may be repeated at intervals of 300 metres or more. On roadway segments with frequent occurrences of driveways, the symbol spacing may be reduced to 30 metres.

The dashed white bicycle lane line, shown in **Figure 4.25**, indicates that motor vehicles will frequently cross into the bicycle lane: on the approach to some intersections, for example. Further guidance on the application of this pavement marking is discussed in **Section 4.2.1.4**.

Figure 4.24 – Solid White Bicycle Lane Line



Source: TAC Bikeway Traffic Control Guidelines for Canada, 2012 (Table 7-1)

Figure 4.25 – Dashed White Bicycle Lane Line

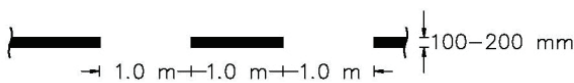

Source: TAC Bikeway Traffic Control Guidelines for Canada, 2012 (Table 7-1)

An optional directional arrow may also be used where the direction of travel is not clear or additional guidance is required. For example, the arrow may be used on contraflow bike lines or at intersections where cyclists will take different trajectories at or on the approach to an intersection depending on the turning movement they are making. The cyclist directional arrow is shown with the bicycle and diamond symbols in **Figure 4.26**.

Figure 4.26 – Bicycle Lane Pavement Markings

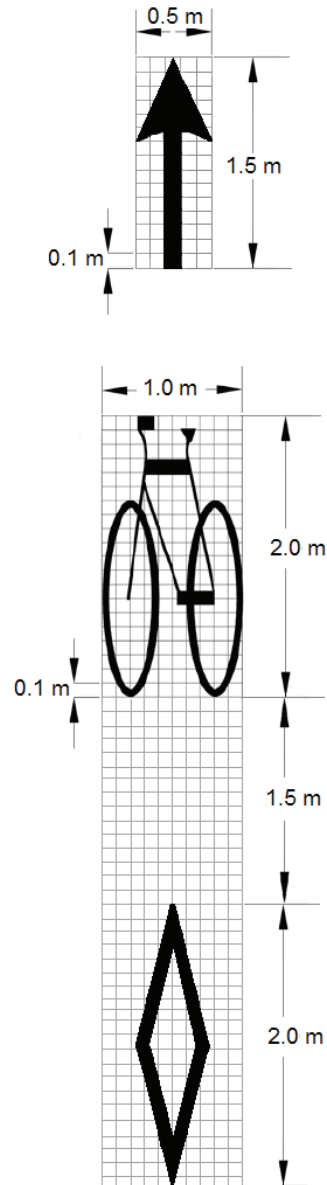

Source: Based on the TAC Bikeway Traffic Control Guidelines for Canada, 2012 (Table 7-1)

4.2.1.4 Design Applications

Bicycle Lane Adjacent to Permanent On-Street Parking

Figure 4.27 illustrates the typical signage for a bicycle lane adjacent to permanent on-street parking. **Figure 4.27** illustrates the typical signage for a bicycle lane adjacent to permanent on-street parking, along with an example pavement marking application. Dashed white bicycle lane lines should be used to indicate where a vehicle may cross into the bicycle facility to exit the parking lane.

It is recommended that a buffer be provided between the parking lane and the bicycle lane. This guides cyclists away from car doors which may open suddenly as passengers alight. Where additional right-of-way is available, it is preferable to have a wider buffer alongside the 1.5-metre bicycle lane for extra protection. Please refer to **Figure 4.19** and **Table 4.3** for guidance.

Figure 4.27 – Bicycle Lane on Two-Lane Two-Way Road with On-Street Parking

(A buffer is recommended where a bicycle lane is adjacent to on-street parking: see Table 4.3. As an option, directional arrows may be applied within the bicycle lane.)

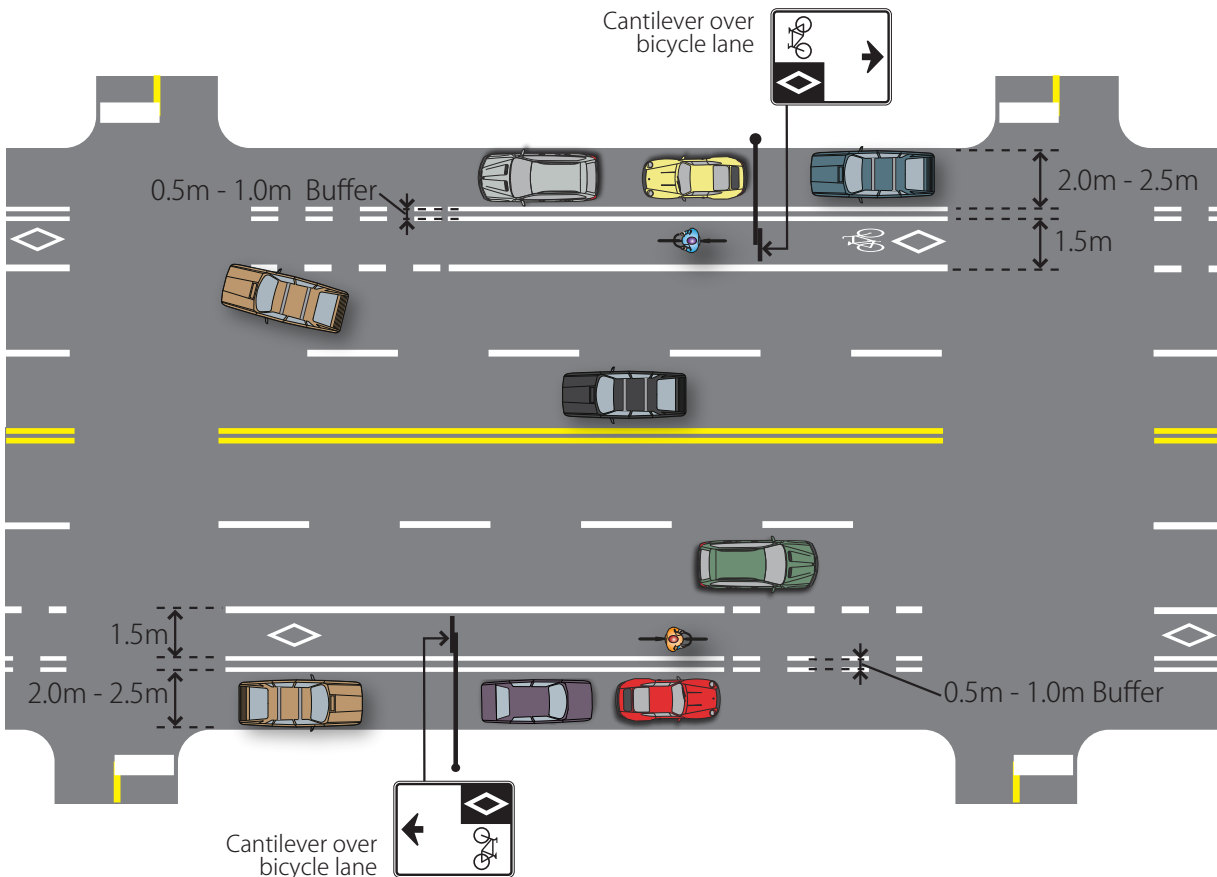

Source: MMM/ALTA, 2013

Introduced and Discontinued Bicycle Lanes

Figures 4.28 to 4.31 illustrate typical design applications for the introduction and discontinuation of a bicycle lane. This includes typical transition zones between a bicycle lane and a shared roadway / signed bicycle route.

Upstream of the initiation of a bicycle lane, the roadway should be signed with a Reserved Bicycle Lane Ahead sign WB-10 (TAC). This sign should be placed no more than 15 metres from the start of the bicycle lane and repeated at least every 200 metres. Repeater signs should also be placed downstream of each intersection along the bicycle lane, at a maximum of 15 metres from the end of

the curb radius. The Reserved Bicycle Lane sign with 'Ends' tab sign should be installed up to 15 metres upstream of the end of the bicycle lane.

Following the end of a bicycle lane, a Share the Road sign Wc-19 (OTM) and supplementary tab Wc-19t (OTM) should be erected to indicate to users that they are entering a shared space. Practitioners should refer to **Section 4.1.1** for guidance on Shared Roadways and signed bicycle routes.

The application of sharrow markings is to guide cyclists through the transition while also raising the motorists' awareness of them. This treatment is optional and should be considered on a site-by-site basis.

Figure 4.28 – Introduced and Discontinued Bicycle Lanes at an Intersection

(As an option, directional arrows may be applied within the bicycle lane and the 'Reserved Bicycle Lane Ahead' sign may be applied. An exclusive right-turn lane or on-street parking may be provided opposite the introduced or discontinued bicycle lane.)

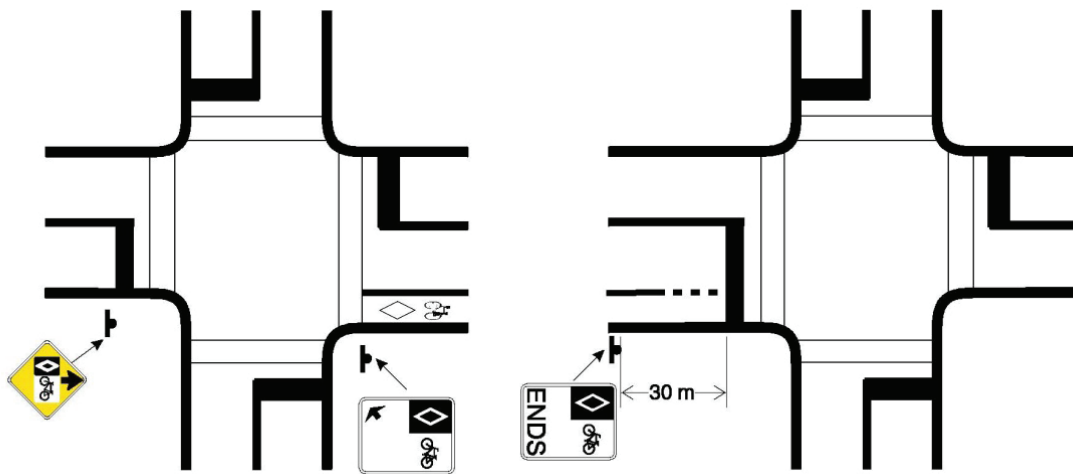

Source: Based on TAC Bikeway Traffic Control Guidelines for Canada, 2012 (Figure 10, p. 72)

Figure 4.29 – Introduced Midblock Bicycle Lane where Roadway Widens

(As an option, directional arrows may be applied within the bicycle lane and the 'Reserved Bicycle Lane Ahead' sign may be applied.)

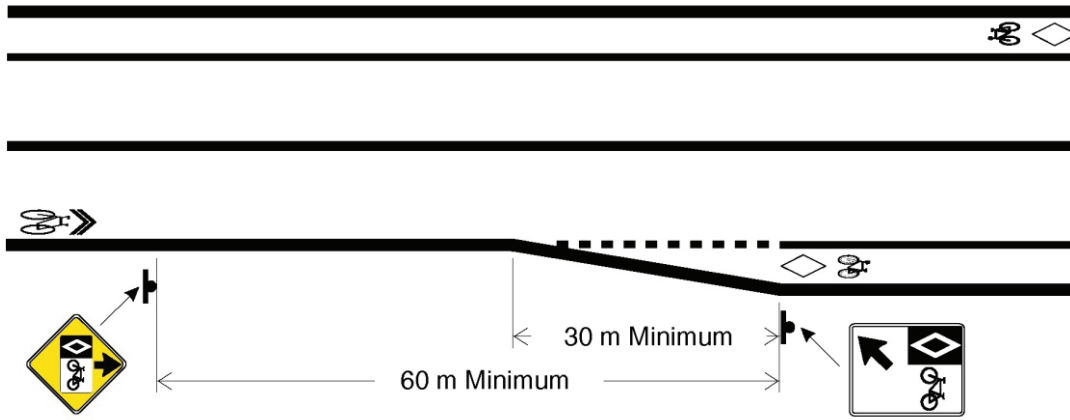

Source: TAC Bikeway Traffic Control Guidelines for Canada, 2012 (Figure 7, p. 70)

Figure 4.30 – Discontinued Midblock Bicycle Lane where Roadway Narrows

(As an option, directional arrows may be applied within the bicycle lane)

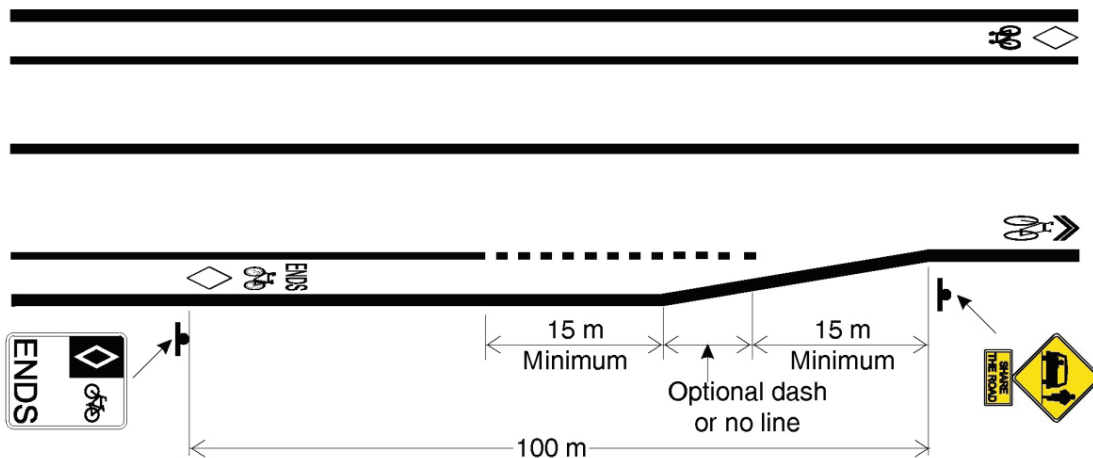

Source: TAC Bikeway Traffic Control Guidelines for Canada, 2012 (Figure 8, p. 70)

Figure 4.31 – Midblock Bicycle Lane (Transition to Through Lane with Shared Facility)

(As an option, directional arrows may be applied within the bicycle lane)

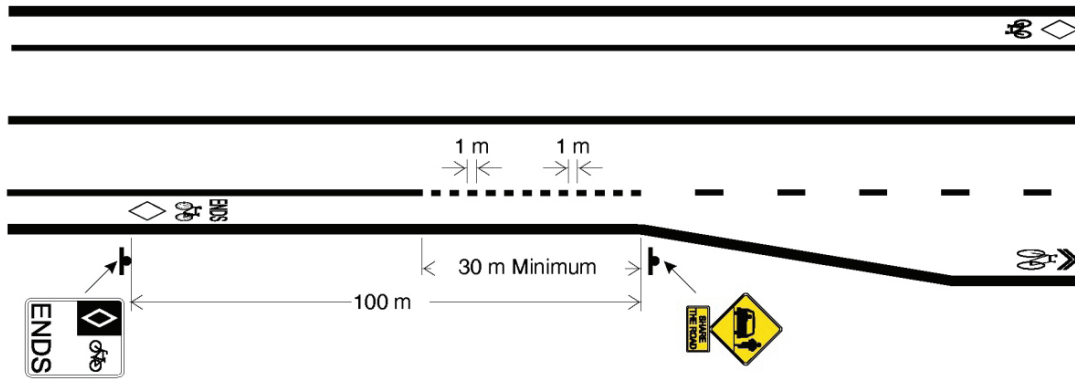

Source: TAC Bikeway Traffic Control Guidelines for Canada, 2012 (Figure 9, p. 71)

Wherever possible, practitioners are encouraged to provide consistent facilities along the entire length of blocks. However, there may be situations where the road width between the curbs remains constant but the effective lane width varies. Where a bicycle lane begins or ends midblock, designers should provide a broken lane line between the curb and the end of the solid bicycle lane line, as shown in **Figure 4.32**. The taper length (measured along

the curb) and the bicycle lane width should have a minimum ratio of 6:1.

Typical Bicycle Lane Transitions at Intersections with Exclusive Right Turn Lanes

On roadways with an exclusive right-turn lane, it is recommended that cyclists navigate to the left of right-turning motorists. By providing this guidance to cyclists and motorists on the approach to the intersection, the potential conflict zone is positioned prior to the intersection where cyclist movements are more visible and predictable to motorists. As a result, right turn conflicts within the intersection can be significantly reduced. Dashed white guide lines indicate where a motor vehicle may cross a cyclist's line of travel.

Figure 4.32 – Tapers for Introduced and Discontinued Bicycle Lanes with No Change in Pavement Width

(See Table 4.3 for desired and suggested minimum widths for bicycle lanes)

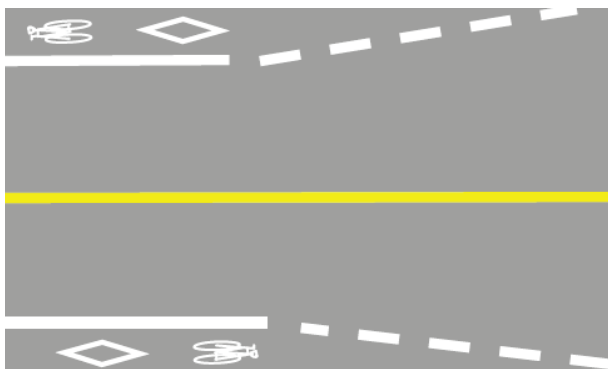

Source: Bicycle Lane Design Guidelines, City of Toronto, 2004.

Figures 4.33 to 4.35 illustrate typical plan views of the transition from a bicycle lane into a shared roadway on the approach to an intersection for roadways with and without on-street parking. In **Figures 4.34 and 4.35**, the sharrow is shown to the left of the turn arrow to indicate to cyclists their recommended placement to continue through the intersection. However, in right-turn lanes less than 4.0m wide, cyclists and motorists will travel in single file.

Figure 4.33 – Bicycle Lane Transition to Shared Through Lane on Road with On-Street Parking

(A buffer is recommended where bicycle lanes are adjacent to on-street parking. See Table 4.3 for desired and suggested minimum widths for bicycle lanes. As an option, directional arrows may be applied within the bicycle lane.)

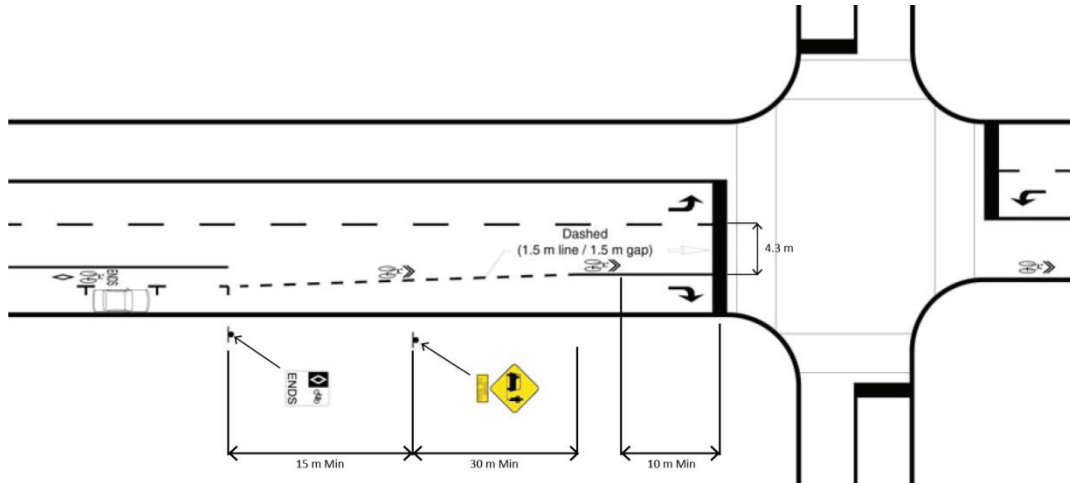

Source: TAC Bikeway Traffic Control Guidelines for Canada, 2012 (Figure 19, p. 76)

Figure 4.34 – Bicycle Lane Transition to Shared Right-Turn (Except Bicycles) Lane on Road with On-Street Parking

(A buffer is recommended where bicycle lanes are adjacent to on-street parking. See Table 4.3 for desired and suggested minimum widths for bicycle lanes. As an option, directional arrows may be applied within the bicycle lane.)

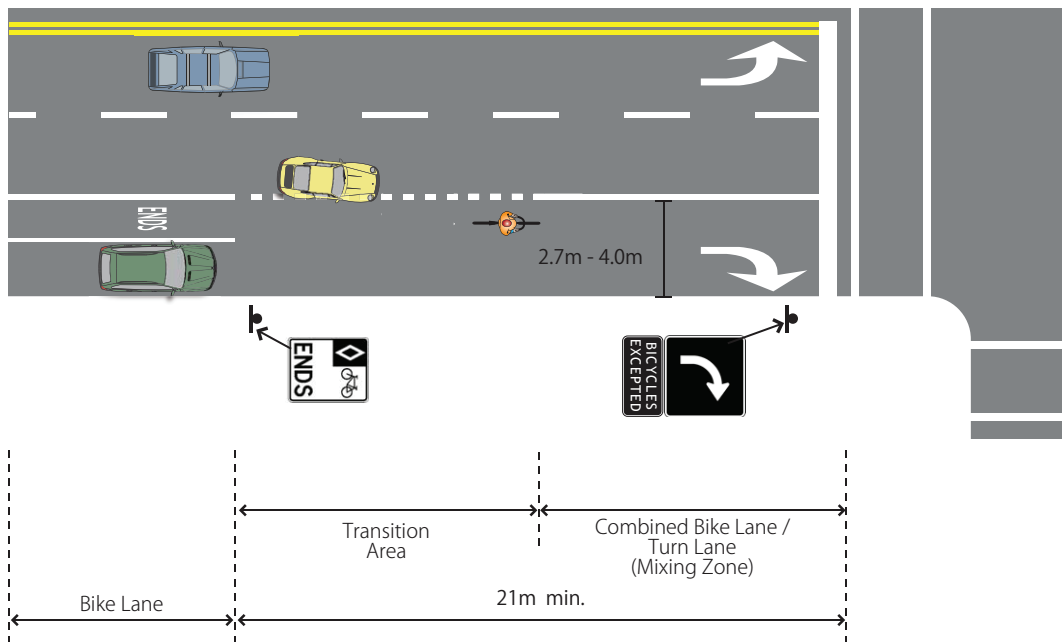

Source: MMM/ALTA, 2013

Figure 4.35 – Bicycle Lane Transition to Shared Right-Turn (Except Bicycles) Lane on Road without On-Street Parking

(See Table 4.3 for desired and suggested minimum widths for bicycle lanes. As an option, directional arrows may be applied within the bicycle lane)

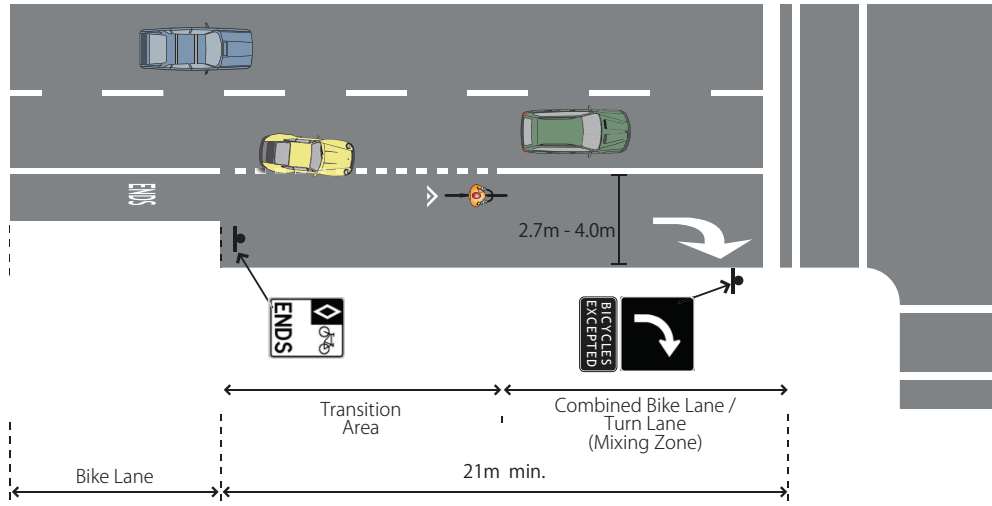

Source: MMM/ALTA, 2013

Figure 4.36 shows a situation where the travel lane alongside a curbside bicycle lane becomes a right-turn lane. Cyclists moving between the marked facilities will use a transition area rather than a

single trajectory, since the path taken by cyclists will depend on their ability to navigate through the right-turning traffic stream.

Figure 4.36 – Bicycle Lane Adjacent to Curb Lane Transition

(See Table 4.3 for desired and suggested minimum widths for bicycle lanes. As an option, directional arrows may be applied within the bicycle lane)

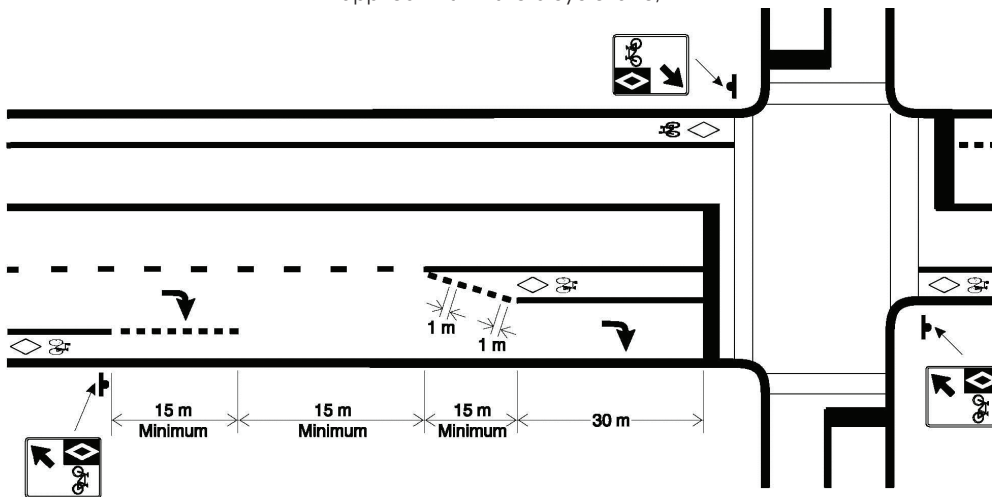

Source: TAC Bikeway Traffic Control Guidelines for Canada, 2012 (Figure 13, p. 73)

Figures 4.37 and 4.38 illustrate typical plan views of alternative designs for a bicycle lane adjacent to an exclusive right-turn lane.

In these cases, right-turning motor vehicles cross the path of through cyclists. The figures show dashed pavement markings delineating these

conflict zones. In addition to this, the practitioner may choose to apply optional bike stencils, green surface treatment or both.

Elephant's feet markings are reserved for crossrides and should not be used for this purpose.

Figure 4.37 – Bicycle Lane Adjacent to Introduced Right-Turn Lane

(See Table 4.3 for desired and suggested minimum widths for bicycle lanes. As an option, directional arrows may be applied within the bicycle lane)

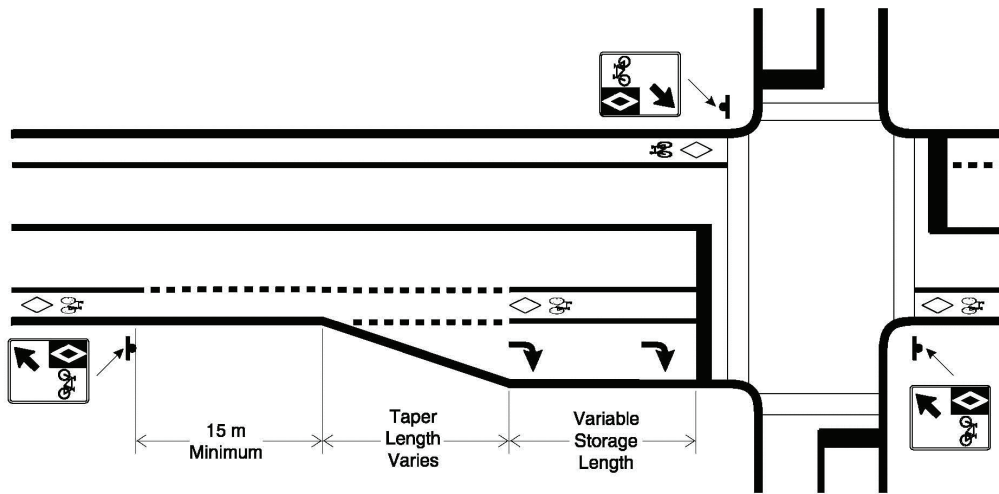

Source: TAC Bikeway Traffic Control Guidelines for Canada, 2012 (Figure 12, p. 73)

Figure 4.38 – Bicycle Lane Adjacent to Parking and Introduced Right-Turn Lane

(A buffer should be considered where bicycle lanes are adjacent to on-street parking and space permits. See Table 4.3 for desired and suggested minimum widths for bicycle lanes. As an option, directional arrows may be applied within the bicycle lane.)

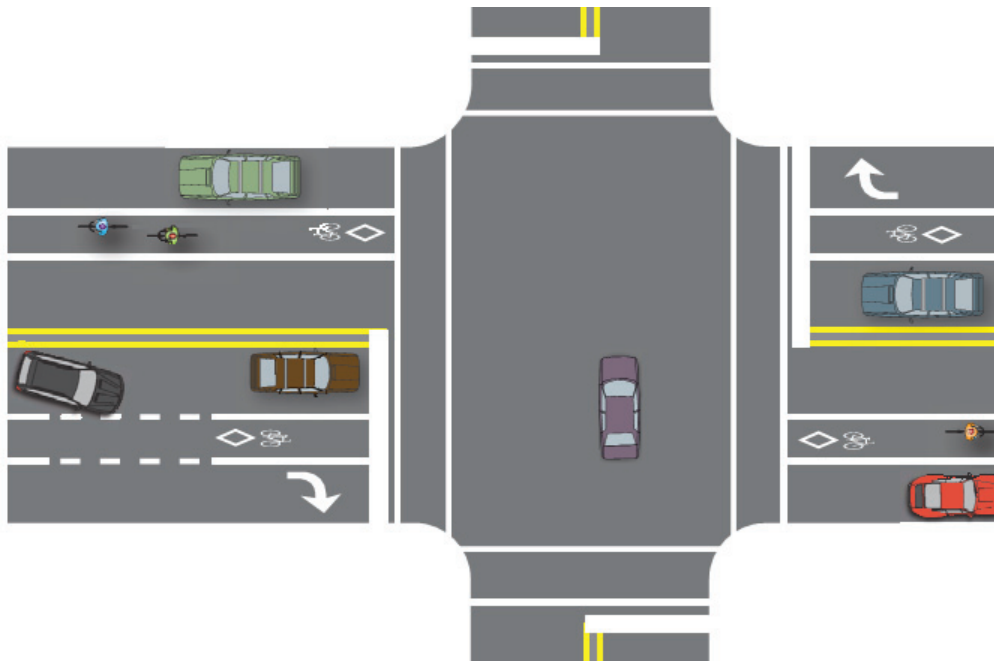

Source: MMM/ALTA, 2013

Typical Bicycle Lane Transitions at Intersections with Shared Through / Right-Turn Lanes

On roadways with a shared through / right-turn motor vehicle lane, there are three alternate solutions that can be considered for the design of the bicycle lane on the approach to the intersection.

Figure 4.39 illustrates a bicycle lane with a minimum 15 metre dashed line on the approach to the intersection, consistent with the TAC *Bikeway Traffic Control Guidelines for Canada*. This treatment indicates to motorists that they are permitted to cross into the bicycle lane (when safe to do so) to make a right turn.

Figure 4.40 depicts a bicycle lane with a solid line on the approach to the intersection. This treatment

discourages motorists from entering the bicycle facility on the approach to the intersection when making a right turn. This makes it easier for cyclists to reach the intersection since their lane will not be blocked by motor vehicles. Thus, cyclists can make right turns on red more easily.

Figure 4.41 shows an optional staggered stop bar treatment. This allows cyclists to position themselves ahead of motorists during a red signal indication, which makes them more visible to right-turning motorists.

Where the path of right-turning vehicles crosses that of cyclists travelling through the intersection, motorists are expected to yield. To clarify this, and to mitigate the risk of drivers not looking for cyclists

in their blind spot, practitioners may choose to provide pavement markings or treatment through the intersection. This will highlight the conflict areas between cyclists and motor vehicles so that each user group is more aware of the other. It may also help to guide cyclists between facilities on either side of the intersection. The available treatment options in increasing order of visibility are:

- no treatment;
- bike stencils or chevrons at 1.5 m to 10 m spacing (with optional directional arrows to clarify cyclists' trajectories);
- sharrows at 1.5 m to 15 m spacing;
- dashed guide lines (with optional bike stencils or chevrons but not sharrows);
- green surface treatment; or
- dashed guide lines (with optional bike stencils or chevrons but not sharrows) and green surface treatment.

Elephant's feet markings are reserved for crossrides at intersections. They should not be marked through the central portion of intersections themselves.

Figure 4.39 – Bicycle Lane Adjacent to Combined Through / Right-Turn Lane (Dashed Line)

(See Table 4.3 for desired and suggested minimum widths for bicycle lanes. As an option, directional arrows may be applied within the bicycle lane)

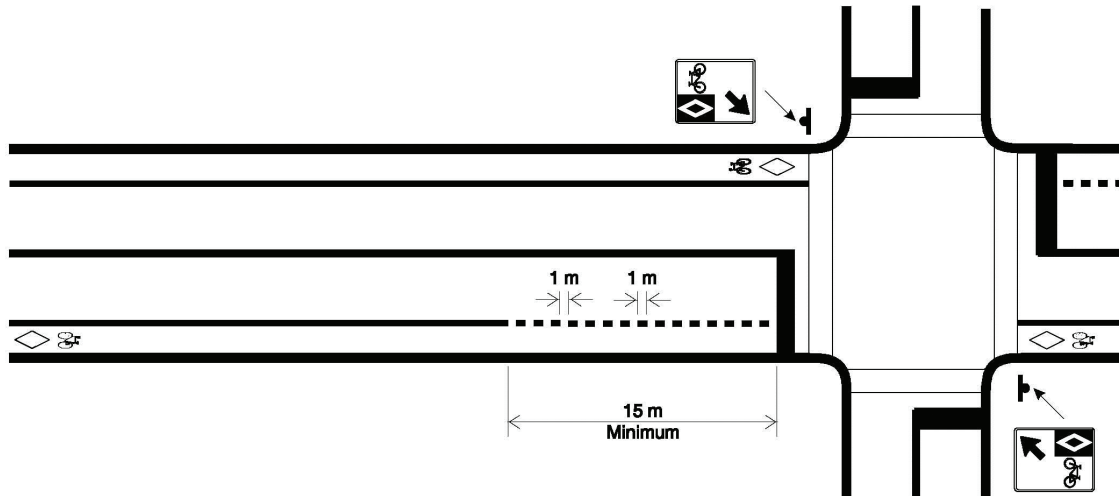

Source: TAC Bikeway Traffic Control Guidelines for Canada, 2012 (Figure 11, p. 72)

Figure 4.40 – Bicycle Lane Adjacent to Combined Through / Right-Turn Lane (Solid Line)

(See Table 4.3 for desired and suggested minimum widths for bicycle lanes. As an option, directional arrows may be applied within the bicycle lane)

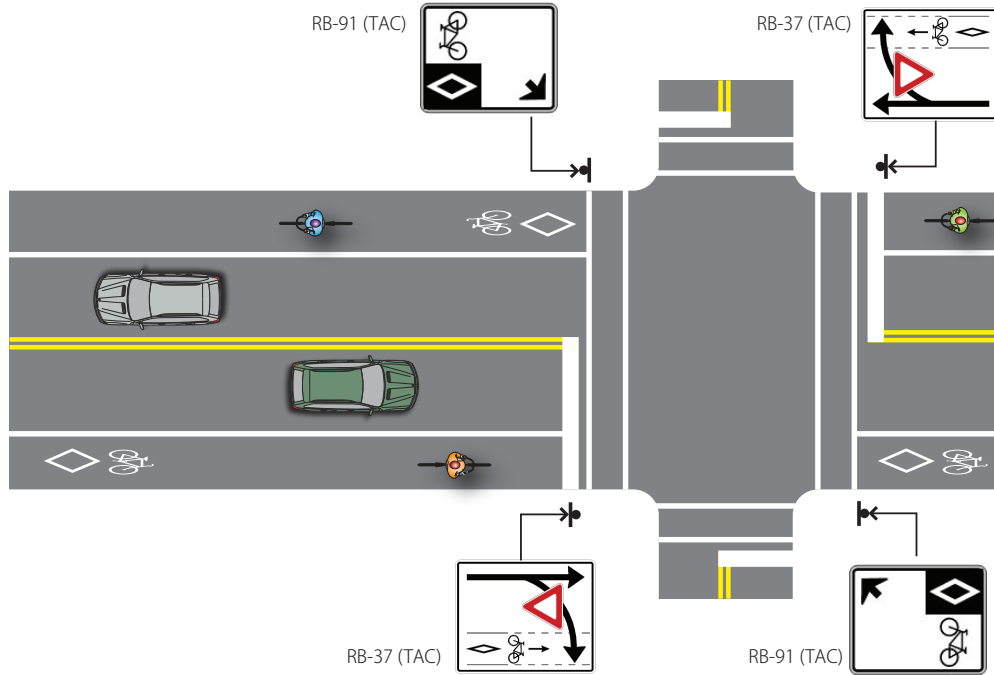

Source: MMM/ALTA, 2013

**Figure 4.41 – Bicycle Lane Adjacent to Combined Through / Right-Turn Lane
(Solid Line with Optional Staggered Stop Bars)**

(See Table 4.3 for desired and suggested minimum widths for bicycle lanes. As an option, directional arrows may be applied within the bicycle lane)

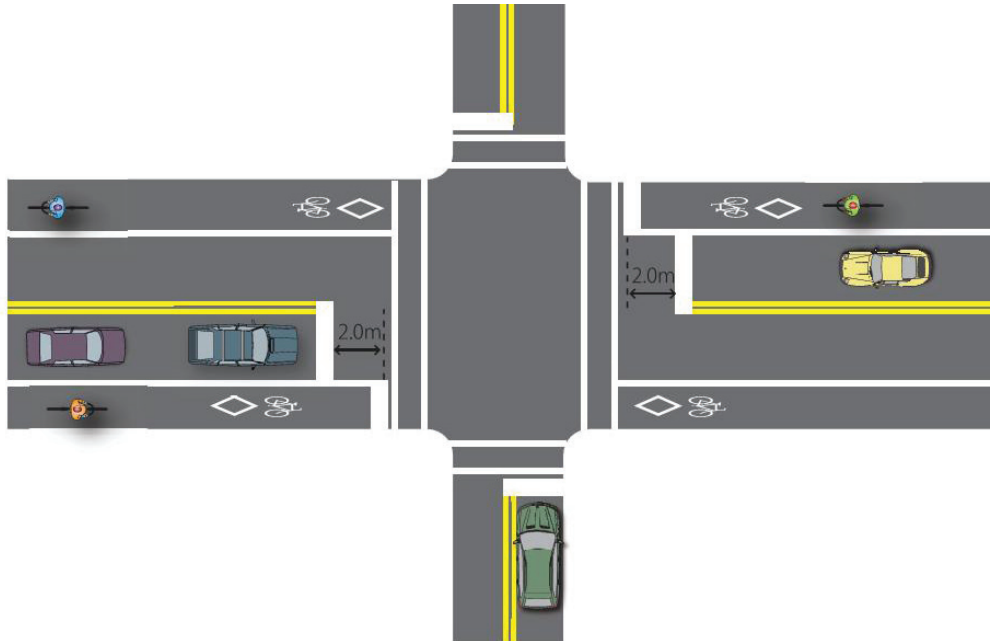

Source: MMM/ALTA, 2013

Pavement Markings at Intersections / Conflict Zones for Through Moving Cyclists

Intersections are shared space zones. The entirety of the area where two streets intersect can be used by all vehicles, including cyclists. At certain locations, there may be a benefit to providing pavement markings or treatment through the intersection. Such markings may help to guide cyclists between facilities on either side of the intersection. They also highlight conflict areas where cyclists and motor vehicles will cross paths so that each user group is more aware of the other. The designer should consider whether and how to intersections may be marked. The available treatment options in increasing order of visibility are:

- no treatment;
- bike stencils or chevrons at 1.5 m to 10 m spacing (with optional directional arrows to clarify cyclists' trajectories);
- sharrows at 1.5 m to 15 m spacing;
- dashed guide lines (with optional bike stencils or chevrons but not sharrows);
- green surface treatment; or
- dashed guide lines (with optional bike stencils or chevrons but not sharrows) and green surface treatment.

Elephant's feet markings are reserved for crossrides at intersections. They should not be marked through the central portion of intersections themselves.

Municipalities should be consistent in whatever application they select for marking conventional bike lanes and separated bike lanes through intersections. This includes the option of no treatment.

One situation where intersection markings may be particularly beneficial to cyclists and motorists is the case where the bicycle lanes on either side of the intersection are not directly aligned with each other.

Where practitioners decide to apply markings or a treatment, this should align with the edges and match the width of the leading and following bicycle facilities.

Figure 4.42 illustrates an example where dashed guide lines have been selected for application through an intersection.

Figure 4.43 shows an alternative application with sharrow markings. It is not recommended to combine sharrows with any other treatment within the intersection, be it guide lines or green surface treatment. The spacing of the sharrows should be between 1.5 and 15 metres.

Figure 4.42 – Guide Lines for Through Moving Cyclists

(See Table 4.3 for desired and suggested minimum widths for bicycle lanes. As an option, directional arrows may be applied within the bicycle lane)

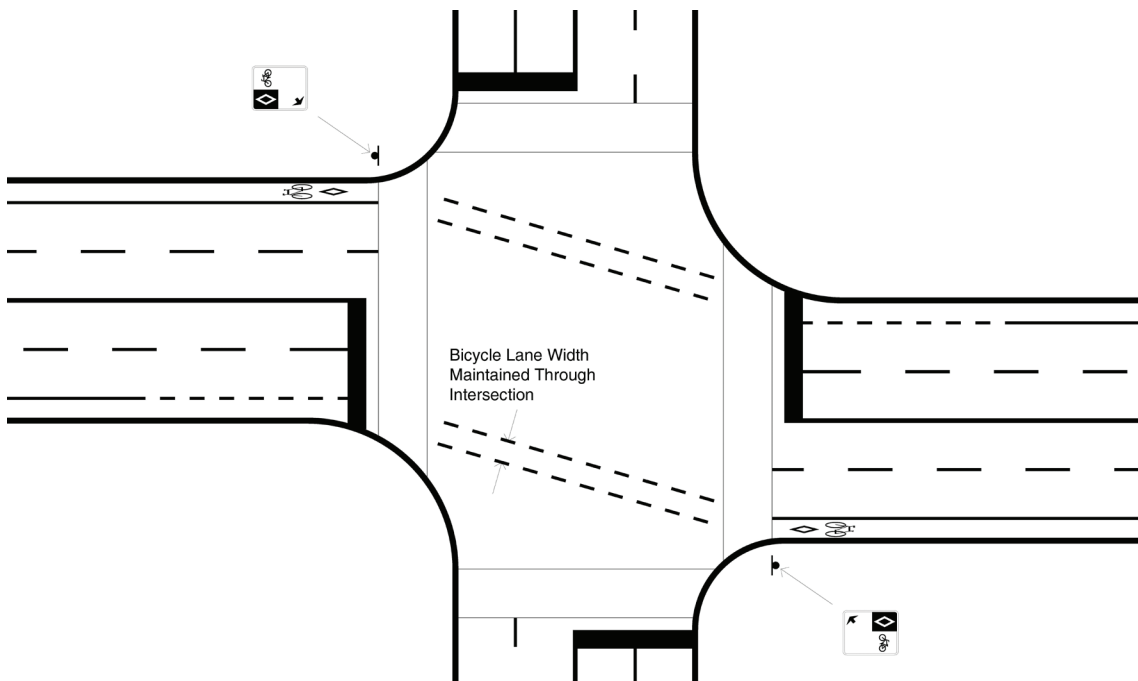

Source: TAC Bikeway Traffic Control Guidelines for Canada, 2012 (Figure 23, p. 80)

Figure 4.43 – Optional Sharrow Application in an Intersection

(See Table 4.3 for desired and suggested minimum widths for bicycle lanes. As an option, directional arrows may be applied within the bicycle lane)

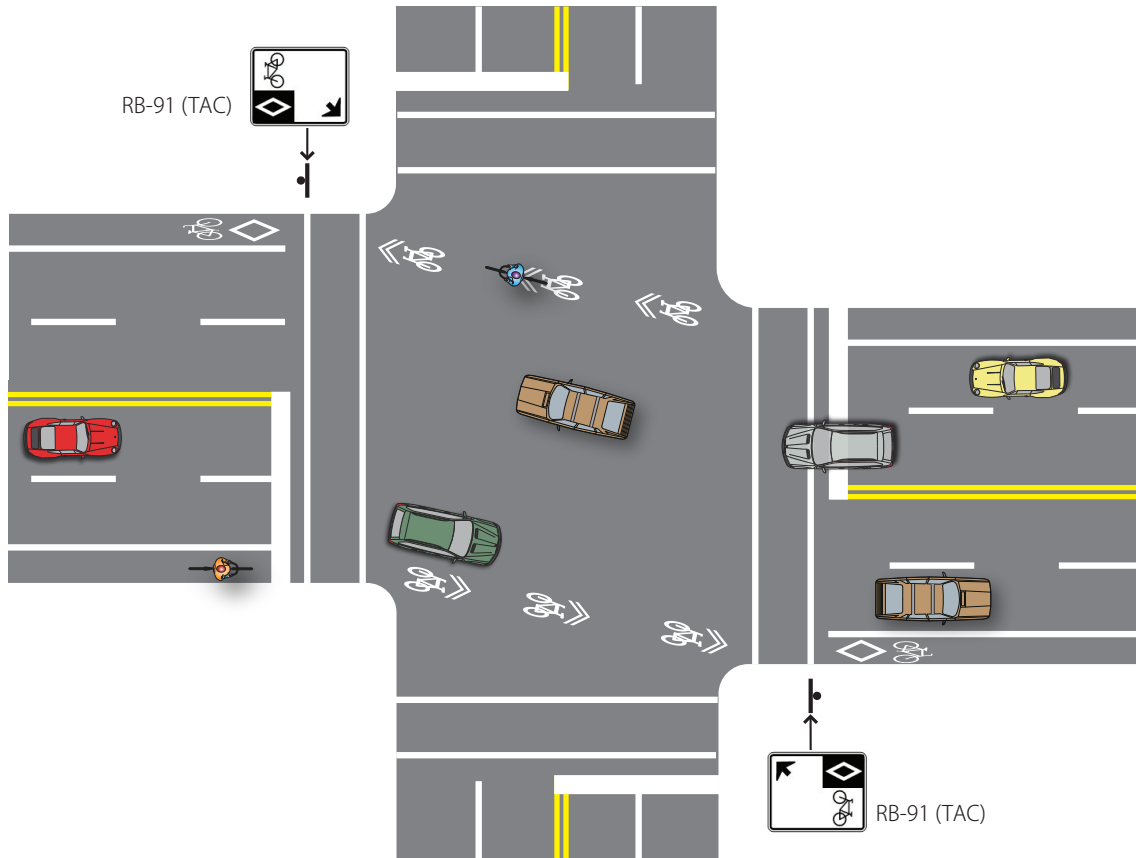

Source: MMM/ALTA, 2013

Typical Bicycle Lane Applications Downstream of Intersections

Figures 4.44 to 4.47 illustrate various design treatments on the downstream side of the intersection, which may consist of a bus bay or a far-side lane drop. In each of these situations, the bicycle lane following the intersection remains aligned with the bicycle lane preceding the

intersection. Where the geometry of the roadway necessitates that motor vehicles cross the bicycle lane, the practitioner should consider using the aforementioned hierarchy of markings and treatments to indicate the conflict zone.

Where sharrow markings or stencils are applied, the minimum separation should be 1.5 metres. Refer to **Section 5.4.1** for more information.

Figure 4.44 – Bicycle Lane Adjacent to Merge Lane with Island

(See Table 4.3 for desired and suggested minimum widths for bicycle lanes. As an option, directional arrows may be applied within the bicycle lane)

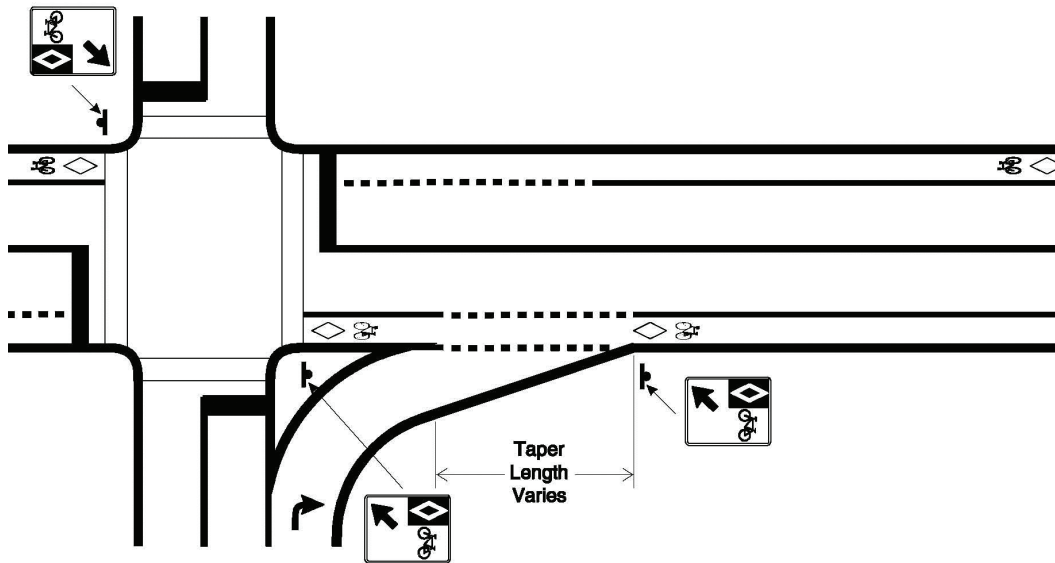

Source: TAC Bikeway Traffic Control Guidelines for Canada, 2012 (Figure 15, p. 74)

Figure 4.45 – Bicycle Lane Adjacent to Far Side Bus Bay

(See Table 4.3 for desired and suggested minimum widths for bicycle lanes. As an option, directional arrows may be applied within the bicycle lane)

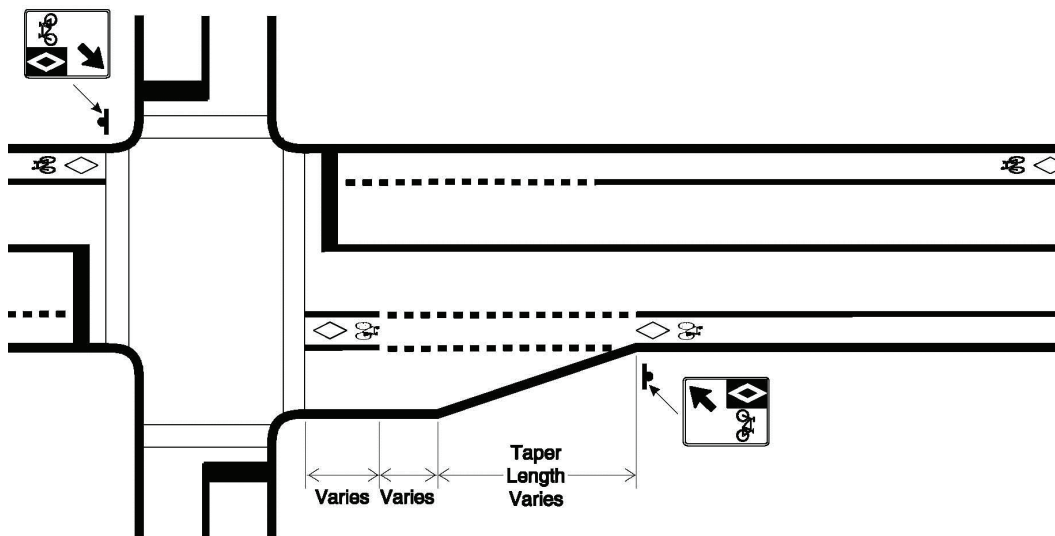

Source: TAC Bikeway Traffic Control Guidelines for Canada, 2012 (Figure 16, p. 75)

Figure 4.46 – Bicycle Lane Adjacent to Right-Turn Lane and Downstream Merge Lane

(See Table 4.3 for desired and suggested minimum widths for bicycle lanes. As an option, directional arrows may be applied within the bicycle lane)

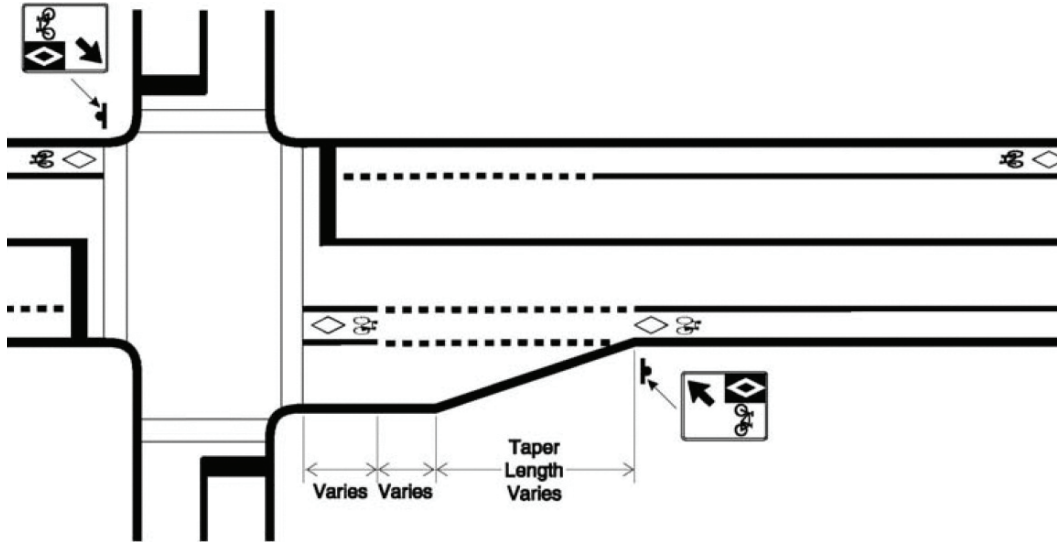

Source: TAC Bikeway Traffic Control Guidelines for Canada, 2012 (Figure 17, p. 75)

Figure 4.47 – Bicycle Lane Adjacent to Shared Through / Right-Turn Lane and Downstream Merge Lane

(See Table 4.3 for desired and suggested minimum widths for bicycle lanes. As an option, directional arrows may be applied within the bicycle lane)

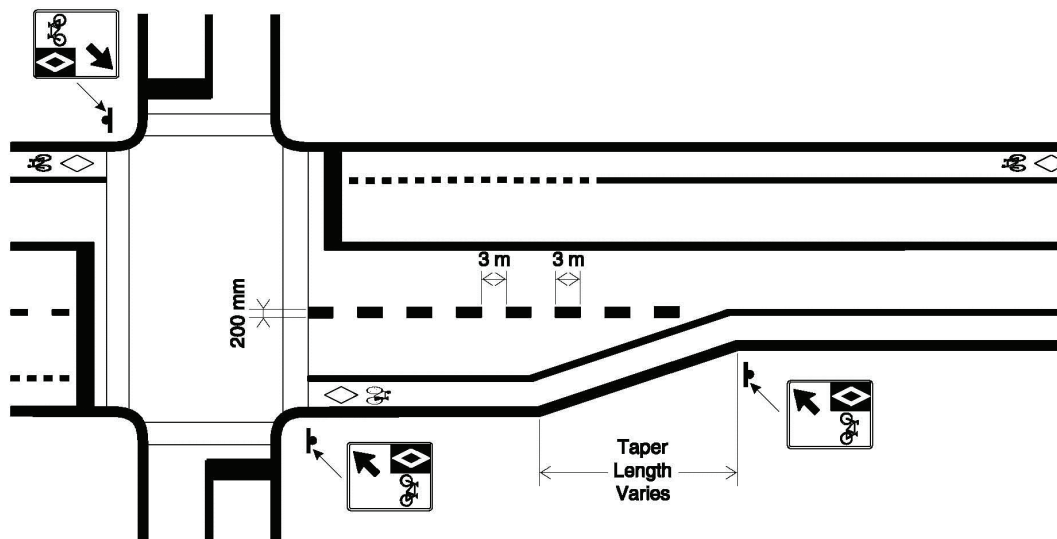

Source: TAC Bikeway Traffic Control Guidelines for Canada, 2012 (Figure 18, p. 76)

Typical Bicycle Lane Applications for Left Turning Cyclists

At an intersection where two roadways with bicycle lanes meet, consideration should be given to facilitating left-turn cycling manoeuvres. **Figure 4.48** illustrates a typical plan view of an intersection with a separate left-turn bicycle lane ‘slot’ or ‘pocket’. Cyclists intending to make a left turn are expected to weave safely across the motor vehicle lanes prior to entering the bicycle lane slot. Designers may provide sharrow markings, or dashed guide lines as shown in **Figure 4.49**, to assist left-turning cyclists through the intersection

from the turning slot to the bicycle lane on the far side of the intersection. On roads with multiple through lanes in each direction, practitioners may consider the application of left-turn queue boxes to assist less confident cyclists, as described later in this section. See **Figure 4.51** and **Section 4.2.2.4** for more information.

An alternative design solution for left-turning cyclists, which may be implemented for a T-intersection and where road right-of-way is available, features a left turn bicycle jug handle. Practitioners should refer to **Section 4.4.1.4** for further details on this design application.

Figure 4.48 – Exclusive Left-Turn Bicycle Lane Slot

(On roads with multiple through lanes in each direction, practitioners may consider the application of left turn queue boxes to assist less confident cyclists. See Table 4.3 for desired and suggested minimum widths for bicycle lanes. As an option, directional arrows may be applied within the bicycle lane.)

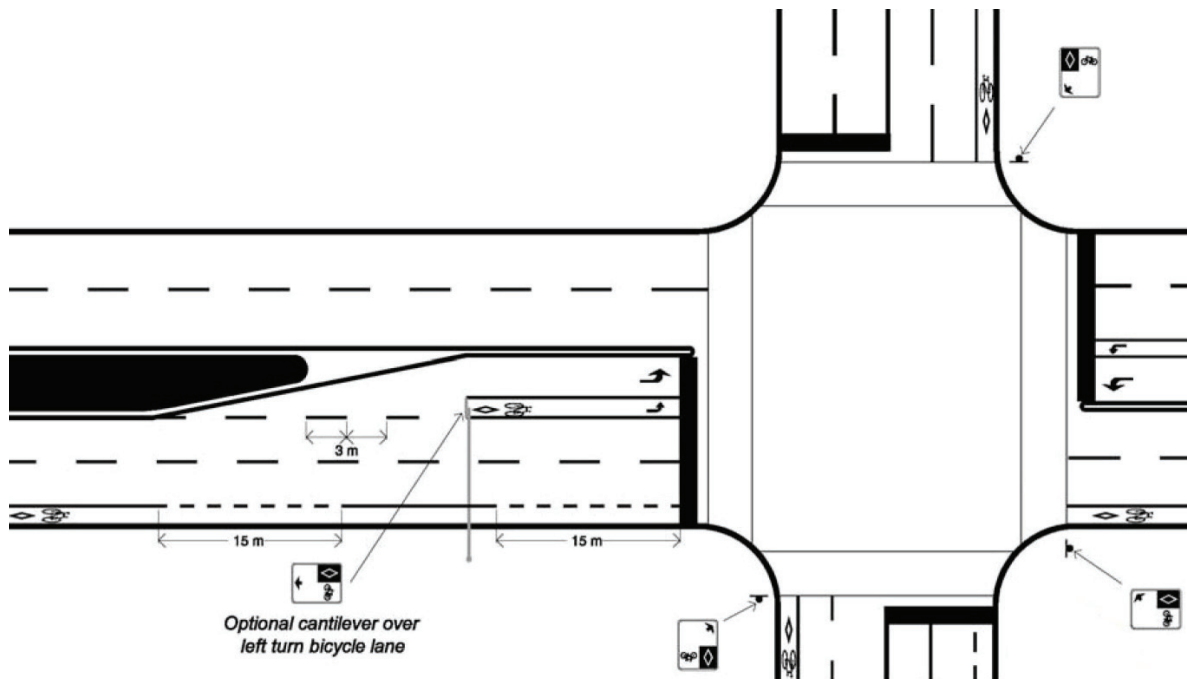

Source: Based on TAC Bikeway Traffic Control Guidelines for Canada, 2012 (Figure 14, p. 74)

Figure 4.49 – Left-Turn Bicycle Lane Guide Lines Through Intersection

(See Table 4.3 for desired and suggested minimum widths for bicycle lanes. On roads with multiple through lanes in each direction, practitioners may consider the application of left-turn queue boxes to assist less confident cyclists.)

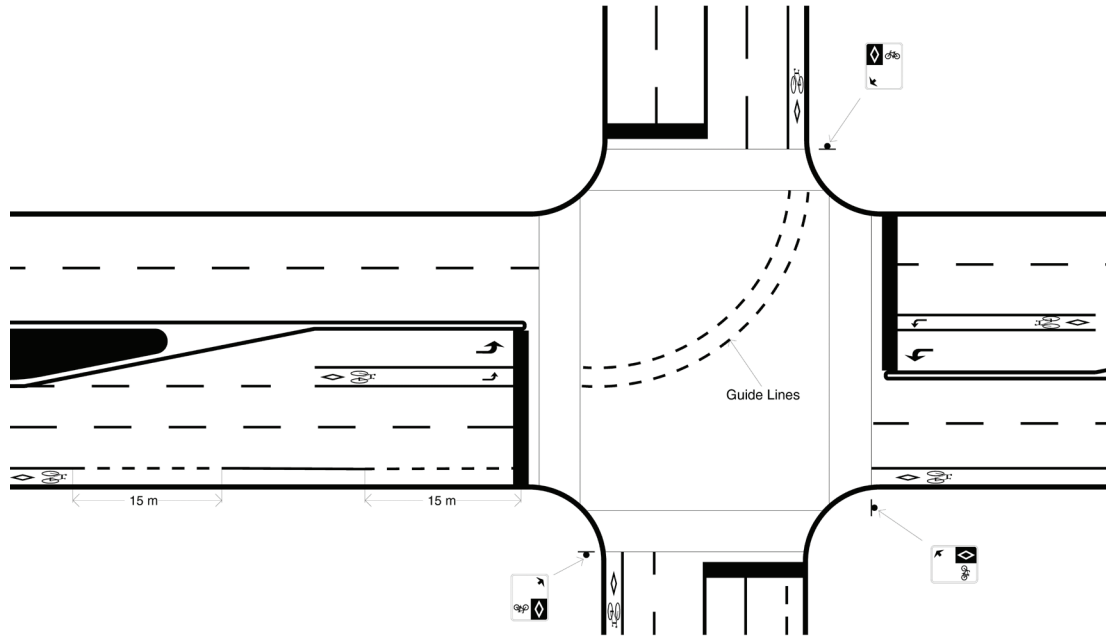

Source: Based on the TAC Bikeway Traffic Control Guidelines for Canada, 2012 (Figure 24, p. 80)

Bike Box

A bike box is a designated area placed between the crosswalk and the stop bar for motorized traffic at a signalized intersection. This enables cyclists to wait ahead of queuing traffic during the red signal indication before proceeding ahead of motorists on the green indication. This designated area significantly increases the visibility of cyclists, making motorists more aware of their presence. If the bike box extends across the entire intersection approach, cyclists can transition from the right side of the roadway towards the left during a red indication in order to make a left turn movement rather than weaving through motorized traffic.

Practitioners should consider providing bike boxes at intersections with high motor vehicle volumes, (especially right turns) and where large numbers of cyclists may be expected. In particular, bike boxes should be provided where a bicycle route turns left or connects with another designated facility, or at any other intersection with high left-turn cyclist movements.

The depth of the bike box, specifically the distance between the crosswalk and the vehicular stop bar, should be 5.0 metres to cater to the volume of cyclists as well as bicycles with trailers. In constrained situations, this may be reduced to a minimum of 4.0 metres. Bicycle pavement marking

symbols should be applied between the crosswalk and the stop bar for motor vehicles. Green surface treatment may also be considered to enhance the visibility of the bike box.

In order to make a right turn on red, motorists will have to cross into the bike box, potentially waiting within it for a gap in traffic to complete their manoeuvre. This may prevent cyclists from accessing the entirety of their designated area.

There is also potential for a conflict between cyclists transitioning from the right side of the roadway to the left side of the bike box during a red signal indication in order to make a left turn movement. Consequently, designers should consider restricting right turns on red where bike boxes are present, in particular during peak traffic periods.

Figure 4.50 illustrates an example of a bike box application.

Figure 4.50 – Bike Box Design

(Standard sized bicycle symbols may be used within the bike box if desired. See Table 4.3 for desired and suggested minimum widths for bicycle lanes. As an option, directional arrows may be applied within the bicycle lane, and right turns on red may be restricted.)

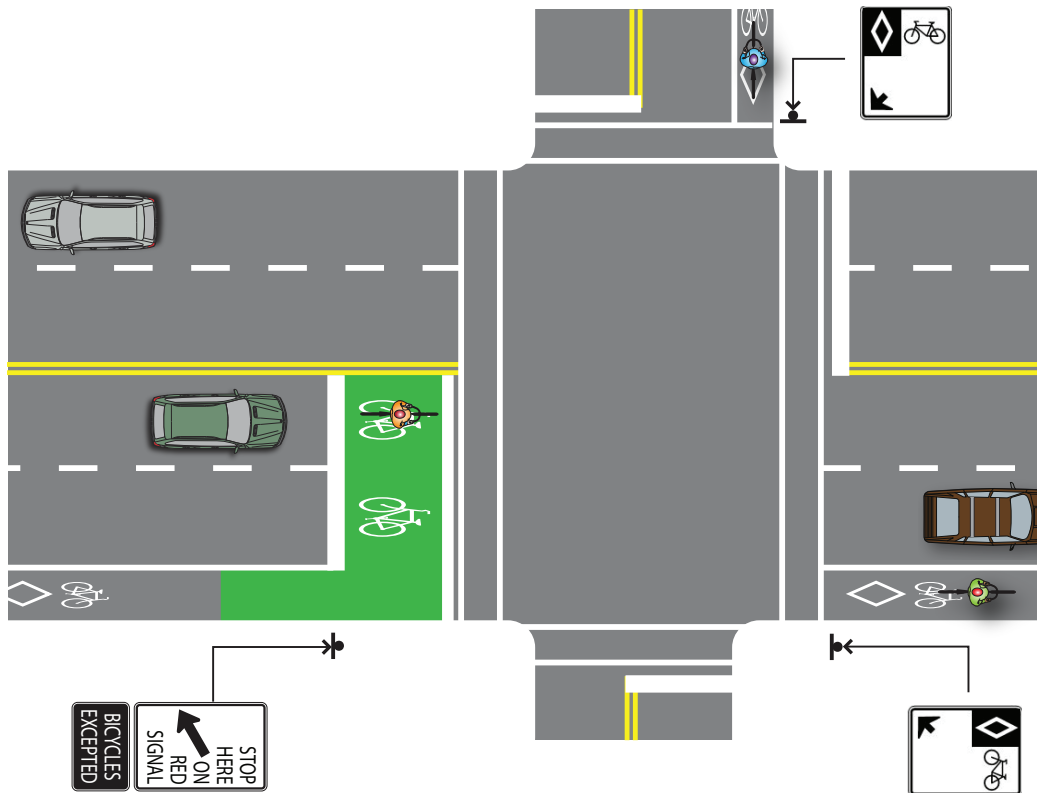

Source: MMM/ALTA, 2013

Two-Stage Left Turn Queue Box

A two-stage left turn queue box is a designated area within the signalized intersection that allows cyclists to safely wait while making a two-stage left turn movement. The queue box should be aligned with a parking lane or be downstream of an exclusive right-turn lane, to the right of the through lanes from the street where the turn is initiated. Although not marked through the intersection, a conventional bike lane or buffer should be provided on the street where the turn is initiated. This will separate the queue box from the path of cyclists who are proceeding straight through the intersection.

This designated space should be marked with a white rectangular or square box using 100 mm wide solid lines surrounding a turn arrow pointing in the direction in which cyclists will leave the intersection, plus a bicycle symbol oriented according to the direction from which they entered.

Cyclists waiting in the left turn queue box will be situated in front of the stop bar of the cross street. At this time the traffic signal indication for the cross street may be red. Given that cyclists in the queue box may obstruct the right turn movement from the cross street, designers should consider restricting this right turn on red.

The queue box concept permitting cyclists to wait in front of the stop bar is new in Ontario. In order to communicate the legitimacy of the facility to drivers and to give cyclists the confidence to place themselves in this location, green surface treatment is required to enhance the visibility of the two-stage left turn queue box.

An example of an intersection design featuring a queue box is shown in **Figure 4.51**. This design feature should also be applied with separated bicycle lanes. Please refer to **Section 4.2.2.4** for more details.

Figure 4.51 – Two-Stage Left Turn Queue Box Aligned with Parking Lane Adjacent to Bicycle Lane

(See Table 4.3 for desired and suggested minimum widths for bicycle lanes. As an option, directional arrows may be applied within the bicycle lane, and right turns on red from the cross street may be restricted.)

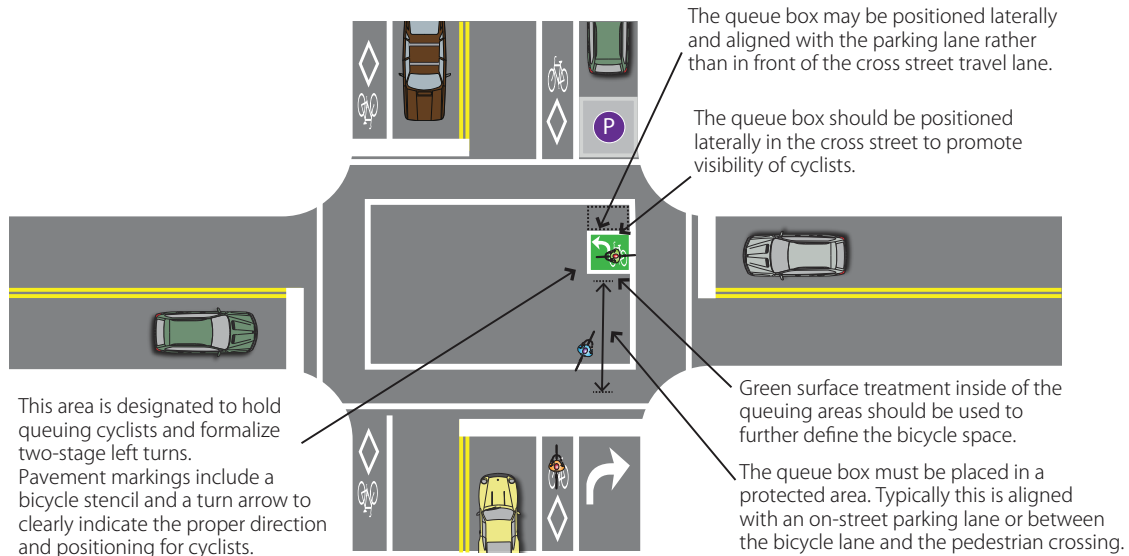

Source: MMM/ALTA, 2013

Jug Handles at Urban T-intersections

At T-intersections, designers may use the space available due to the absence of the fourth leg to install a jug handle. This allows cyclists to reorient themselves to cross the road, and serves a similar function to that of a two-stage left turn queue box in a four-legged intersection. An example is shown in **Figure 4.52**.

This is effectively the fourth leg of the signalized intersection, so practitioners should provide traffic signals that are visible to cyclists waiting there. Bicycle traffic signal heads similar to the ones shown in **Section 5.8.2** may be provided.

The alignment of the jug handle should allow cyclists to easily cross the intersection and access the on-road bicycle facility on the exit leg.

See **Section 4.4.1.4** for guidance on situations where the facility opposite the jug handle is within the boulevard.

Figure 4.52 – An Example of a Jug Handle at an Urban T-intersection



Credit: City of Mississauga

4.2.2 Separated Bicycle Lanes

A Separated Bicycle Lane is a portion of a roadway for preferential or exclusive use by cyclists which is delineated from the motor vehicle lanes by pavement markings or a physical barrier and signage. Physical separation can vary depending on the available width of the right-of-way and preference of the road authority, as well as roadway characteristics such as vehicular speed, volume and type. Some of the more common barrier types include: flexible bollards, concrete curbs, planters, parking lanes and raised medians. **Figure 4.53** shows examples of separated bicycle lanes. Note that not all barrier types completely restrict motor vehicles from the bicycle lane. Designers should consider this when selecting a separation type, particularly where site specific (including driver behaviour) characteristics increase the risk of encroachment.

Separated bicycle lanes are typically implemented on roadways with higher volumes of faster moving traffic and heavy vehicles. The added lateral or physical separation of separated bicycle lanes provides most cyclists with a more comfortable riding environment than shared roadways or conventional bicycle lanes.

Prior to initiating design work on a given link, practitioners should refer to the Bicycle Facility Type Selection process in **Section 3.2.2**. This will confirm whether the separated bicycle lane is the most suitable facility type and identify key design considerations.

4.2.2.1 Geometry

The bicycle lane and separation width depends on the type of buffer, as shown in **Table 4.4**. As with all facility types, designers should implement the desired widths unless restricted by site constraints.

Where practitioners are considering designing the width of either the bicycle lane or the buffer

to less than the desired width, they should give careful consideration to the effective unobstructed width available. The width requirements for street sweeper vehicles are typically 2.0 metres. There are maintenance cost implications should narrow facilities require specialized or manual clearing methods.

Figure 4.54 illustrates typical cross-sections of several varieties of separated bicycle lane. A practitioner may consider reducing the width to a value greater than or equal to the suggested minimum for context specific situations, but only on segments or corridors with constrained right-of-way widths.

This guidance focuses on the provision of unidirectional separated facilities. In some circumstances, however, practitioners may consider installing bidirectional separated facilities. The same desired and minimum lane widths apply (per lane) as those shown in **Table 4.4**. Barrier widths are independent of the number of lanes. Where facilities are vertically separated, practitioners should refer to **Table 4.6** regarding Desired and Suggested Minimum Widths for Raised Cycle Tracks.

Unlike unidirectional facilities, which should be provided on each side of the roadway, bidirectional facilities may be located on one side only. Compared to two unidirectional lanes, bidirectional facilities may offer some savings in terms of installation cost. Restrictions associated with maintenance vehicle operating widths are also eliminated. However, transitioning to shared traffic lanes or conventional bike lanes is more problematic, and they are incompatible with bike boxes. The introduction of bidirectional facilities also leads to considerably greater conflicts with turning motor vehicles at intersections, as described in **Section 5.4.1.2**. Practitioners should consider the mitigation strategies outlined in that section.

Table 4.4 – Desired and Suggested Minimum Widths for Separated Bicycle Lanes^a

Facility	Desired Width	Suggested Minimum
Marked Buffer	1.8 m lane + 1.2 m buffer	1.5 m lane + 0.5 m ^b buffer
Flexible Bollards	2.0 m ^c lane + 1.2 m buffer	1.5 m ^d lane + 0.5 m buffer
Planters / Concrete Curb / Median	2.0 m ^c lane + 1.2 m buffer	1.8 m ^d lane + 0.5 m buffer
On-Street Parking	1.8 m lane + 1.2 m buffer	1.5 m lane + 0.8 m ^e buffer
<p>^aFor bidirectional separated facilities, the same desired and minimum lane widths apply (per lane). Barrier widths are independent of the number of lanes. Where facilities are vertically separated, practitioners should refer to Table 4.6 – Desired and Suggested Minimum Widths for Raised Cycle Tracks.</p> <p>^bMaintenance standards for marked buffers should be the same as for lanes since cyclists may use them for overtaking.</p> <p>^cPractitioners should provide a minimum of 2.0 m effective width between the curb and the physical component of the barrier where high volumes of cyclists are anticipated. This will reduce the risk of cyclists clipping the physical buffer or curb while overtaking other cyclists.</p> <p>^dMaintenance procedures and costs should be considered since small street sweeper vehicles typically require 2.0m of unobstructed running width, otherwise the removal of flex bollards may be required before they can be used. Designers should check the requirements for their municipality and factor in higher maintenance costs should their chosen facility widths require the use of specialized equipment or manual sweeping. See Section 8 for further information on maintenance considerations. Impacts on drainage and garbage collection should also be taken into account.</p> <p>^ePractitioners should provide the widest buffer possible to reduce the risk of a cyclist colliding with an opening car door, recognizing that the space available for avoiding debris or imperfections and overtaking is limited.</p>		

Source: Adapted from AASHTO Guide for Planning, Design and Operation of Bicycle Facilities, 2012

Figure 4.53 – Examples of Separated Bicycle Lanes

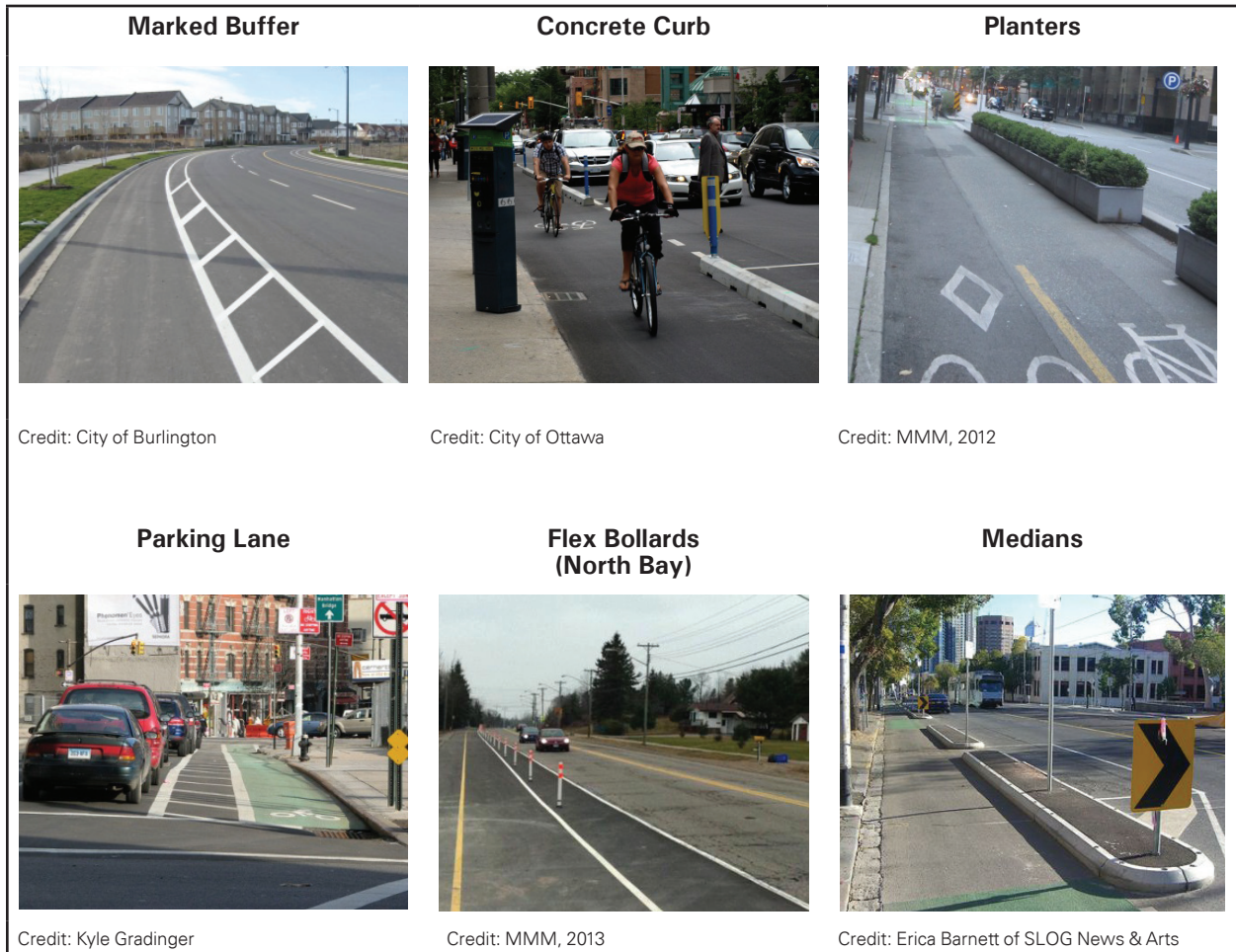
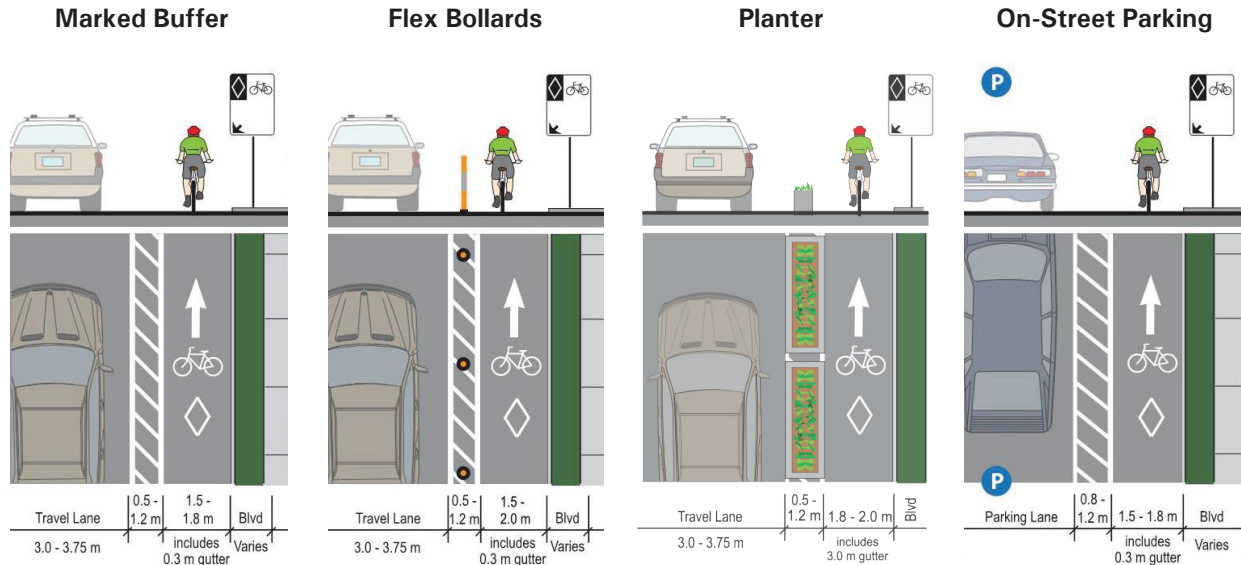

Figure 4.54 – Cross-Sections of Separated Bicycle Lanes with Buffers as indicated

(See Table 4.4 for more details. As an option, directional arrows may be applied within the bicycle lane.)



Source: MMM, 2013

4.2.2.2 Signs

Signing is required to indicate to cyclists and motorists where a lane is for bicycle use only, or to alert them to the introduction of a facility. A sign is also available to remind motorists to yield when crossing cyclists' line of travel.

Reserved Bicycle Lane Signs

A Reserved Bicycle Lane sign must be used to designate an on-road lane for the exclusive use of cyclists. Practitioners should use the OTM signs shown in **Figure 4.55a** and **4.55b** or the signs found in the TAC *Bikeway Traffic Control Guidelines for Canada*, as illustrated in **Figure 4.56**. Where the bicycle lane is immediately adjacent to the curb, the ground-mounted version of the Reserved Bicycle Lane sign Rb-84A (OTM) or RB-91 (TAC) should be

installed. Otherwise, the overhead mounted version of the Reserved Bicycle Lane sign Rb-84 (OTM) or RB-90 (TAC) should be installed on a cantilever and centred above the designated lane. Where OTM signs are used, the standard Reserved Lane Ends tab sign (Rb-85t) in **Figure 4.55b** must be attached below the last Rb-84 or Rb-84A standard Reserved Bicycle Lane sign, and the Begins tab sign (Rb-84t) may be attached below the first Rb-84 or Rb-84A sign. If TAC signs are being used, the Reserved Bicycle Lane Ends sign RB-92 should be installed at the end of the reserved lane instead of the RB-90 or RB-91 sign.

The placement of this sign along a bicycle lane is discussed for various design applications in **Section 4.2.2.4**.

Figure 4.55a – Overhead and Ground-mounted Reserved Bicycle Lane Signs (OTM)



Rb-84 (OTM)
(600 mm x 600 mm)



Rb-84A (OTM)
(600 mm x 600 mm)

Figure 4.55b – Reserved Lane Begins and Ends Tab Signs (OTM)



Rb-84t (OTM)
(200 mm x 600 mm)



Rb-85t (OTM)
(200 mm x 600 mm)

Figure 4.56 – Reserved Bicycle Lane Signs (TAC)

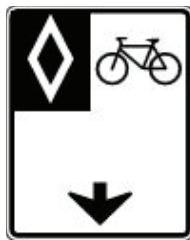

RB-90 (TAC)
(600 mm x 750 mm)

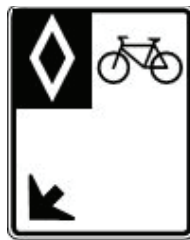

RB-91 (TAC)
(600 mm x 750 mm)



RB-92 (TAC)
(600 mm x 750 mm)

Source: TAC Bikeway Traffic Control Guidelines for Canada, 2012 (Section 3.7.9, p. 24)

The frequency of the reserved bicycle lane sign between intersections should be determined through engineering judgement based on the speed of bicycles and other traffic, as well as the distances between intersections. The maximum spacing is 200 metres and the signs should be repeated after every intersection.

Oversize versions of the Reserved Bicycle Lane sign and tab signs may be used at locations where prevailing traffic conditions warrant greater visibility or emphasis. This can occur in complex visual environments where many signs and other devices compete for driver attention, or at

high traffic volume locations where drivers must concentrate more on the driving task. Practitioners should refer to OTM *Book 5 – Regulatory Signs* for details on this sign.

Reserved Bicycle Lane Ahead

The Reserved Bicycle Lane Ahead sign WB-10 (TAC), shown in **Figure 4.57**, may be placed adjacent to or above the curb lane in advance of a reserved bicycle lane. This sign should be considered where motorists are required to manoeuvre their vehicle in order to avoid the bicycle lane.

Figure 4.57 – Reserved Bicycle Lane Ahead Sign



WB-10 (TAC)
(600 mm x 600 mm)

Source: TAC Bikeway Traffic Control Guidelines for Canada, 2012
(Section 4.5.4, p. 36)

Turning Vehicles Yield to Bicycles Sign

The Turning Vehicles Yield to Bicycles sign RB-37 (TAC), illustrated in **Figure 4.58**, may be used at conflict zones where motorists turn across a bicycle facility and are required to yield to the cyclist. For separated bicycle lanes, this will coincide with locations where the barrier is discontinued to allow for turning vehicles. The sign should incorporate the type of bicycle facility marking or treatment present in the conflict zone. In addition to or instead of the Turning Vehicles Yield to Bicycles sign, practitioners may consider applying green surface treatment as described in **Section 4.2.2.4**.

Figure 4.58 – Turning Vehicles Yield to Bicycles Sign

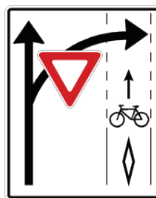

RB-37 (TAC)
(600 mm x 750 mm)

Source: TAC Bikeway Traffic Control Guidelines for Canada, 2012
(Section 3.2.3, p. 15)

4.2.2.3 Pavement Markings

Separated bicycle lanes are marked by two white symbols: a diamond and a bicycle symbol. The diamond symbol should be centred in the bicycle lane and should have a stroke width of at least 75 millimetres. These pavement markings must be used in conjunction with a Reserved Bicycle Lane sign (discussed in **Section 4.2.2.2**). An optional directional arrow may be used where the direction of travel is not clear or additional guidance is required. For example, the arrow may be used on contraflow bike lanes or at intersections where cyclists will take different trajectories at or on the approach to an intersection depending on the turning movement they are making. The cyclist directional arrow is shown with the bicycle symbol and diamond symbol in **Figure 4.59**.

Where intersections are more than 400 metres apart, bicycle symbols should be placed with a minimum spacing of 200 metres. However, the designer may determine that site specific factors require symbols to be placed more frequently to highlight the possible presence of cyclists, such as in conflict zones.

Separated bicycle lanes are typically demarcated by a 100 millimetre solid white lane line, shown in **Figure 4.60**, spaced at least 0.5 metres apart, which defines the buffer between the bicycle lane and the travel lane. Physical barriers may be placed within this buffer space to provide added separation between motorists and cyclists.

Alternatively, the buffer may be delineated by a 100-millimetre solid white line, which defines the boundary between the buffer and the bicycle lane, and a solid white line 100 to 200 millimetres wide, which defines the boundary between the buffer and the travel lane.

Figure 4.59 – Bicycle Lane Pavement Markings

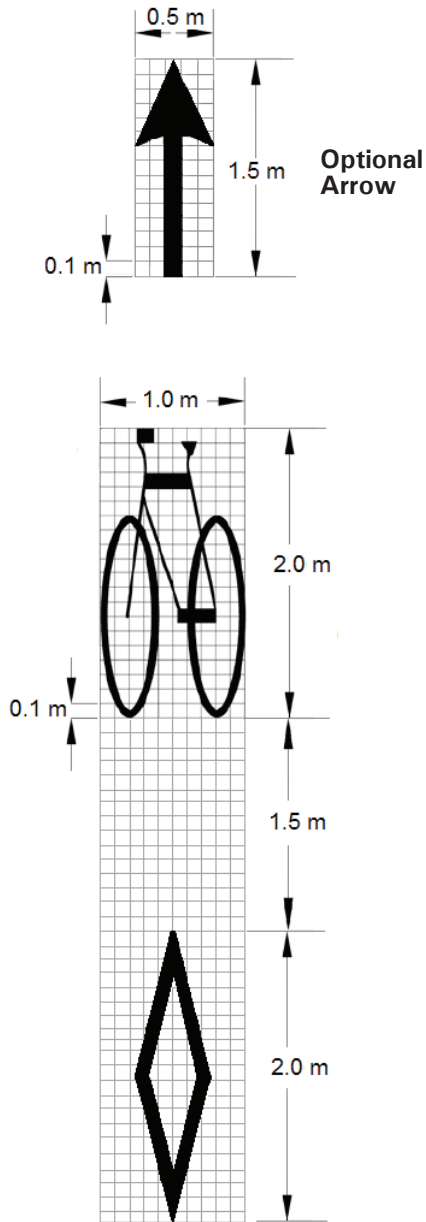

Source: Based on the TAC Bikeway Traffic Control Guidelines for Canada, 2012 (Table 7-1)

Figure 4.60 – Solid White Bicycle Lane Line



Source: TAC Bikeway Traffic Control Guidelines for Canada, 2012 (Table 7-1)

Although white is the standard colour for edge lines, other colours are permitted for branding purposes, such as the example shown in **Figure 4.61**.

Diagonal hatched lines may be applied between the longitudinal white lines that define the buffer area. The spacing between the diagonal lines is typically in the range of 3 to 12 metres and is generally a function of vehicular speed. On roadways with faster moving motor vehicles, the lines may be spaced farther apart; on roadways with slower moving motor vehicles, the hatched lines should occur more frequently. Diagonal hatched lines are optional for a bicycle lane separated by a physical barrier such as a line of planters.

Where a separated bicycle lane contains a conflict zone and vehicles may pass onto the bicycle lane, the buffer should be discontinued and a dashed white bicycle lane, shown in **Figure 4.62**, should extend from the line which defines the boundary between the buffer and the travel lane.

Figure 4.61 – An Example of a Separated Bicycle Lane, Toronto



Credit: MMM, 2012

Figure 4.62 – Dashed White Bicycle Lane Line

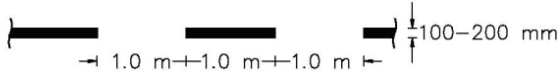

Source: TAC Bikeway Traffic Control Guidelines for Canada, 2012 (Table 7-1)

4.2.2.4 Design Applications

Separated Bicycle Lanes at Intersections

Separated bicycle lanes are located on the right-side of the motor vehicle lanes adjacent to the curb. The recommended treatment at an intersection consists of an advanced stop bar for cyclists to position themselves ahead of motorists during a red signal indication. This makes cyclists more visible to right-turning vehicles. **Figure 4.63** depicts a typical treatment, which includes two-stage left turn queue boxes as described on the next page.

As with conventional bicycle lanes, the designer should consider whether the characteristics of a site warrant the application of pavement markings or green surface treatment through the intersection. This serves to highlight conflict areas where cyclists and motor vehicles will cross paths so that each user group is more aware of the other.

The available treatment options in increasing order of visibility are:

- no treatment;
- bike stencils or chevrons at 1.5 m to 10 m spacing (with optional directional arrows to clarify cyclists' trajectories);
- sharrows at 1.5 m to 15 m spacing;
- dashed guide lines (with optional bike stencils or chevrons but not sharrows);
- green surface treatment; or
- dashed guide lines (with optional bike stencils or chevrons but not sharrows) and green surface treatment.

Elephant's feet markings are reserved for crossrides at intersections. They should not be used through the central portion of intersections themselves.

Municipalities should be consistent in whatever application they select for marking conventional bike lanes, separated bike lanes and raised cycle tracks through the intersection. This includes the option of no treatment.

Figure 4.63 – Separated Bicycle Lane with Barrier on Approach to Staggered Stop Bar

(See Table 4.4 for desired and suggested minimum widths for separated bicycle lanes. As an option, directional arrows may be applied within the bicycle lane)

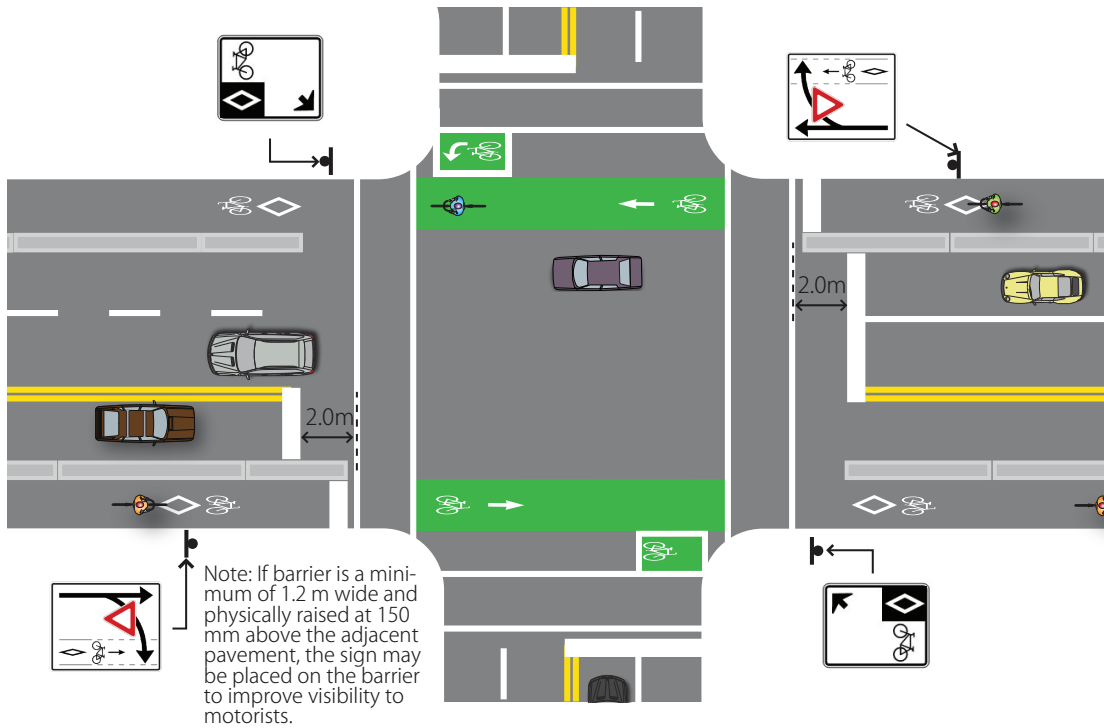

Source: MMM/ALTA, 2013

Two-Stage Left Turn Queue Box

Since cyclists are expected to stay within the separated bicycle lane on the approach to an intersection, cyclists intending to make a left-turn manoeuvre at an intersection have to complete this movement in two stages. A two-stage left turn queue box, as illustrated in **Figures 4.63, 4.64** and **4.65**, should be provided to allow the left-turn movement of cyclists from a separated bicycle lane into a cross-street. The queue box is a designated area within the signalized intersection, which is aligned with the cross-street on-road bicycle facility (if one is provided) and shadowed by a parking lane, buffer, crosswalk setback or on-road bicycle facility.

This designated space should be marked with a white rectangular or square box using 100 mm wide solid lines surrounding a turn arrow pointing in the direction in which cyclists will leave the intersection, plus a bicycle symbol oriented according to the direction from which they entered.

Cyclists waiting in the left turn queue box will be situated in front of the stop bar of the cross street. At this time the traffic signal indication for the cross street will be red. Given that cyclists in the queue box may obstruct the right turn movement from the cross street, designers should consider restricting this right turn on red.

The queue box concept permitting cyclists to wait in front of the stop bar is new in Ontario. In order to communicate the legitimacy of the facility to drivers and to give cyclists the confidence to place themselves in this location, green surface treatment should be used to enhance the visibility of the two-stage left turn queue box.

This facility may also be applied also for a conventional bicycle lane or a raised cycle track. Refer to **Section 4.2.1.4** for other design applications of left turn queue boxes.

Figure 4.64 – Two-Stage Left Turn Queue Box in Curb Area

(See Table 4.4. As an option, directional arrows may be applied within the bicycle lane, and right turns on red from the cross street may be restricted.)

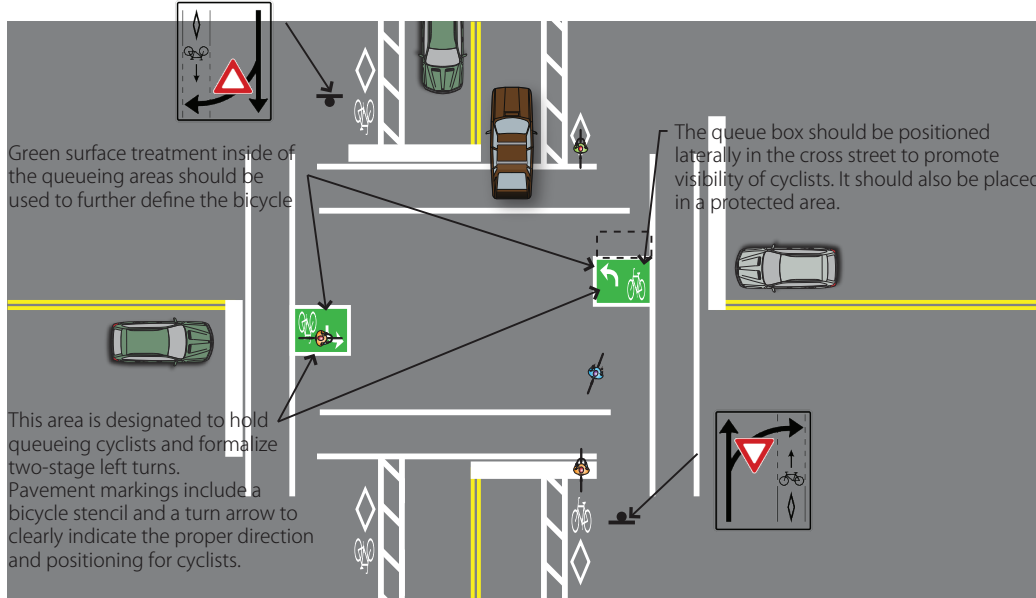

Source: MMM/ALTA, 2013

Figure 4.65 – Two-Stage Left Turn Queue Box With Parking Lane Adjacent to Buffered Bicycle Lane

(See Table 4.4. As an option, directional arrows may be applied within the bicycle lane, and right turns on red from the cross street may be restricted. For cases not involving a parking lane, refer to Figure 4.37)

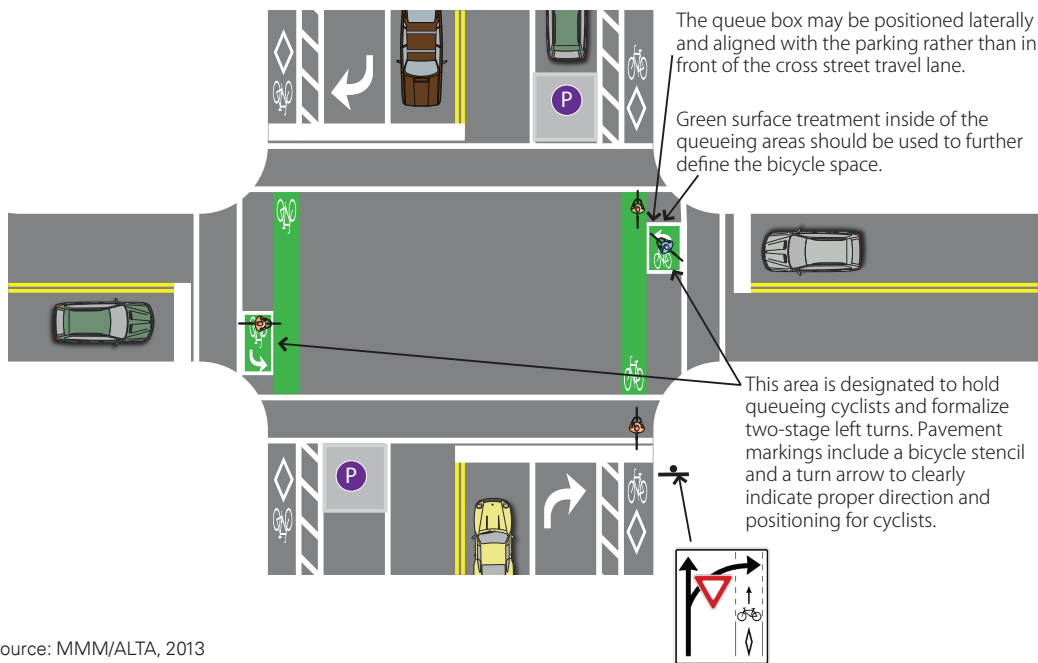

Source: MMM/ALTA, 2013

An alternative solution may be considered that does not require right turns on red from the cross street to be restricted. **Figure 4.66** depicts an example of a queue box located within the boulevard corner instead of within the intersection, with the sidewalk and pedestrian crosswalk set back from the intersection. A three to five second leading pedestrian and bicycle interval could also be considered such that both pedestrians and cyclists

may initiate their movement into the intersection ahead of the turning vehicles.

It is important to note that this innovative solution is yet to be implemented; therefore it is not currently a recommended practice but can be considered where the context is appropriate. Monitoring of the operations for this design application is recommended.

Figure 4.66 – An Example of a Context Specific Two-Stage Queue Box within the Boulevard

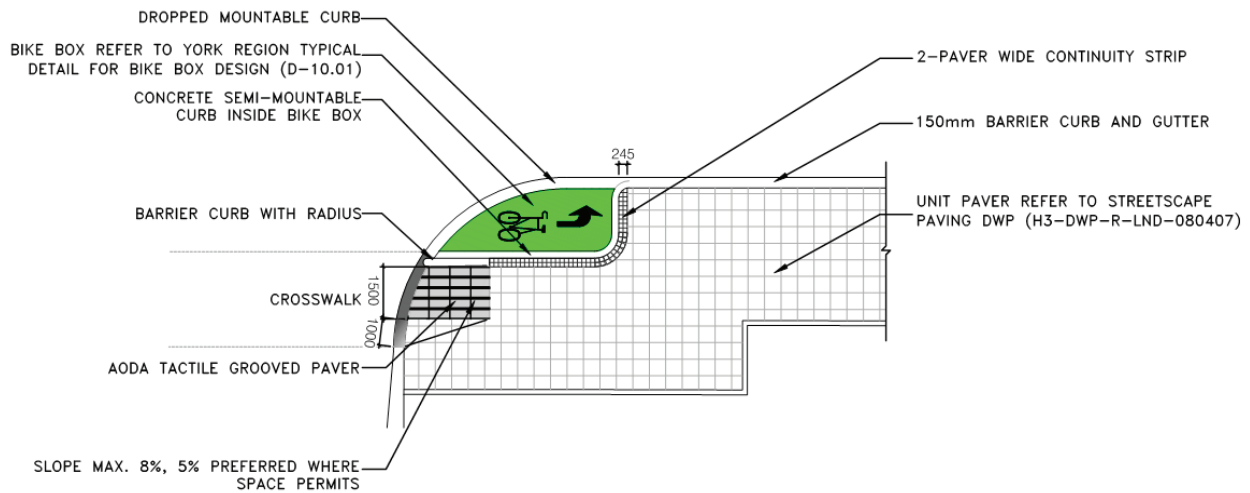

Source: York Region

4.2.3 Contraflow Bicycle Lanes

Contraflow bicycle lanes are used to enable two-way bicycle travel on a roadway that is designated as one-way for motor vehicles. A cyclist riding within a contraflow bicycle lane travels in the opposite direction to the motor vehicle traffic. Contraflow bicycle lanes may be applied to provide greater connectivity within a bikeway network where the route using non-contraflow bicycle lanes would be much longer. When planning and designing this facility type, consideration should be given to the number of intersecting driveways and streets on the side of the road with the contraflow bicycle lane. Furthermore, contraflow bicycle lanes may require the installation of bicycle signals. Practitioners should refer to **Section 5.8** and *OTM Book 12A* for guidance on signalization for bicycles.

4.2.3.1 Geometry

The geometry of the contraflow bicycle lane depends on the operating speed and traffic volume of the roadway, as well as the presence of on-street parking and available right-of-way for the roadway corridor. Contraflow bicycle lanes should be 2.0 metres wide to allow cyclists additional space to

manoeuvre around any obstacles or overtake other cyclists without crossing the directional dividing line. A buffer should be provided between the contraflow lane and any on-street parking alongside it. Where additional width is available (or in the unusual scenario of high oncoming vehicle speed or volume) a marked buffer may be provided to separate cyclists from opposing traffic or parked vehicles. Please refer to **Section 4.2.3.4** for guidance on positioning the contraflow bicycle lane.

Table 4.5 presents desired width and suggested minimum lane widths for contraflow bicycle lanes. Practitioners should always design to the desired width. However, through the use of sound engineering judgement, a practitioner may consider reducing the width to a value greater than or equal to the suggested minimum, but only for context specific situations on segments or corridors with constrained right-of-way widths. **Figure 4.67** includes several examples of contraflow bicycle lanes.

Practitioners should refer to **Section 4.2.1** for design details on the bicycle lane on the non-contraflow side of the street.

Table 4.5 - Desired and Suggested Minimum Widths for a Contraflow Bicycle Lane (to the face of curb)

Facility	Desired Width	Suggested Minimum
Contraflow Bicycle Lane	2.0 m	1.8 m ^a
Contraflow Bicycle Lane adjacent to on-street parking	2.0 m lane + 1.0 m buffer to parking	1.8 m ^b lane + 0.5 m ^c buffer to parking
<p>^aA width of 2.0m is recommended to allow cyclists to overtake one another within the contraflow lane. A buffer zone (desired width 1.0 m; suggested minimum 0.5 m) may be provided along the centre line where the speed or volume of oncoming vehicles is high.</p> <p>^bWhere the contraflow lane is proposed to be buffered by a concrete curb, median or planters, maintenance procedures and costs should be considered since small street sweeper vehicles typically require 2.0m of unobstructed running width. Designers should check the requirements for their municipality and factor in higher maintenance costs should their chosen facility widths require the use of specialized equipment or manual sweeping. See Section 8 for further information on maintenance considerations.</p> <p>^cAssumes a parking lane width of 2.5m, although where possible the buffer width should be increased by reallocating road space from the parking lane. This is to encourage motorists to park closer to the curb, thus reducing the conflict zone between cyclists and car doors that may open without warning. In a low volume, low speed constrained corridor, a minimum 1.8m wide bicycle lane may be provided without a buffer. However, the practitioner should consider the increased risk of collisions between cyclists and opening car doors or alighting passengers.</p>		

Figure 4.67 – Examples of Contraflow Bicycle Lanes



4.2.3.2 Signs

All signs used for contraflow bicycle lanes should be sized appropriately for interpretation by both motorists and cyclists, and should conform to the standards outlined in *OTM Book 5 – Regulatory Signs*.

Bicycles Excepted Tab Sign

The Bicycles Excepted tab sign shown in **Figure 4.68** should be attached below a Do Not Enter sign Rb-19 (OTM) that is located on a roadway with a contraflow bicycle lane. It should also be attached below a No Right Turn sign Rb-11 (OTM) or No Left Turn sign Rb-12 (OTM) that is located on the approach to a roadway with a contraflow bicycle lane. This sign indicates that cyclists may make the indicated manoeuvres that are otherwise prohibited for motor vehicles. Practitioners should refer to **Section 4.2.3.4** regarding the applications of this sign. Practitioners should also refer to *OTM Book 5 – Regulatory Signs* for information on the Do Not Enter Rb-19 (OTM), No Right Turn Rb-11 (OTM) and No Left Turn Rb-12 (OTM) signs.

Figure 4.68 – ‘Bicycles Excepted’ Tab Sign



Rb-17t (OTM)
(200 mm x 600 mm)

Reserved Bicycle Lane Signs

A Reserved Bicycle Lane sign must be used to designate an on-road lane for the exclusive use of cyclists. Practitioners should use the OTM signs shown in **Figure 4.69a** and **4.69b** or the signs found in the *TAC Bikeway Traffic Control Guidelines for Canada*, as illustrated in **Figure 4.70**. Where the bicycle lane is immediately adjacent to the curb, the ground-mounted version of the Reserved Bicycle Lane sign Rb-84A (OTM) or RB-91 (TAC) should be installed. Otherwise, the overhead mounted version of the Reserved Bicycle Lane sign Rb-84 (OTM) or RB-90 (TAC) should be installed on a cantilever and centred above the designated lane.

Where OTM signs are used, the standard Reserved Lane Ends tab sign (Rb-85t) in **Figure 4.69b** must be attached below the last Rb-84 or Rb-84A standard Reserved Bicycle Lane sign, and the Begins tab sign (Rb-84t) may be attached below the first Rb-84 or Rb-84A sign. If TAC signs are being used, the Reserved Bicycle Lane Ends sign RB-92 should be installed at the end of the reserved lane instead of the RB-90 or RB-91 sign.

The placement of this sign along a contraflow bicycle lane is shown for various design applications in **Section 4.2.3.4**. Additionally, the frequency of the reserved bicycle lane sign between intersections should be determined through engineering judgement based on the speed of bicycles and other traffic, plus the distances between intersections. The maximum spacing is 200 metres and the signs should be repeated after every intersection.

Oversized versions of the Reserved Bicycle Lane sign and tab signs may be used in areas where traffic conditions warrant greater visibility. Practitioners should refer to OTM *Book 5 – Regulatory Signs* for details on this sign.

Figure 4.69a – Overhead and Ground-mounted Reserved Bicycle Lane Signs (OTM)

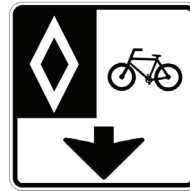

Rb-84 (OTM)
(600 mm x 600 mm)



Rb-84A (OTM)
(600 mm x 600 mm)

Figure 4.69b – Reserved Lane Begins and Ends Tab Signs (OTM)



Rb-84t (OTM)
(200 mm x 600 mm)



Rb-85t (OTM)
(200 mm x 600 mm)

Figure 4.70 – Reserved Bicycle Lane Signs (TAC)



RB-90 (TAC)
(600 mm x 750 mm)



RB-91 (TAC)
(600 mm x 750 mm)



RB-92 (TAC)
(600 mm x 750 mm)

Source: TAC Bikeway Traffic Control Guidelines for Canada, 2012 (Section 3.7.9, p. 24)

Contraflow Bicycle Lane Crossing Sign

The Contraflow Bicycle Lane Crossing sign WC-43 (TAC), shown in **Figure 4.71**, should be installed on the approach to an intersection with one-way motor vehicle movement and two-way cyclist movement.

Figure 4.71 – Contraflow Bicycle Lane Crossing Sign



WC-43 (TAC)
(600 mm x 600 mm)

Source: TAC Bikeway Traffic Control Guidelines for Canada, 2012 (Section 4.6.6, p. 39)

4.2.3.3 Pavement Markings

Contraflow bicycle lanes should be delineated by using a 200 millimetre solid yellow line, shown in **Figure 4.72**, between the contraflow bicycle lane and the motor vehicle lane, and are marked by two white symbols: a diamond and a bicycle. The diamond symbol should be centred in the bicycle lane and should have a stroke width of at least 75 millimetres. A directional arrow should be used for contraflow bicycle lanes to provide additional guidance to both cyclists and motorists. The cyclist directional arrow is shown with the bicycle symbol and diamond symbol in **Figure 4.73**.

A designated buffer space may be applied to separate the bicycle lane from the adjacent motor vehicle lane. Physical barriers, such as flexible bollards, may be placed within this buffer space to provide added separation between motorists and cyclists. The buffer for a contraflow bicycle lane consists of two 200 millimetre solid yellow lines spaced at least 0.5 metres apart, with optional diagonal hatched lines.

Diagonal hatched lines are typically applied for a bicycle lane separated by a marked buffer. The spacing between the diagonal hatches is generally a function of vehicular speed. On roadways with faster moving motor vehicles, the hatched lines should be spaced farther apart. On roadways with slower moving motor vehicles, the hatched lines should occur more frequently. Diagonal hatched lines are optional for a bicycle lane separated by a physical barrier.

Figure 4.72 – Yellow Contraflow Lane Line



Source: TAC Bikeway Traffic Control Guidelines for Canada, 2012 (Table 7-1)

Figure 4.73 – Bicycle Lane Pavement Markings

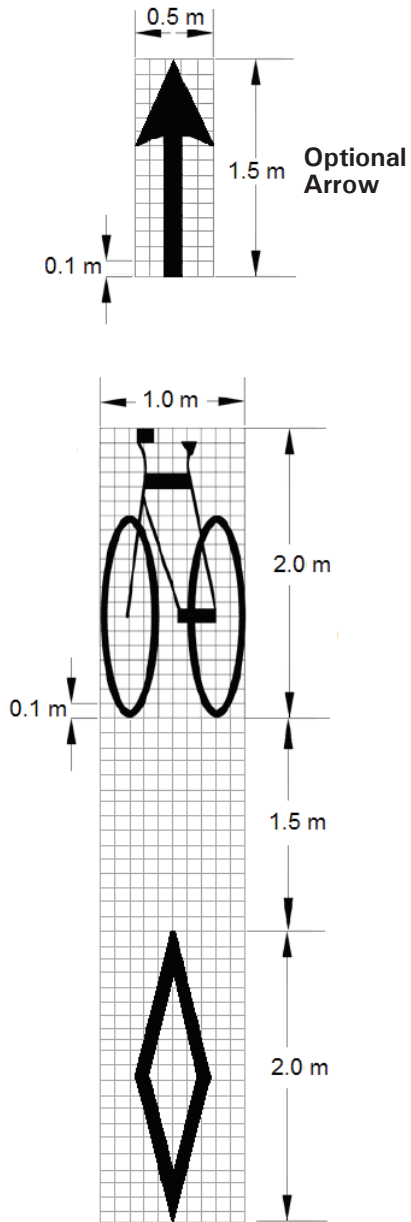

Source: Based on the TAC Bikeway Traffic Control Guidelines for Canada, 2012 (Table 7-1)

4.2.3.4 Design Applications

Figure 4.74 illustrates the typical plan view of a contraflow bicycle lane located on the side of the roadway without on-street parking. On roadways with on-street parking on one side of the street, the parking should be located on the non-contraflow side of the road. If this is not possible, or where a roadway has on-street parking on both sides of the street, the contraflow bicycle lane may be located between the parking lane and the curb, as illustrated in **Figure 4.75**. In cases where there is a high risk of debris accumulation, due to overhanging deciduous trees for example, and motor vehicle volumes are low, the contraflow bicycle lane may be situated between the directional dividing line and the on-street parking.

One Way Rb-21 (OTM), No Entry Rb-19 (OTM) and Turn Prohibition Rb-11 or Rb-12 (OTM) signs should be provided as shown in the figures, with a Bicycles Excepted tab below each sign. However, the application of signage and pavement markings should reflect context specific location and design conditions.

The optional provision of a bike lane in the non-contraflow direction is based on traffic volumes and speeds in that direction. On low volume streets, sharrows may be appropriate, or no markings at all. Practitioners should refer to **Section 4.2.1** for the design of the bicycle lane on the non-contraflow side of the road.

Figure 4.74 – Contraflow Bicycle Lane (on-street parking on one side of the road)

(A with-flow bicycle lane is optional, depending on motor vehicle speed and volumes. A buffer is recommended where conventional and contraflow bike lanes are adjacent to on-street parking.

See Tables 4.3 & 4.5. Directional arrows should be applied within the bicycle lane. Signs not directly related to the bicycle facility, such as stop signs, have been omitted for clarity.)

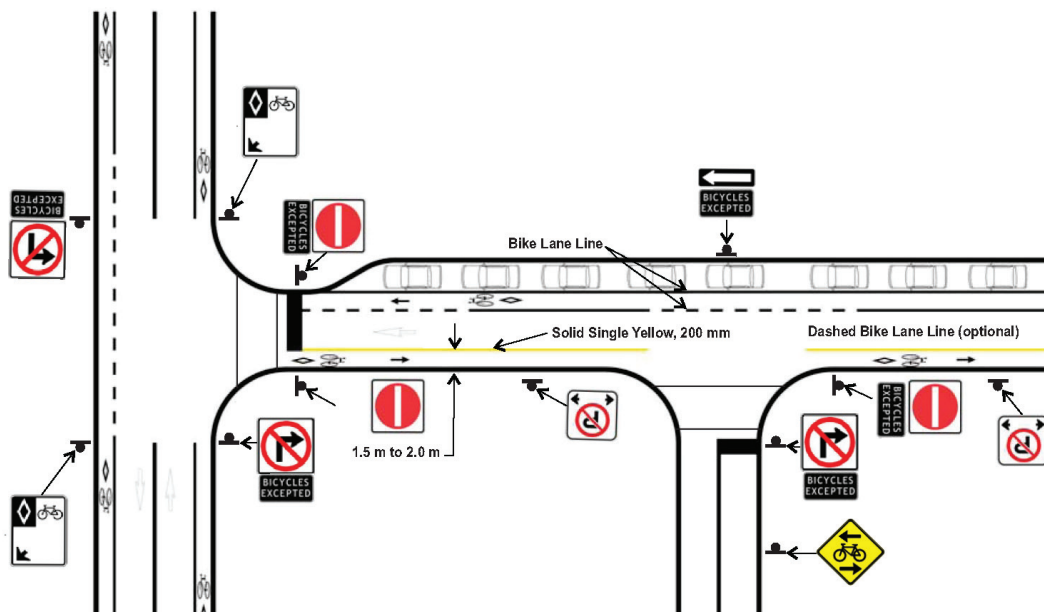

Source: Based on the TAC Bikeway Traffic Control Guidelines for Canada, 2012 (Figure 25, p. 81)

Figure 4.75 – Contraflow Bicycle Lane (on-street parking on both sides of the road)

(A with-flow bicycle lane is optional, depending on motor vehicle speed and volumes. A buffer is recommended where conventional and contraflow bike lanes are adjacent to on-street parking.)

See Tables 4.3 & 4.5. Directional arrows should be applied within the bicycle lane.
 Signs not directly related to the bicycle facility, such as stop signs, have been omitted for clarity.)

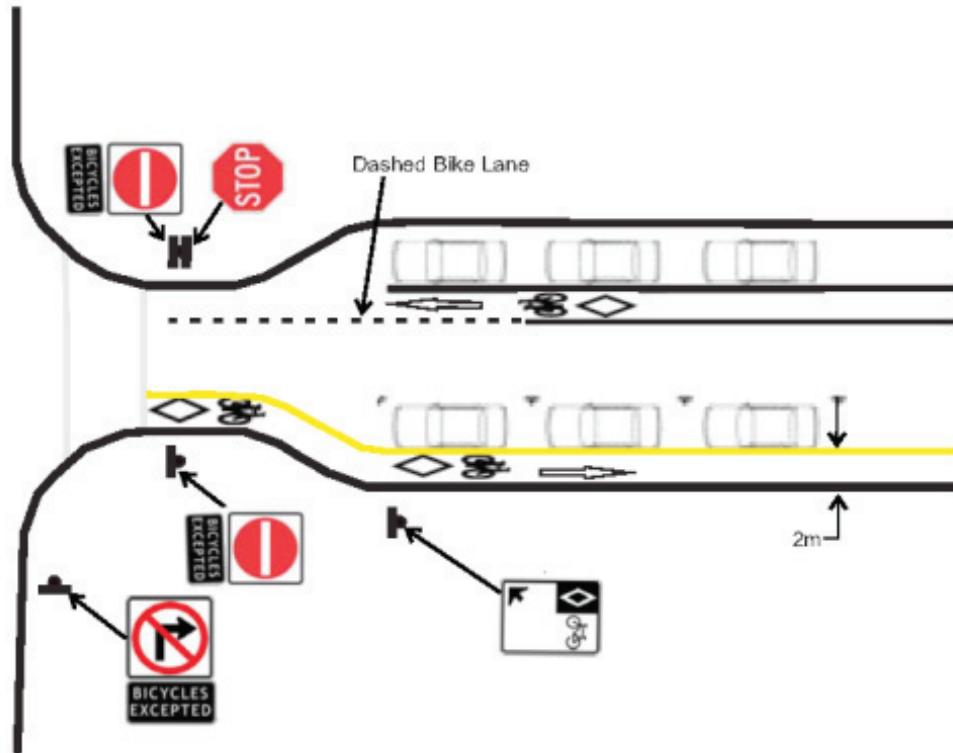

Source: Based on TAC Bikeway Traffic Control Guidelines for Canada, 2012 (Figure 26, p. 82)

4.3 Raised Cycle Tracks

4.3.1 One-way and Two-way Raised Cycle Tracks

A Raised Cycle Track is a bicycle facility adjacent to and vertically separated from the roadway. It is designated for exclusive use by cyclists and is distinct from the sidewalk. Raised cycle tracks can be one-way or two-way.

One-way raised cycle tracks should be provided for cyclists travelling in each direction to ensure continuity and connectivity. If this is not possible on the same street, then an alternate bicycle facility should be provided on a parallel street. One-way raised cycle tracks are vertically separated from the roadway by a rolled or barrier curb, and may be located within the boulevard of the roadway (refer to **Section 4.4.1**).

A two-way raised cycle track is located on one side of the roadway. In addition to being vertically separated, it may also be laterally separated by a physical barrier as described in **Section 4.2.2**.

When designing raised cycle tracks, a key consideration is the delineation of the raised cycle track relative to the sidewalk. Particular consideration should be given to persons with disabilities, especially those who are visually impaired.

Prior to initiating design work on a given link, practitioners should refer to the Bicycle Facility Type Selection process in **Section 3.2.2**. This will confirm whether the raised cycle track is the most suitable facility type and identify key design considerations.

4.3.1.1 Geometry

The width of a raised cycle track depends on the configuration of the facility (one-way or two-way), vehicle speed and volume, as well as available right-of-way. Desired widths are 2.0 metres for one-way raised cycle tracks and 4.0 metres if the facility is bidirectional.

Table 4.6 and **Figure 4.77** present the desired and suggested minimum widths for one-way and two-way raised cycle tracks. It is recommended that practitioners always design to the desired width. However, a practitioner through the use of sound engineering judgement may consider reducing the width to a value greater than or equal to the suggested minimum, but only for context specific situations on segments or corridors with constrained right-of-way widths.

Unlike unidirectional facilities, which should be provided on each side of the roadway, bidirectional facilities may be located on one side only. Compared to two unidirectional raised cycle tracks, bidirectional facilities may offer some savings in terms of installation cost. Restrictions associated with maintenance vehicle operating widths are also eliminated. However, transitioning to shared traffic lanes or conventional bike lanes is more problematic, and they are incompatible with bike boxes.

The introduction of bidirectional facilities also leads to considerably greater conflicts with turning motor vehicles at intersections (see **Section 5.4.1.2**). Practitioners should consider the mitigation strategies outlined in that section.

Where a raised cycle track is located adjacent to a sidewalk, practitioners may consider delineating the separation between them with a boulevard strip or contrasting pavement material. Designers should give this careful consideration where the sidewalk

is frequented by children, dog walkers or other pedestrians who may stray beyond the edge of the sidewalk.

Designers may specify that rolled curbs be provided to separate the raised cycle track from the adjacent motor vehicle lane. These allow cyclists to make comfortable transitions between the two. However, there is an increased risk of motorists making the same manoeuvre, for example in parking lanes.

To afford cyclists more protection from this, barrier curbs with a vertical face may be specified. A 'splash strip' should be provided between the raised cycle track and the barrier curb. Splash

strips provide a buffer to keep cyclists away from the hazardous vertical drop-off at the curb face. They are also used to store plowed snow so that it does not obstruct the adjacent raised cycle track. A typical splash strip is 1.0 metres wide and is, therefore, too narrow to function as a sidewalk or other active transportation facility. However, in the aforementioned case of a barrier curb alongside a parking lane, this also acts as a buffer to reduce the risk of cyclists colliding with opening car doors and alighting passengers.

Examples of raised cycle tracks are depicted in **Figure 4.76**.

Table 4.6 – Desired and Suggested Minimum Widths for Raised Cycle Tracks (excluding curb to travel lane)^a

Facility	Desired Width	Suggested Minimum
One-Way Raised Cycle Track	2.0 m	1.5 m ^b
Two-Way Raised Cycle Track	4.0 m	3.0 m

^aWhere there is on-street parking alongside the raised cycle track, a minimum clearance of 1.0m should be provided between the raised cycle track and the face of the barrier curb. This is to reduce the risk of cyclists colliding with opening car doors and alighting passengers.

^bMaintenance procedures and costs should be considered since small street sweeper vehicles typically require 2.0m of unobstructed running width. Designers should check the requirements for their municipality and factor in higher maintenance costs should their chosen facility widths require the use of specialized equipment or manual sweeping. See Section 8 for further information on maintenance considerations.

Source: Based on information from AASHTO Guide for Planning, Design and Operation of Bicycle Facilities, 2012 and the NACTO Urban Bikeway Design Guide, 2011

Figure 4.76 – Examples of One-Way and Two-Way Raised Cycle Tracks

One-Way Raised Cycle Track, Guelph



Credit: MMM, 2011

One-Way Raised Cycle Track, Toronto



Credit: MMM, 2013

Two-Way Raised Cycle Track, Montreal



Credit: MMM, 2012

Figure 4.77 – Cross-Sections of One-way and Two-Way Raised Cycle Tracks

(See Table 4.6 for more details)

One-Way Raised Cycle Track

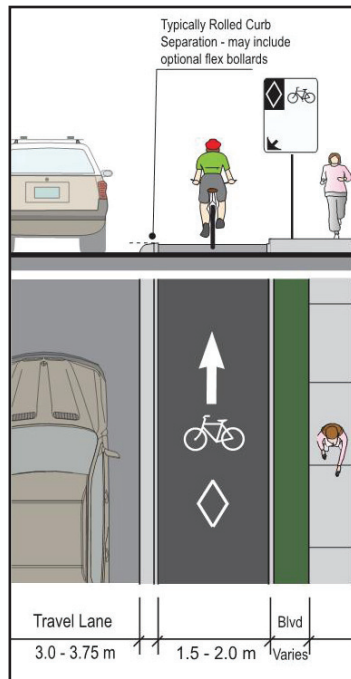

Source: MMM, 2013

Two-Way Raised Cycle Track

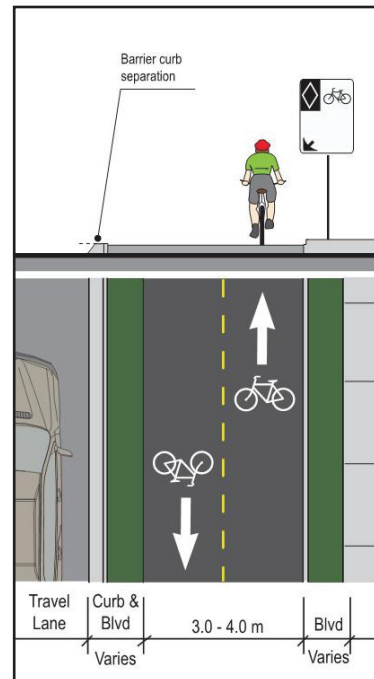

4.3.1.2 Signs

All signs used for raised cycle tracks should be sized appropriately for interpretation by both motorists and cyclists, and should conform to the standards outlined in OTM *Book 5 – Regulatory Signs* (March 2000) or TAC *Bikeway Traffic Control Guidelines for Canada – 2nd Edition* (January 2012) as indicated.

Reserved Bicycle Lane Signs

A Reserved Bicycle Lane sign must be used to designate an on-road lane for the exclusive use of cyclists. Practitioners should use the OTM signs shown in **Figure 4.78a** and **4.78b**. Alternatively, practitioners may choose to use the signs found in the TAC *Bikeway Traffic Control Guidelines for Canada*, as illustrated in **Figure 4.79**. Where the bicycle lane is immediately adjacent to the curb, the ground-mounted version of the Reserved Bicycle Lane sign Rb-84A (OTM) or RB-91 (TAC) should be installed. Otherwise, the overhead mounted version of the Reserved Bicycle Lane sign Rb-84 (OTM) or RB-90 (TAC) should be installed on a cantilever and centred above the designated lane.

Figure 4.78a – Overhead and Ground-mounted Reserved Bicycle Lane Signs (OTM)

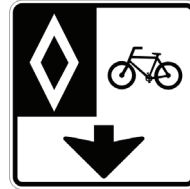

Rb-84 (OTM)
(600 mm x 600 mm)



Rb-84A (OTM)
(600 mm x 600 mm)

Figure 4.78b – Reserved Lane Begins and Ends Tab Signs (OTM)



Rb-84t (OTM)
(200 mm x 600 mm)



Rb-85t (OTM)
(200 mm x 600 mm)

Figure 4.79 – Reserved Bicycle Lane Signs (TAC)



RB-90 (TAC)
(600 mm x 750 mm)



RB-91 (TAC)
(600 mm x 750 mm)



RB-92 (TAC)
(600 mm x 750 mm)

Source: TAC *Bikeway Traffic Control Guidelines for Canada*, 2012 (Section 3.7.9, p. 24)

Where OTM signs are used, the standard Reserved Lane Ends tab sign (Rb-85t) in **Figure 4.78b** must be attached below the last Rb-84 or Rb-84A standard Reserved Bicycle Lane sign, and the Begins tab sign (Rb-84t) may be attached below the first Rb-84 or Rb-84A sign. If TAC signs are being used, the Reserved Bicycle Lane Ends sign RB-92 should be installed at the end of the reserved lane instead of the RB-90 or RB-91 sign.

The placement of this sign along a cycle track is discussed for various design applications in **Section 4.3.1.4**. Additionally, the frequency of the reserved bicycle lane sign between intersections should be determined through engineering judgement based on the speed of bicycles and other traffic, plus the distances between intersections. The maximum spacing is 20 metres, and the signs should be repeated after every intersection.

Bicycle Trail Crossing Side Street Sign

The Bicycle Trail Crossing Side Street sign WC-44 (TAC), shown in **Figure 4.80**, should be placed on the roadway at the approach to an intersection with a side street where a parallel raised cycle track crosses the side street close to the through road. The right or left version of the sign should be used as appropriate. If the left version is used, the sign should be installed on both sides of the road so that it is clearly visible to left-turning traffic. The Trail Crossing tab sign WC-44T (TAC), shown in **Figure 4.81**, may be attached below WC-44L or WC-44R (TAC) to convey the meaning of the sign.

Figure 4.80 – Bicycle Trail Crossing Side Street Sign

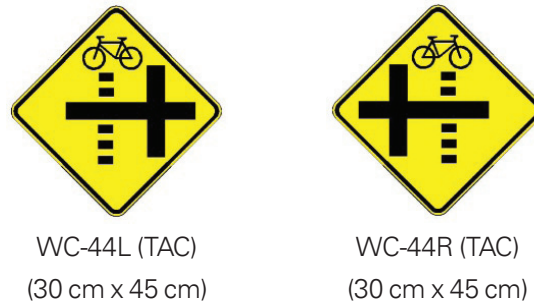

WC-44L (TAC)
(30 cm x 45 cm)

WC-44R (TAC)
(30 cm x 45 cm)

Source: TAC Bikeway Traffic Control Guidelines for Canada, 2012 (Section 4.6.5, p. 38)

Figure 4.81 – Trail Crossing Tab Sign



WC-44T (TAC)
(30 cm x 60 cm)

Source: TAC Bikeway Traffic Control Guidelines for Canada, 2012 (Section 4.6.5, p. 38)

Turning Vehicles Yield to Bicycles Signs

The Turning Vehicles Yield to Bicycles sign (Rb-37), illustrated in **Figure 4.82**, may be used at conflict zones where motorists turn across a bicycle facility and are required to yield to the cyclist. Where a raised cycle track transitions to a conventional bicycle lane on the approach to an intersection, as shown in **Figure 4.86**, this sign should be considered. The practitioner should also consider installing the sign at any driveways where the vertical separation of the raised cycle track has been reduced and there is a significant movement of right turning vehicles across the bicycle facility. The sign should incorporate the type of bicycle facility marking or treatment present in the conflict zone. In addition to or instead of the Turning Vehicles Yield to

Bicycles sign, practitioners may consider applying green surface treatment as described in **section 4.3.1.4**.

Figure 4.82 – Turning Vehicles Yield to Bicycles Sign

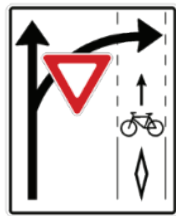

RB-37 (TAC)
(60 cm x 75 cm)

Source: TAC Bikeway Traffic Control Guidelines for Canada, 2012 (Section 3.2.3, p. 15)

4.3.1.3 Pavement Markings

Raised cycle tracks, which are raised and curb separated, are marked by a white diamond symbol, a white bicycle symbol and a directional arrow, which are depicted in **Figure 4.83**. The diamond symbol should be centred in the bicycle lane and should have a stroke width of at least 75 millimetres. Directional arrows are important in providing guidance to cyclists, particularly on two-way raised cycle tracks. These pavement markings must be used in conjunction with a Reserved Bicycle Lane sign as discussed in **Section 4.3.1.2**.

A one-way raised cycle track should be marked with a bicycle symbol, a diamond and an arrow to reinforce the direction of travel. This should be the same direction as for motor vehicle traffic in the adjacent lane.

A two-way raised cycle track should be marked with a directional arrow followed by a bicycle symbol and diamond for both directions of travel. In addition, a 100 millimetre yellow directional dividing

line should be placed in the centre of the two-way raised cycle track to separate bidirectional travel. This directional dividing line should be solid along segments with reduced sightlines and visibility in order to discourage passing manoeuvres. A broken (dashed) directional dividing line should be provided along segments where passing is permitted.

Figure 4.83 – Bicycle Lane Pavement Markings

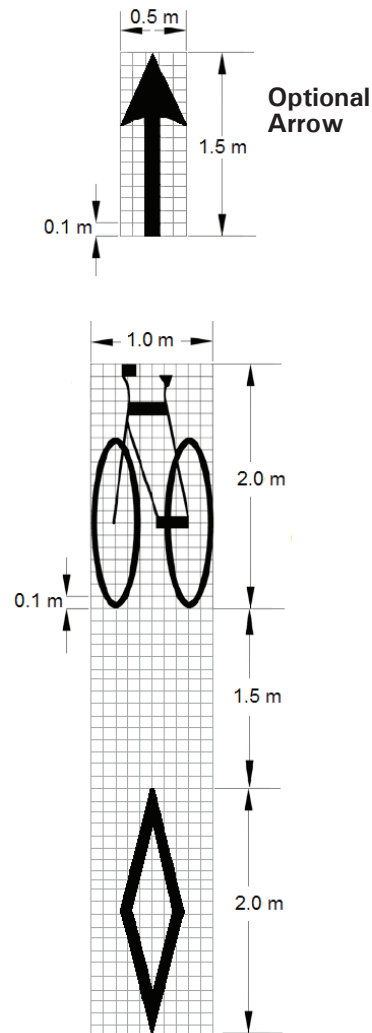

Source: Based on the TAC Bikeway Traffic Control Guidelines for Canada, 2012 (Section 7.4)

A solid white edge line, as shown in **Figure 4.84**, may be applied to raised cycle tracks that may be intermittently flush with the roadway at driveways along the route. Although white is the standard colour for edge lines, other colours are permitted for branding purposes, as with the example shown in **Figure 4.85**.

Figure 4.84 – Solid White Bicycle Lane Line



Source: TAC Bikeway Traffic Control Guidelines for Canada, 2012 (Table 7-1)

Figure 4.85 – Cycle Track Raised at Bus Stop, Toronto



Credit: MMM, 2012

4.3.1.4 Design Applications

Raised Cycle Tracks at Intersections

Practitioners may transition a one-way raised cycle track down a ramp to a conventional bicycle lane on the approach to an intersection as illustrated in **Figure 4.86**, and then transition back up a ramp to a raised cycle track following the intersection.

This design increases the visibility between right-turning motorists and through cyclists in advance of the conflict point. This may be appropriate for locations where cyclists on the raised cycle track are obscured from motorists by on-street parking. In that case, a triangular taper should be provided allowing a 10 to 15 metre gap between the end of the parking lane and the point at which cyclists will be alongside and parallel to the travel lane.

The ideal offset from this point to the stop bar will vary between sites. Practitioners should consider the configuration of the approach to the intersection, particularly sight lines, and the behaviour of drivers and cyclists. Consideration should also be given to cyclists who must merge with traffic to make a vehicular left turn. Designers may consider providing a two-stage left turn queue box or bike box to facilitate this movement. The layout for the queue box will be similar to that for separated bike lanes. Please refer to **Section 4.2.2.4** for more details.

Alternatively, practitioners may design the raised cycle track through the intersection as a crossside, as shown in **Figure 4.87**. A suggested minimum offset of 4.0 metres is recommended between the crossside and the travel lane. This means that turning motorists will approach the crossside at an angle that allows them good visibility of crossing cyclists. This design may require the side road stop bar to be set back. The impact of this on the visibility that motorists turning right from the side

road have of through traffic on the main road should also be considered. The adequacy of pedestrian storage at the intersection should also be reviewed, particularly where cyclist or pedestrian volumes are expected to be high.

Where the facility intersects the sidewalk, guidance should be provided on where cyclists should wait at the intersection. A white stop bar should be placed one metre from the sidewalk and should be accompanied by a “Cyclists Stop Here on Red Signal” sign, together with a cyclist pushbutton if the approach is actuated. A solid yellow centreline should extend 15 metres from the stop bar where a “SLOW Watch for Turning Vehicles” sign may be installed to warn cyclists approaching the intersection while a “Bicycle Crossing on Side Street” sign may be installed to warn motorists approaching the intersection.

A Yield to Pedestrians sign RB-39 (TAC), illustrated in **Figure 4.92**, may be installed to remind cyclists that they are approaching a pedestrian zone. Yield lines may be used in place of a stop bar to indicate the point at which bicycles are required to yield in compliance with a yield condition. Yield lines typically consist of a row of solid white isosceles triangles pointing toward approaching bicycle traffic extending across the approach to indicate the point at which the yield is intended or required to be made. The individual triangles comprising the yield line should have a base of 30 to 60 centimetres wide and a height equal to 1.5 times the base. The space between the triangles should be 5 to 30 centimetres.”

Practitioners should refer to **Sections 4.4.1.4** and **5.8.1** for more information on the design of crossrides.

Figure 4.86 – Raised Cycle Track Transition to a Conventional Bike Lane on the approach to an Intersection

(Design elements not to scale. Maximum slope of ramp between raised cycle track and bike lane is 1:8. Practitioners should consider providing a two-stage left turn queue box or bike box. Directional arrows should be applied within the raised cycle track)

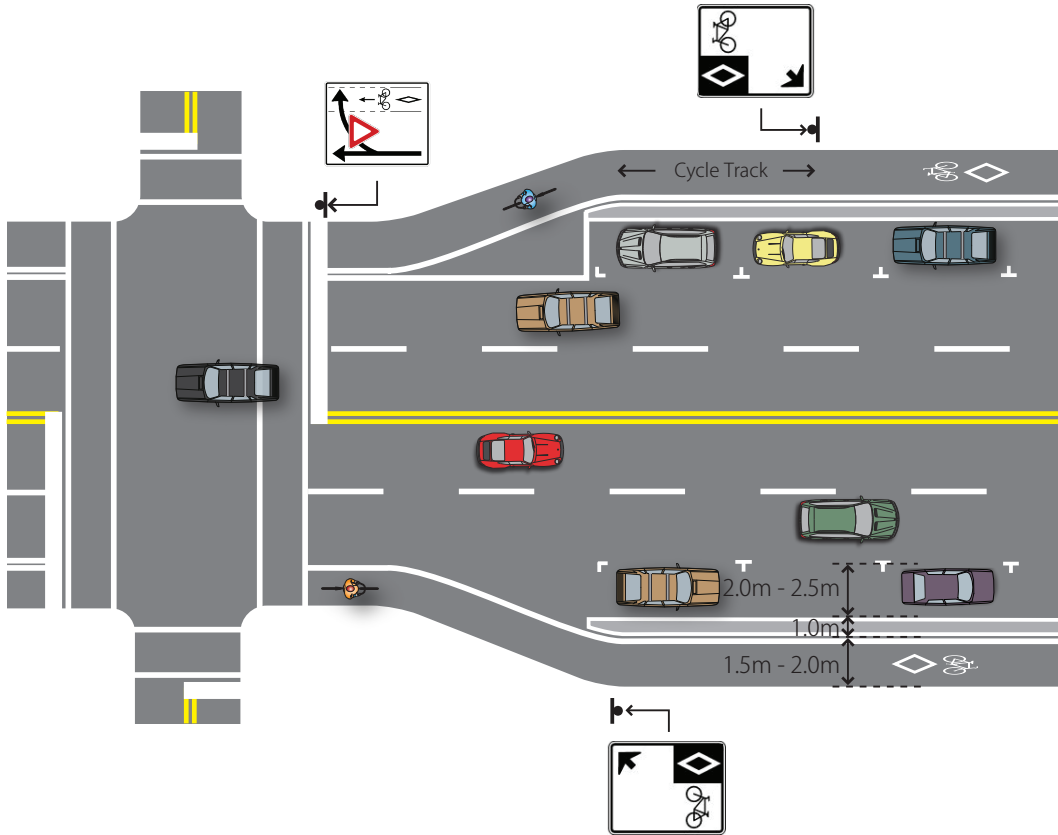

Source: Based on NACTO Urban Bikeway Design Guide

Figure 4.87 – Raised Cycle Track Carried Through an Intersection

(Directional arrows should be applied within the raised cycle track)

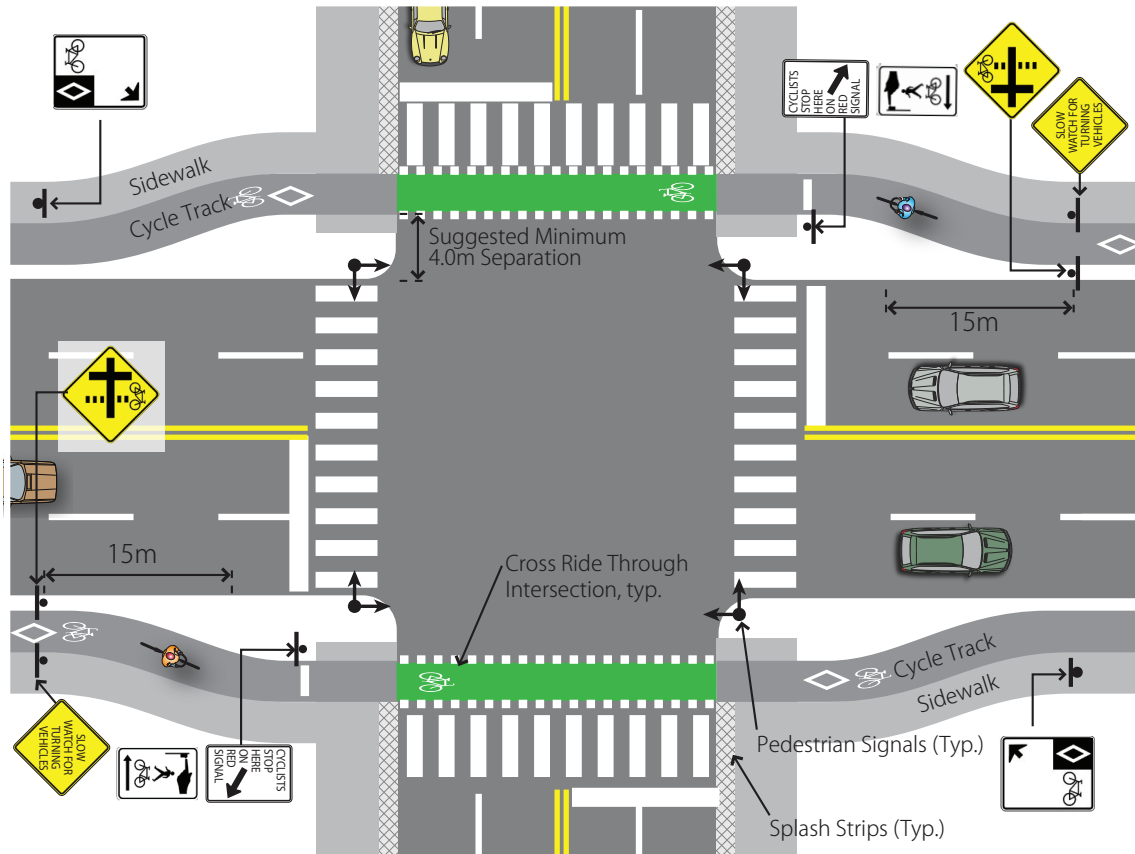

Source: MMM/ALTA, 2013

Considerations for Two-Way Raised Cycle Tracks at Intersections

Unlike the design shown in **Figure 4.86**, the layout shown in **Figure 4.87** may also be used to carry a bi-directional raised cycle track through an intersection. However, practitioners should

consider driver expectations at such locations, and take mitigating measures where appropriate. See **section 5.4.1.2** for further guidance.

4.4 In-Boulevard Facilities

4.4.1 In-Boulevard Bicycle Facilities and In-Boulevard Active Transportation Facilities

In-Boulevard Bicycle Facilities are separated from motor vehicle traffic by a boulevard or a verge within the roadway right-of-way. These are typically implemented adjacent to roadways with higher motor vehicle speeds and volumes along key cycling corridors. An in-boulevard facility can be constructed with the bicycle path distinct from the sidewalk or with a single facility shared by cyclists and pedestrians. In the former case, the in-boulevard facility may transition to a raised cycle track that is immediately adjacent to the curb, as described in **Section 4.3.1**. Examples of in-boulevard facilities are depicted in **Figure 4.88**.

Prior to initiating design work on a given link, practitioners should refer to the Bicycle Facility Type Selection process in **Section 3.2.2**. This will confirm whether the in-boulevard bicycle facility is the most suitable and identify key design considerations.

4.4.1.1 Geometry

In-boulevard facilities are located outside the travelled portion of the roadway and do

not necessarily follow its geometric design. Practitioners should consider several geometric elements including the width, design speed, grade, stopping sight distance, horizontal curvature, crest vertical curves and lateral clear zones.

One- and two-way in-boulevard bicycle facilities should be 2.0 metres or 4.0 metres wide respectively. **Table 4.7** presents the desired and minimum widths for in-boulevard bicycle facilities, and **Figure 4.89** illustrates typical cross sections. It is recommended that practitioners always design to the desired width. However, through the use of sound engineering judgement, a practitioner may consider reducing the width to a value greater than or equal to the suggested minimum, but only for context specific situations on segments or corridors with constrained right-of-way widths.

In addition, a ‘splash strip’ should be provided between the in-boulevard facility and the curb. Splash strips provide a buffer to keep cyclists and other users away from the hazardous vertical drop-off at the curb face. They are also used to store plowed snow so that it does not obstruct the adjacent in-boulevard facility. A typical splash strip is 1.0 metres wide and is, therefore, too narrow to function as a sidewalk or other active transportation facility.

Table 4.7 – Desired and Suggested Minimum Widths for In-Boulevard Bicycle Facilities^a

Facility	Desired Width	Suggested Minimum
One-Way In-Boulevard Bicycle Facility	2.0 m	1.8 m
Two-Way In-Boulevard Bicycle Facility	4.0 m	3.0 m ^b
Two-Way In-Boulevard Shared Facility	4.0 m	3.0 m ^b
^a Excludes splash strip (typical width 1.0 metre) where the in-boulevard facility abuts the curb.		
^b This may be reduced to 2.4 metres over very short distances in order to avoid utility poles or other infrastructure that may be costly to relocate.		

Source: Based on AASHTO Guide for Planning, Design and Operation of Bicycle Facilities, 2012; NACTO Urban Bikeway Design Guide, 2011

Figure 4.88 – Examples of In-Boulevard Facilities

(As an option, directional arrows may be applied within the in-boulevard facility)

One-Way In-Boulevard Bicycle Facility (Brampton)

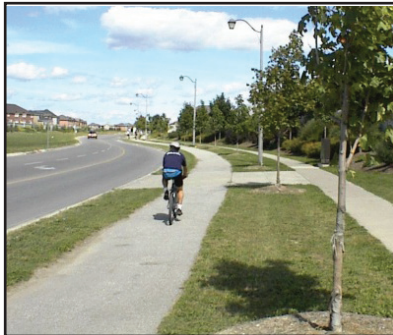

Credit: MMM, 2013

Two-way In-Boulevard Bicycle Facility (Toronto)



Credit: City of Toronto

Two-way In-Boulevard Shared-Use Facility (Mississauga)



Credit: MMM, 2013

Figure 4.89 – Cross-Sections of In-Boulevard Facilities

(See Table 4.7 for more details. As an option, directional arrows may be applied within the in-boulevard facility.)

One-Way In-Boulevard Bicycle Facility

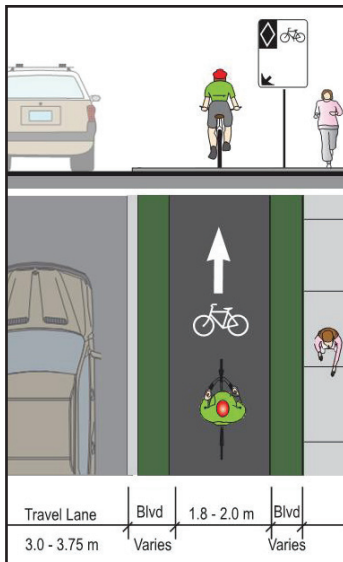

Source: MMM, 2013

Two-way In-Boulevard Bicycle Facility

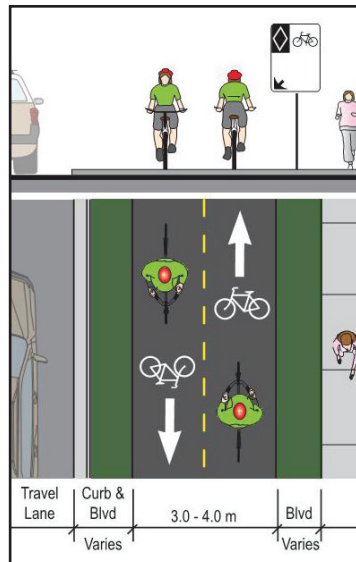

Two-way In-Boulevard Shared-Use Facility

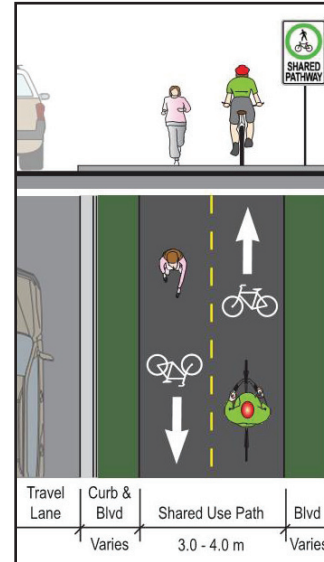

4.4.1.2 Signs

This section focuses on the signs used where the in-boulevard facility crosses a roadway. Signs that are only intended for cyclists and other active transportation users may have a reduced size. Otherwise, signs should be sized appropriately for interpretation by both motorists and cyclists.

Since cyclists may deviate slightly from the paved area, all signs should be mounted with a minimum clearance of 2.5m between the pavement surface and the lower edge of the sign. This is equivalent to the height of the cyclist's operating space and is to provide sufficient headroom for cyclists to pass them safely.

Practitioners should reference the standards in the TAC *Bikeway Traffic Control Guidelines for Canada – 2nd Edition* (January 2012) for further guidance on signs for in-boulevard facilities.

Shared Pathway Sign

The Shared Pathway sign Rb-71 (OTM), shown in **Figure 4.90**, should be installed along in-boulevard shared-use active transportation facilities to indicate that users are expected to share the space on the path. It should be placed on the far side of intersections and other decision points.

Figure 4.90 – Shared Pathway Sign



Rb-71 (OTM)
(300 mm x 450 mm)

Pathway Organization Sign

Within in-boulevard shared-use active transportation facilities, segregation of cyclists and pedestrians should be avoided where possible. Instead, a directional dividing line may be marked on the pathway, thus allowing it to operate as a “miniature roadway”. This relies on users obeying the basic premise that slower moving pedestrians and cyclists should keep right, and faster moving path users should pass on the left. However, the Pathway Organization Sign Rb-72a or Rb-72b (OTM) , shown in **Figure 4.91**, may be used on the approach to intersections where there is delineation between the pedestrian and cyclist space within a crossside. An example of this treatment is when an in-boulevard bicycle facility crosses a roadway parallel to a sidewalk and pedestrian crossing. Where pedestrians are directed to the left side of the crossing, Rb-72a (OTM) should be used. Where pedestrians are directed to the right side of the crossing, Rb-72b (OTM) should be used.

Figure 4.91 – Pathway Organization Sign



Rb - 72a (OTM)
(300 mm x 450 mm)



Rb - 72b (OTM)
(300 mm x 450 mm)

Yield to Pedestrians Sign

The Yield to Pedestrians sign Rb-73 (OTM) should be placed in advance of locations that are exclusively for pedestrians, for example at bus stops. This sign, shown in **Figure 4.92**, indicates to cyclists that they are required to yield to pedestrians in these areas.

Figure 4.92 – Yield to Pedestrians Sign



Rb-73 (OTM)
(300 mm x 450 mm)

Dismount and Walk Sign

The option of asking cyclists to dismount and walk their bikes should not be relied upon in lieu of adequately accommodating cyclists through appropriate road design. Being propelled by muscular power, cyclists more than any other vehicle operators will prefer to sustain their momentum and avoid stopping. Cyclists usually find it difficult to rationalize why “dismount and walk” restrictions are in place, and conclude that they were a poor, illogical or arbitrary decision. Thus, if facility designs cause cyclists to make what they consider to be unnecessary stops, this will increase the likelihood that they will ignore or disobey traffic controls.

Consequently, the Dismount and Walk sign Rb-70 (OTM), shown in **Figure 4.93** should be used only in exceptional cases, such as where an in-boulevard facility ends, and cyclists would discharge into a sidewalk or pedestrian zone.

Figure 4.93 – Dismount and Walk Sign



Rb-70 (OTM)
(300 mm x 300 mm)

Pedestrian and Bicycle Crossing Ahead Sign

The Pedestrian and Bicycle Crossing Ahead sign Wc-15 (OTM), shown in **Figure 4.94**, should be placed on the roadway at the approach to an in-boulevard facility. The right or left version of the sign should be used as appropriate such that the pedestrian and bicycle symbols are oriented towards the centre of the road. The Crossing tab sign Wc-32t (OTM), shown in **Figure 4.95** must be attached below Wc-15 (OTM) to convey the meaning of the sign.

Figure 4.94 – Pedestrian and Bicycle Crossing Ahead Sign



Wc-15 (OTM)
(600 mm x 600 mm)

Figure 4.95 – Pedestrian and Bicycle Crossing Tab Sign



Wc-32t (OTM)
(300 mm x 600 mm)

Figure 4.97 – Trail Crossing Tab Sign



WC-44T (TAC)
(300 mm x 600 mm)

Source: TAC Bikeway Traffic Control Guidelines for Canada, 2012 (Section 4.6.5, p. 34)

Bicycle Trail Crossing Side Street Sign

The Bicycle Trail Crossing Side Street sign WC-44 (TAC), shown in **Figure 4.96**, should be placed on the roadway at the approach to an intersection with a side street where a parallel in-boulevard facility crosses the side street close to the through road. The right or left version of the sign should be used as appropriate. If the left version is used, the sign should be installed on both sides of the road so that it is clearly visible to left-turning traffic. The Trail Crossing tab sign WC-44T (TAC), shown in **Figure 4.97**, may be attached below WC-44L or WC-44R (TAC) to convey the meaning of the sign.

Figure 4.96 – Bicycle Trail Crossing Side Street Sign



WC-44L (TAC)
(300 mm x 450 mm)



WC-44R (TAC)
(300 mm x 450 mm)

Source: TAC Bikeway Traffic Control Guidelines for Canada, 2012 (Section 4.6.5, p. 38)

4.4.1.3 Pavement Markings

In-boulevard bicycle facilities should be marked by a white bicycle symbol. A pedestrian symbol should also be used where pedestrians and other active transportation users are permitted to share the in-boulevard facility. Practitioners have the option of adding a white directional arrow to guide users on where to place themselves on bidirectional in-boulevard facilities.

A solid yellow 100-millimetre directional dividing line should be used on in-boulevard facilities with bidirectional bicycle or shared-use active transportation traffic where passing should be discouraged on horizontal or crest vertical curves with poor sightlines, and on the approach to intersections. A broken yellow 100-millimetre centre line is an optional treatment and may be provided where sightlines are good and passing is permitted. Some road authorities may choose not to use a centre line between intersections. **Figures 4.98** and **4.99** illustrate the typical pavement markings for in-boulevard facilities.

Where an in-boulevard facility crosses the roadway, practitioners should apply white elephant's feet pavement markings, as shown in **Figure 4.100**, to show the edge of the crossride. See **Section 5.8.1** for further guidance.

Figure 4.98 – Typical Pavement Markings for Two-Way In-Boulevard Shared Use Paths (Broken versus solid yellow centre line)

(Pavement stencils optional)

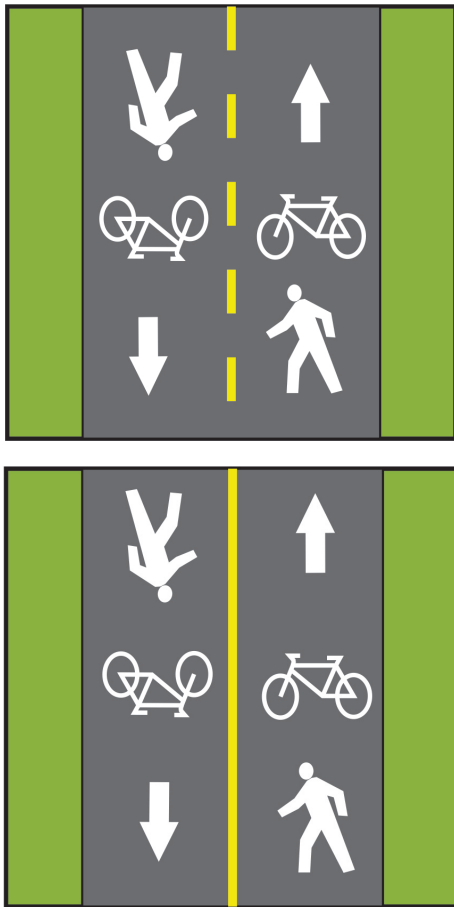

Source: MMM, 2013

Figure 4.99 – Bicycle Pavement Markings

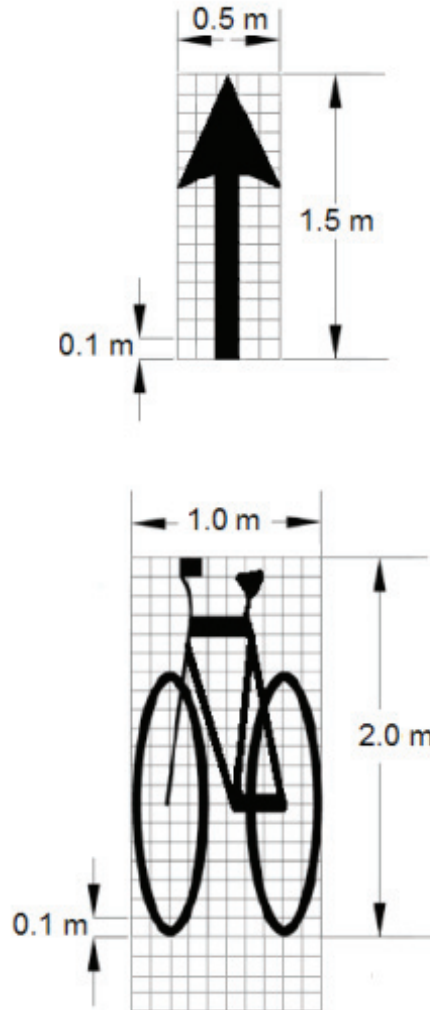

Source: TAC Bikeway Traffic Control Guidelines for Canada, 2012 (Table 7-1)

Figure 4.100 – Typical Elephant's Feet Pavement Markings for Crossrides

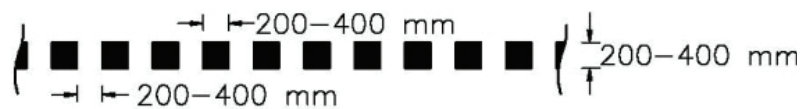

Source: TAC Bikeway Traffic Control Guidelines for Canada, 2012 (Table 7-1)

4.4.1.4 Design Application

Crossrides

At crosswalks, cyclists are required to dismount and cross as a pedestrian by walking their bicycle. Where a crossride is provided in place of a crosswalk, a cyclist may ride their bicycle within the crossing without dismounting.

Practitioners may provide a crossing with separate space for cyclists and pedestrians. Alternatively, the option exists to provide a combined crossing, with the cyclist crossing areas on each side of the pedestrian crossing. Where pedestrian and cyclist volumes are low, a reduced width mixed crossing may be proposed. This allows cyclists and pedestrians to mix, and for each to use the full width of the crossing, although cyclists must yield the right-of-way to pedestrians within the crossing.

Each of these crossing configurations may be used at both signalized and unsignalized intersections, although the mixed crossing is more frequently applicable in the latter case. Practitioners should refer to **section 5.8.1** or *OTM Book 12A* for details regarding bicycle signalization.

Proposed multi-use paths may cross major intersections where channelized right turns are currently present. This configuration consists of a small triangular island separating the through lanes from the right turn channel.

Although crossings over the through and left turn lanes are signalized, those between the sidewalk and the triangular islands are not. These may be signed to indicate to right-turning drivers that they should yield to pedestrians however, due to the speed of a vehicle's approach and confusion over who has priority, this is not always effective. Allowing bicycles to use these crossing points

would compound these safety issues; cyclists would occupy the limited storage space on the islands and would be at a greater risk of collision with right turning vehicles. In such cases, it is recommended that channelized right turns be removed. They should be replaced with dedicated or shared right turn lanes depending on the capacity and geometric constraints at the intersection.

Figures 4.101 to 4.103 show typical applications of the three types of crossride presented in **Section 5.8.1**. **Figure 4.101** illustrates the application of a signalized crossing with separate space for cyclists and pedestrians. It allows the cyclist to cross the intersection without having to ride with vehicular traffic. The optimal positioning of cyclists relative to pedestrians on a crossride is site specific. The practitioner may adjust markings according to the desire lines of each user group in order to minimize conflicts between them.

The appropriate Pathway Organization Sign Rb-72a or Rb-72b (OTM) may be used between the sidewalk and the in-boulevard bicycle facility in advance of the separated crossride. Where the facility intersects the sidewalk, guidance should be provided on where cyclists should wait at the intersection. A white stop bar should be placed 1.0 metres from the sidewalk, and should be accompanied by a "Cyclists Stop Here on Red Signal" sign plus a cyclist pushbutton if the crossing is actuated. A solid yellow directional dividing line should extend a minimum of 15 metres from the stop bar where a "SLOWWatch for Turning Vehicles" sign may be installed to warn cyclists approaching the intersection while a "Bicycle Crossing on Side Street" sign may be installed to warn motorists approaching the intersection. A Yield to Pedestrians sign Rb-73 (OTM) may also be installed to remind cyclists that they are approaching a pedestrian zone.

Figure 4.101 – Separate Pedestrian and Cyclist Crossride (Signalized Example)

(As an option, directional arrows may be applied within the in-boulevard facility)

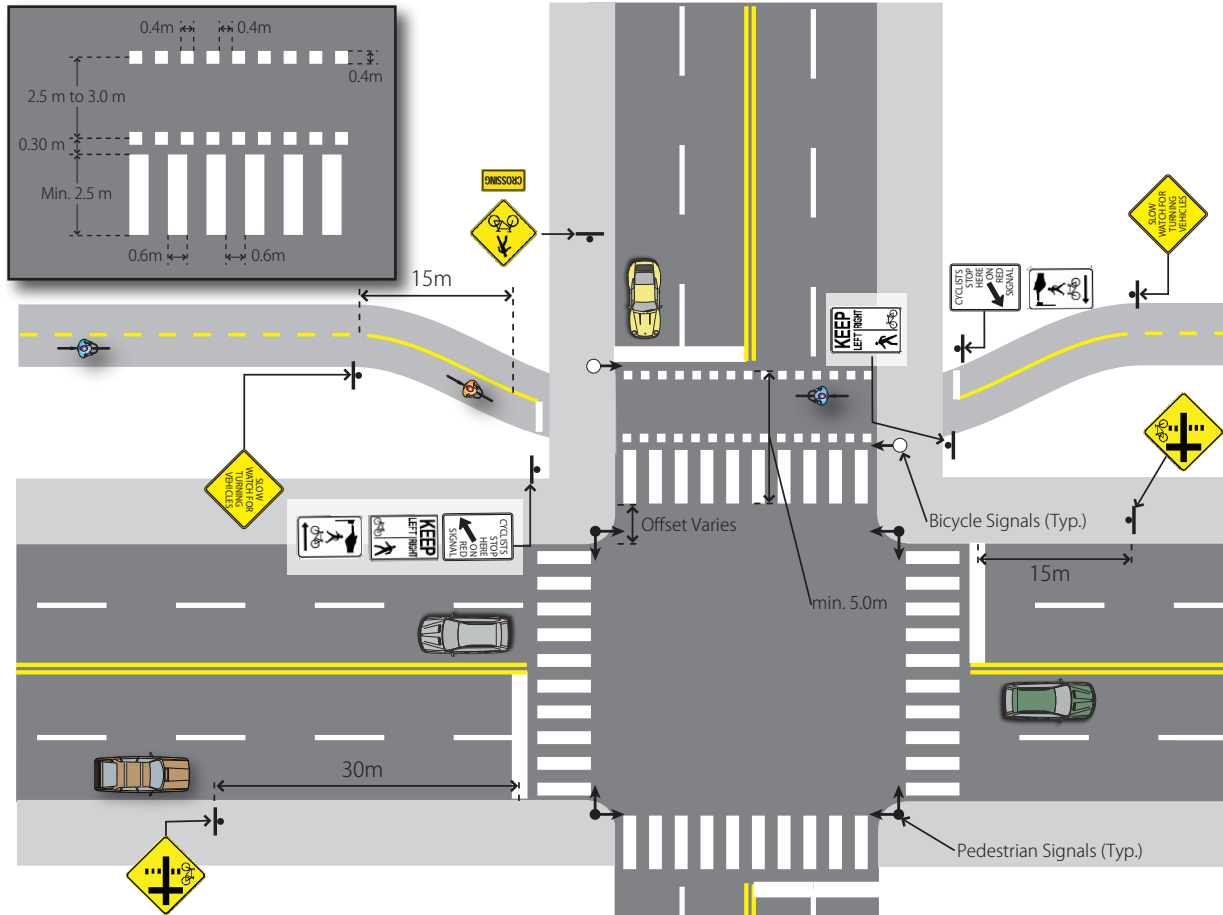

Source: MMM/ALTA, 2013

Figure 4.102 – Combined Pedestrian and Cyclist Crossside (Signalized Example)

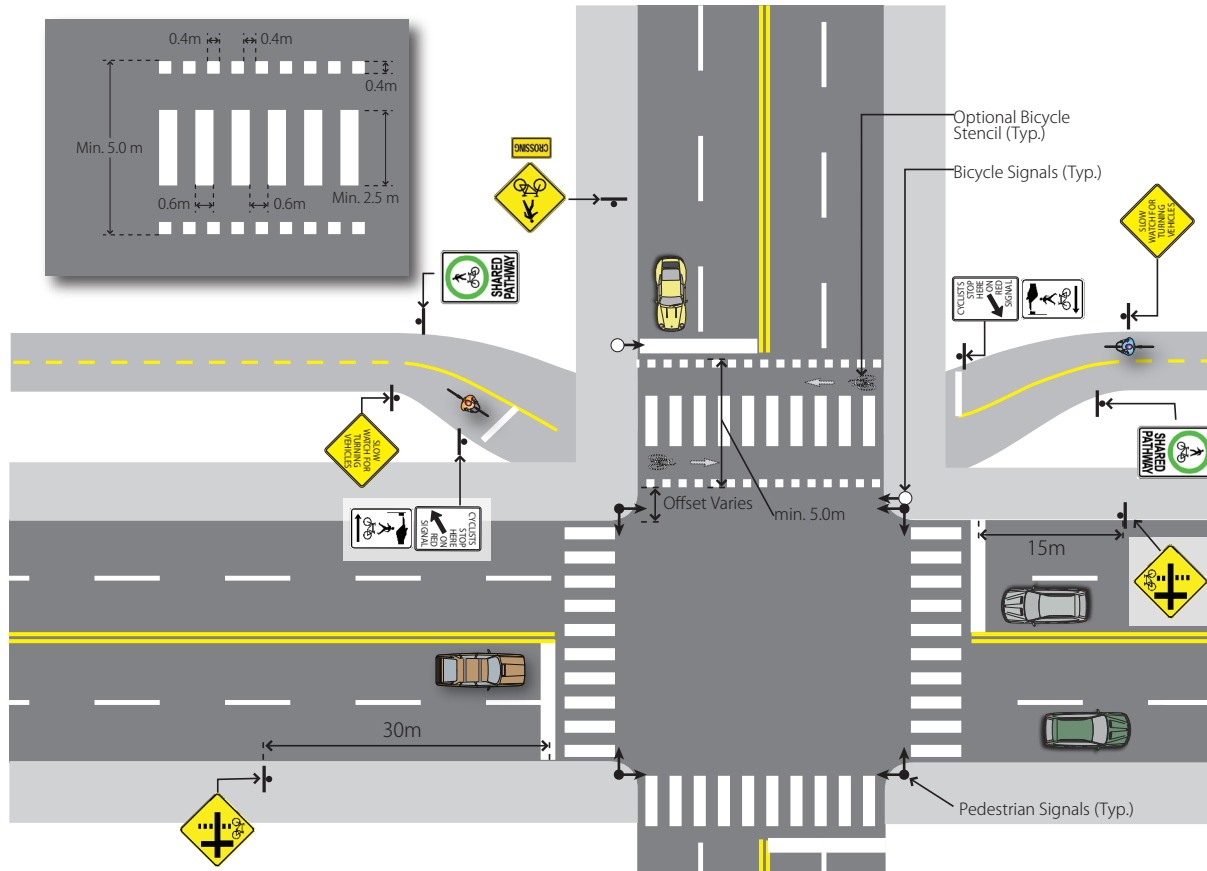

Source: MMM/ALTA, 2013

Figure 4.102 illustrates the recommended application of a signalized combined crossside in place of a crosswalk at an intersection. Elephant's feet pavement markings are placed on either side of the pedestrian zebra markings permitting both cyclists and pedestrians to use the same space for crossing the intersection. Cyclists are permitted to ride across the combined crossing, but are required to ride in between the elephant's feet and the zebra markings.

Where the facility intersects the sidewalk, guidance should be provided on where cyclists should wait at the intersection. A white stop bar should be

placed 1.0 metres from the sidewalk, and should be accompanied by a "Cyclists Stop Here on Red Signal" sign and a cyclist pushbutton if the crossing is actuated. A solid yellow centreline should extend 15 metres from the stop bar where a "SLOW Watch for Turning Vehicles" sign may be installed, while a "Bicycle Crossing on Side Street" sign may be installed to warn motorists approaching the intersection. A Yield to Pedestrians sign Rb-73 (OTM), illustrated in **Figure 4.92**, may also be installed to remind cyclists that they are approaching a pedestrian zone.

Figure 4.103 – Mixed Pedestrian and Cyclist Crossride (Unsignalized Example)

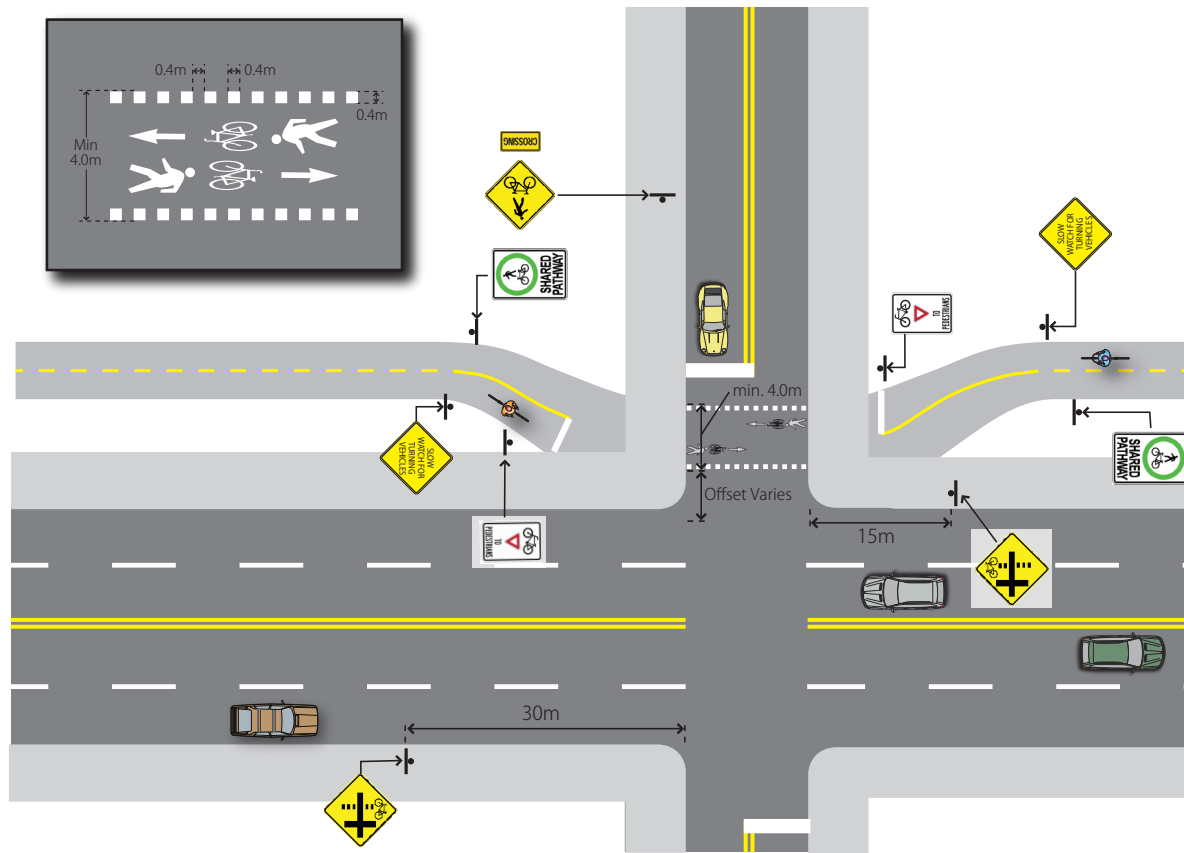

Source: MMM/ALTA, 2013

For low volume crossings, particularly at unsignalized locations where practitioners do not anticipate any queuing of pedestrians or cyclists, a mixed crossride may be implemented in place of a crosswalk, as shown in **Figure 4.103**. This allows cyclists and pedestrians to mix, and for each to use the full width of the crossing. The result is space-saving efficiencies where cyclist and pedestrian volumes are sufficiently low that each user can safely negotiate across the roadway without impeding another user.

The operation will be similar to that of a toucan crossing in the United Kingdom. The standard width for a toucan is 4.0 metres. Under constrained

site conditions and where cyclist and pedestrian volumes are very low, UK practitioners have reduced this to a minimum of 3.0 metres, however this has been the exception rather than the rule. This width may be considered in Ontario, but only under constrained or retrofit conditions and following an engineering review. As always, practitioners should fully document their rationale in case they are required to justify their decisions in the future.

The fact that the mixed crossride is narrower than the combined crossride may assist practitioners in retrofitting existing crosswalks to also be used by cyclists. However, the width of any existing crossing should not be used as the sole factor in determining

the width of the proposed facility. Practitioners should use their engineering judgement based on observations of pedestrians crossing and projected cyclist volumes. Following implementation, practitioners should regularly monitor sites where mixed crossrides have been implemented to ensure their safe operation. Mitigating steps, including widening or conversion to a separate or combined crossing should be taken where necessary.

Refer to **Section 5.8.1** regarding crossride types.

Transitions Between On-Road and Off-Road Facilities

A comprehensive cycling network will include both on-road and off-road facilities. To maximize network connectivity, cyclists should be able to transfer between facilities, however such transitions should be designed in a way that is clear and safe.

The most obvious feature of such a transition, yet one which is often overlooked, is a curb cut. The off-road facility should be flush with the pavement surface for the full width of the bicycle facility so cyclists can make a smooth transition.

Barrier curbs are difficult for cyclists to mount. Attempting this at speed may cause a cyclist to lose control and may result in wheel damage. Alternatively, cyclists may slow down on the approach; this behaviour may surprise drivers and trying to mount the curb may leave the cyclist exposed in the roadway, increasing the risk of a collision.

Cyclists may be tempted to use the curb cut provided for the nearest pedestrian facility, increasing the risk to pedestrians at a point that

is not designed to accommodate both groups. Practitioners are reminded that on designated shared use facilities such as multi-use paths, curb cuts are also required so as not to impede wheelchair users from accessing them.

Where cyclists are transferring to or from an off-road facility that runs parallel to the roadway, the dropped curb should be perpendicular to the cyclists' line of travel. This is to avoid twisting of the front wheel which may cause a cyclist to lose control. Good visibility between drivers and cyclists is paramount to safety. Transitions should not be placed near conflict points where motor vehicles may cross the path of a cyclist that has just entered an on-road facility. Although drivers may see a cyclist using the off-road facility prior to the transition, they may not be aware of the transition ahead and the impending conflict. The ideal transition will be similar to the one shown in **Figure 4.86** for raised cycle tracks.

Where cyclists are transferring to or from an off-road facility that runs perpendicular to the roadway, practitioners should consider providing a mid-block crossride as shown in **Figure 5.38**. This will enable cyclists to cross over without dismounting to reach the continuation of the off-road facility, where present. It will also assist cyclists turning left onto or off of an on-road facility. If there is no off-road facility designated for cyclists, the receiving area of the crossride should be designated as shared use, and a separate curb cut should be provided for cyclists to transition to the on-road facility.

In all cases, the designation of areas for cyclist use should be indicated by the signs for 'Shared Pathway' Rb-71 (OTM), 'Yield to Pedestrians' Rb-73 (OTM) and 'Dismount and Walk' Rb-70 (OTM) as shown in **Figures 4.90, 4.92 and 4.93** respectively.

At rural locations within a cycling network where two-way in-boulevard facilities meet one-way on-road facilities, designers should consider providing a jug-handle to assist cyclists in making that manoeuvre.

Figure 4.104 – Jug Handle Treatment at Rural T-intersection



Credit: City of Ottawa

It is not desirable for cyclists to have to merge into the travel lanes on an intersection approach, undertake a vehicular left turn, and then enter an in-boulevard facility on the corner of the intersection. The cyclist's placement and movement within the intersection will be different to that of a motor vehicle turning into the cross street. This may cause confusion to other road users and increase the likelihood of a collision. Also, cyclists accessing the in-boulevard facility from the intersection may do so at speed, limiting their ability to yield to pedestrians.

At T-intersections, designers may use the space available due to the absence of the fourth leg to install a jug handle. This allows cyclists to reorient themselves without mixing with general traffic, and then cross the road in a separate movement. The alignment of the jug handle should allow cyclists to easily cross the intersection and access the in-boulevard facility on the opposite side. An example of this is shown in **Figure 4.104**.

This is a situation where the formal adoption of crossride facilities in Ontario gives an opportunity

to clarify the traffic signal control provisions for cyclists. The existing crosswalk may be upgraded to a crossride so that cyclists may ride across on a green indication.

When deciding whether to provide a one-way or two-way crossride for cyclists, practitioners should consider which cyclist movements are supported by the facilities provided. Where a jug handle is at the point where the facility ends on that side of the road and continues in-boulevard across the road, the crossride should be one-way. This provides for cyclists who are crossing to enter the in-boulevard facility, but not for those exiting since there is no facility on the opposite side to receive them. Where a facility continues past the jug handle, a two-way crossride should be provided.

See **Section 4.2.1.4** for guidance on jug handles at urban intersections.

Section 5 – Additional Bicycle Facility Design Applications builds upon the information presented in this section. It discusses additional design considerations such as bicycle priority streets, traffic calming and integrating bicycle facilities as part of road retrofitting projects, as well as designing bicycle facilities at roundabouts, interchanges, ramp crossings, conflict zones, bridge structures and railway crossings.

5. Additional Bicycle Facility Design Applications

This section provides practitioners with additional information related to designing bicycle facilities. It builds upon **Section 4** and discusses context sensitive design applications related to bicycle priority streets, road retrofits, roundabouts, conflict zones, interchanges, railway crossings and grade separations, as well as other design considerations such as bicycle signals, lighting, fencing, drainage and temporary conditions. Practitioners should refer to **Section 2 – Bikeway Network Planning** for guidance on bikeway network planning and route selection as well as **Section 3 – Bicycle Facility Selection Tool** for guidance on selecting the appropriate bicycle facility type. Practitioners should also use this chapter in conjunction with the appropriate facility type discussed in **Section 4 – Bicycle Facility Design**.

Section 5.1 – Bicycle Priority Streets discusses the typical design elements to be included within a low volume, low speed street specifically designated for bicycle travel. This section also discusses design applications for streets with traffic calming.

Section 5.2 – Integrating Bicycle Facilities through Road Retrofits includes considerations for practitioners when implementing bicycle facilities on an existing roadway through reconstruction or through space reallocation.

Section 5.3 – Integrating Bicycle Facilities at Roundabouts includes information for the design of bicycle facilities at single and multi-lane roundabouts.

Section 5.4 – Conflict Zones includes information for optional pavement marking treatments wherever a cyclist may interact and have conflict with a motorist.

Section 5.5 – Integrating Bicycle Facilities at Interchanges and Ramp Crossings discusses various design applications for bicycle facilities at low-speed and high-speed ramp terminals.

Section 5.6 – Integrating Bicycle Facilities at Grade Separations discusses considerations for practitioners when implementing a bicycle facility on a bridge or tunnel to overcome a barrier such as a highway or watercourse.

Section 5.7 – Integrating Bicycle Facilities at Railway Crossings discusses various design applications where a bicycle facility crosses a railway track at a skewed angle.

Section 5.8 – Bicycle Signals discusses the signage and pavement marking treatments that should be applied where a bicycle facility contains a bicycle signal.

Section 5.9 – Other Design Considerations provides a brief overview of other design elements that may be included within a bicycle facility including drainage, fences, barriers and lighting.

Section 5.10 – Temporary Conditions discusses the signage treatments that may be considered when a bicycle facility is closed because of a temporary construction zone.

5.1 Bicycle Priority Streets

In some areas, particularly residential neighbourhoods, design treatments can be used to create ‘Bicycle Priority Streets’, which are often referred to as ‘Bicycle Boulevards’ or ‘Local Bicycle Streets’.

Bicycle Priority Streets are typically low-volume, low-speed streets that have been optimized for bicycle travel through treatments such as traffic calming, traffic reduction, signage, pavement markings and intersection crossing treatments. These treatments allow through movements for cyclists while discouraging similar through trips by non-local motorized traffic.

Figure 5.1 illustrates a variety of design elements which may be considered by practitioners when designing a bicycle boulevard. Some of the design elements, such as signage and pavement markings are already an integral part of on-road bicycle facilities such as signed bicycle routes and bicycle lanes. Practitioners should refer to the appropriate subsection within **Section 4** for design guidance. The other design elements discussed below are context sensitive and should be considered based on the unique set of site characteristics of the corridor.

Traffic Reduction on bicycle boulevards may be achieved through the implementation of culs-de-sac to restrict through motorized traffic while still providing through access for non-motorized traffic.

Intersection Treatments such as bike boxes, advanced stop bars, bicycle actuated signals, cross-rides and refuge islands can improve a cyclist’s ability to cross a major roadway more comfortably and safely.

Priority given to travel on Bicycle Boulevard through the use of pavement markings as well as stop and yield signs on intersecting roadways.

Traffic Calming measures such as roundabouts, speed tables, road diets and reduced speed limits aim to reduce the speed and volume of motor vehicle traffic on a particular roadway. However, consideration must be given to ensure traffic calming designs do not adversely affect cyclists (refer to **Section 5.1.1** for design guidance).

Figure 5.2 illustrates the implementation of these design elements within a typical Bicycle Priority Street.

Figure 5.1 – Bicycle Priority Street Design Elements

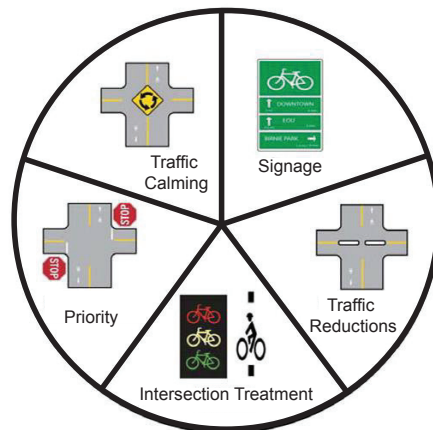

Source: IBPI Fundamentals of Bicycle Boulevard Planning & Design, 2009

Figure 5.2 – Design Elements on a Typical Bicycle Priority Street

(Signs not directly related to the bicycle facility, including some stop signs, have been omitted for clarity)

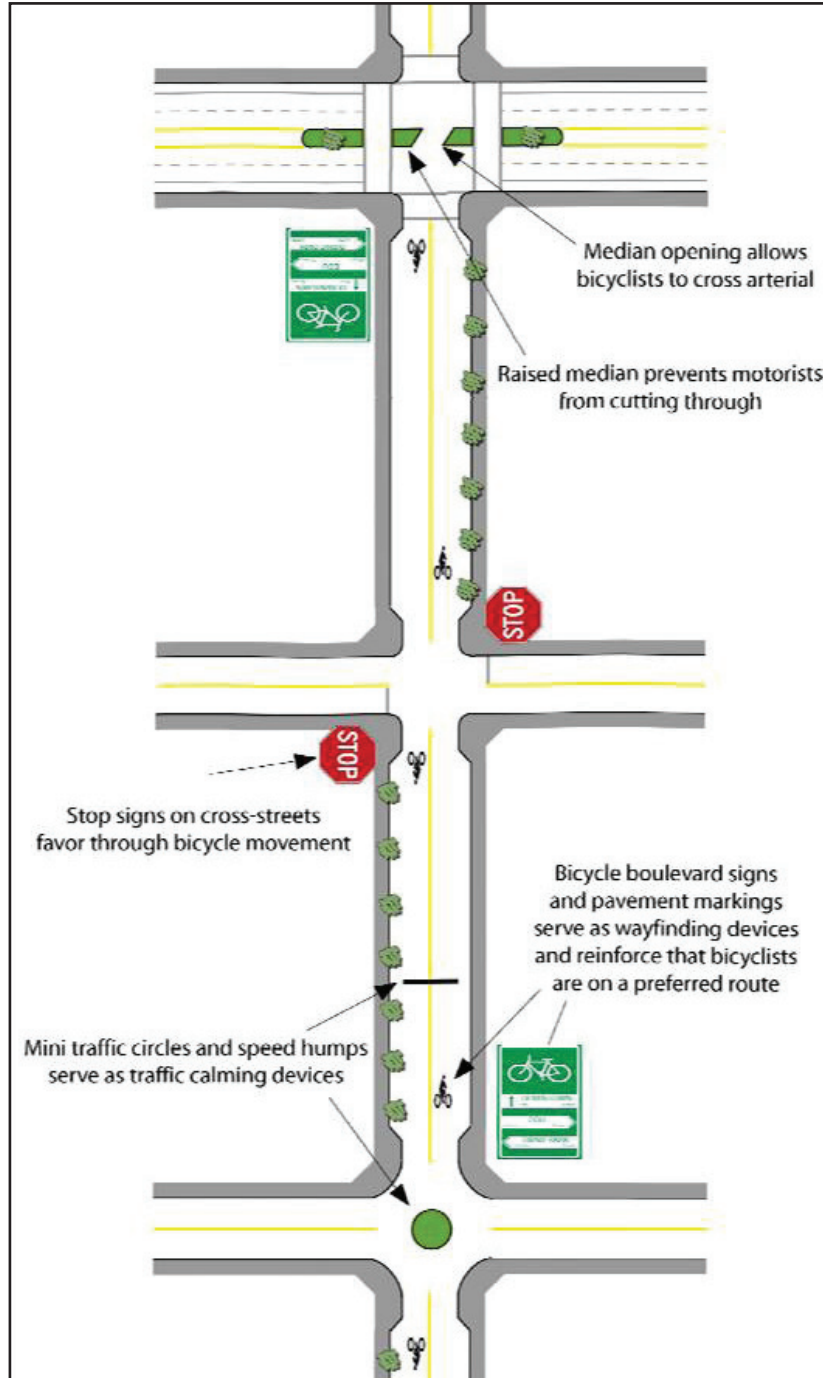

Source: IBPI Fundamentals of Bicycle Boulevard Planning & Design, 2009

5.1.1 Design Applications

Traffic calming devices are design features intended to reduce motor vehicle speeds and volumes. These devices include but are not limited to chicanes, speed humps, curb extensions and road diets. Traffic calming devices should be designed such that cyclist travel on roadways is not restricted.

Chicanes and Shared Roadways

Chicanes are a physical feature built into the roadway intended to reduce motor vehicle speeds. They are placed such that bump-outs on opposite sides of the road require drivers to zigzag or slalom through the chicane. On a shared roadway with two-way traffic where the chicanes restrict concurrent traffic movement in both directions, as indicated in

Figure 5.3, shared use lane markings should not be used. Cyclists are expected to negotiate the right-of-way with other users on the roadway and take the entire lane when navigating around the chicanes.

Alternatively, the chicanes may reduce the width of the travel lanes but not restrict two-way traffic movement, as indicated in **Figure 5.4**. In this case, sharrow markings should be used to provide guidance to cyclists and motorists on the expected positioning of cyclists within the lane. The sharrow should be placed in the centre of the travel lane in each direction. A Shared Use Lane Single File sign Wc-24 (OTM) and accompanying tab sign Wc-24t (OTM) should also be used in advance of the chicanes. Practitioners should refer to **Sections 4.1.1.2** and **4.1.1.3** for details on the Shared Use Lane Single File sign and sharrow markings, respectively.

Figure 5.3 – One-Lane Chicane Roadway with Two-Way Traffic

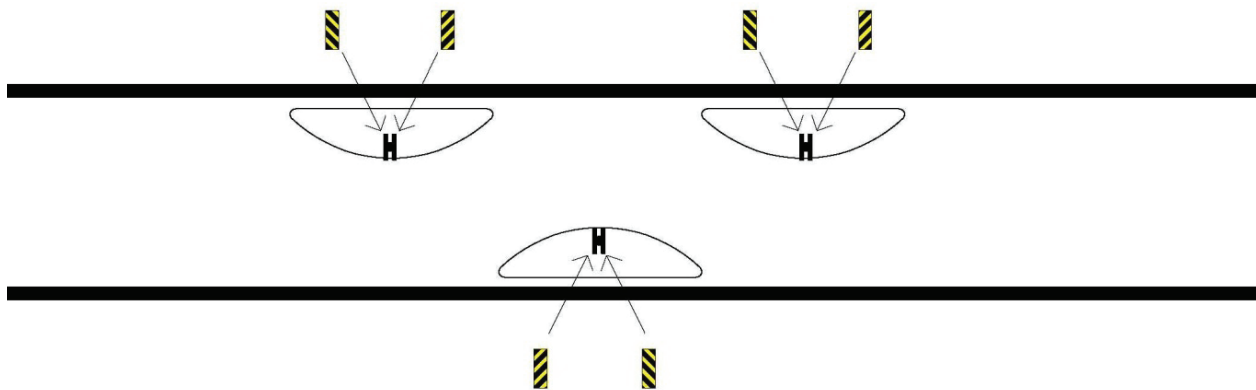

Source: TAC Bikeway Traffic Control Guidelines for Canada, 2012 (Figure 50, p. 99)

Figure 5.4 – Shared Use Markings on Two-Lane Chicaned Roadway

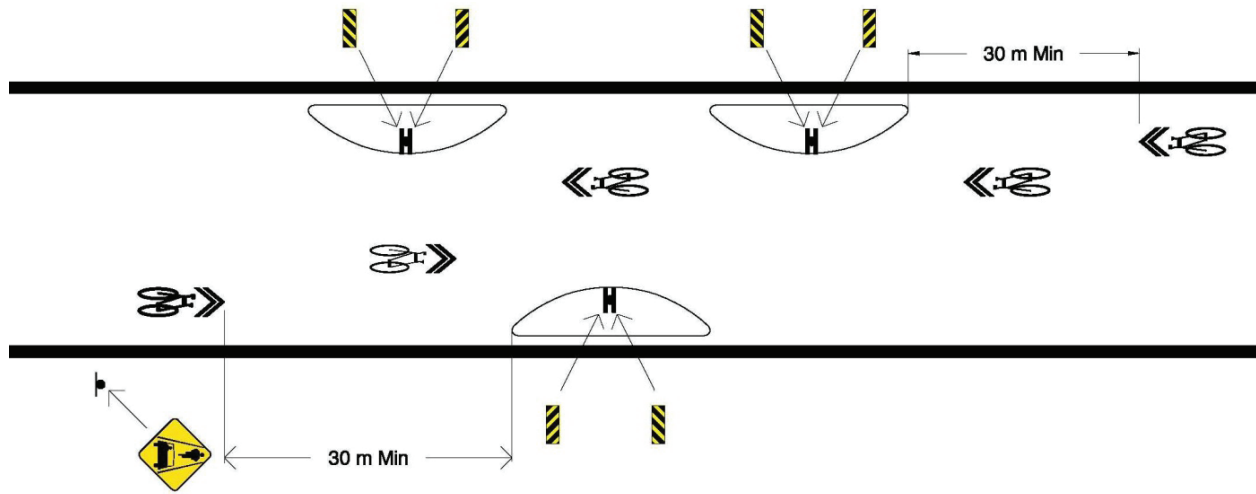

Source: TAC Bikeway Traffic Control Guidelines for Canada, 2012 (Figure 51, p. 100)

Chicanes and Bicycle Lanes

On a roadway with bicycle lanes and chicanes, the bicycle lane should be placed between the curb and the chicane, as illustrated in **Figure 5.5**.

Practitioners should refer to **Section 4.2.1** for further information on the design of Conventional Bicycle Lanes and **Section 4.2.3** for the design of Contraflow Bicycle Lanes.

Figure 5.5 - Bicycle Lane on Chicaned Roadway

(See Table 4.3 for desired and suggested minimum widths for bicycle lanes. As an option, directional arrows may be applied within the bicycle lane)

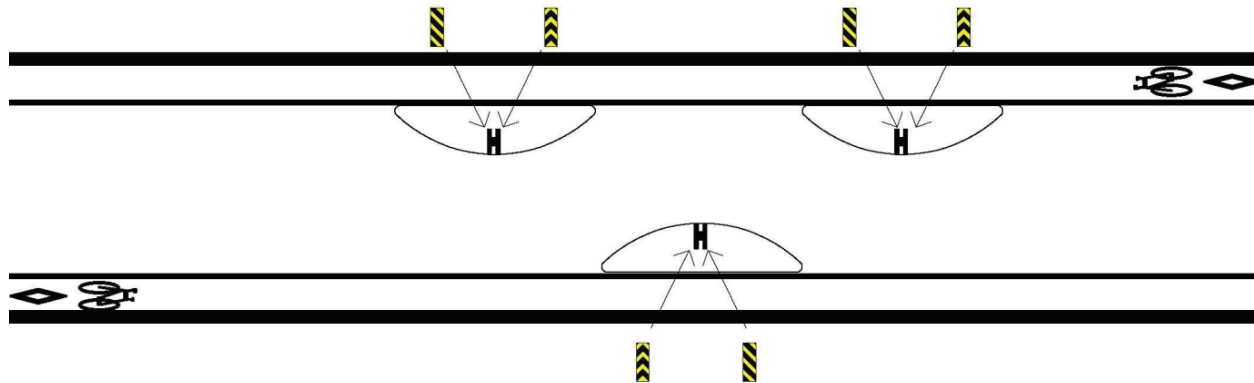

Source: TAC Bikeway Traffic Control Guidelines for Canada, 2012 (Figure 49, p. 99)

Speed Humps and Bicycle Lanes

Where a bicycle lane is located on a roadway with speed humps, carrying the bicycle lane over the hump is optional. However, the bicycle lane should be marked with the triangular pavement marking indicating the start of the speed hump, as illustrated in **Figure 5.6**. The vertical profile of the hump tapers to the same grade as the surrounding pavement in the vicinity of the edge of the gutter (or in its absence, 0.3m from the face of curb) to facilitate drainage.

Figure 5.6 – Bicycle Lane Markings across a Speed Hump

(See Table 4.3 for desired and suggested minimum widths for bicycle lanes. As an option, directional arrows may be applied within the bicycle lane)

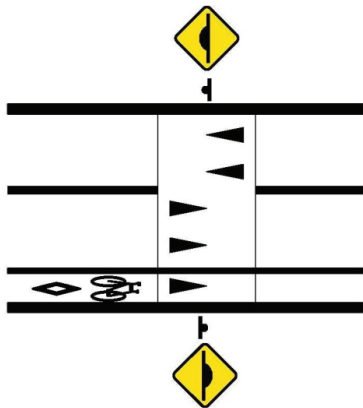

Source: TAC Bikeway Traffic Control Guidelines for Canada, 2012 (Figure 52, p. 100)

5.2 Integrating Bicycle Facilities through Road Retrofits

For new roadways that are identified as potential cycling routes, appropriate bicycle facilities should be planned and integrated at the design stage. However for existing roadways and highways, bicycle facilities may be accommodated and integrated into the roadway through the reconstruction or the reallocation of roadway space. An Environmental Assessment (EA) is often not required for the simple implementation of bike facilities as a standalone project. If incorporated into another project, the value of that will determine the need for the EA.

5.2.1 Retrofitting by Widening the Roadway (Reconstruction)

If the opportunity is available, roadway widening allows for the provision of bicycle facilities with greater separation between motorists and cyclists. Significant budgetary efficiencies may be available when road widening projects for the implementation of bicycle facilities are completed in conjunction with repaving or reconstruction projects that are also planned for the roadway cross-section of interest.

5.2.2 Retrofitting Without Roadway Widening (Reallocation of Road Space)

Retrofitting existing roadways without roadway widening involves the reallocation of space for the implementation of bicycle facilities. This may include:

- Narrowing of vehicular travel lanes where practical and safe;
- Reducing the number of through vehicular travel lanes; or
- Reconfiguring on-street parking or removing it on roadways with low demand.

Bicycle facility widths should adhere to the dimensions given in **Section 4**. Vehicular lane widths should be consistent with municipal or regional guidance; where this is not *available*, practitioners should refer to the *TAC Geometric Design Guide for Canadian Roads*. If there is insufficient space for bicycle lanes, the designer should consider implementing shared use lane pavement markings and signage. Where the addition of bicycle lanes is planned through roadway reallocation but there is a short segment where there is insufficient width, shared lane markings should be used to provide continuity through the constrained section. Signage must be used to indicate where the bicycle lane ends and where it begins again.

A typical reallocation of road space would involve reducing the width of a wide curb lane or other

lanes to provide enough width for a bicycle lane. Another option would be to convert a travel lane into a separated bicycle lane with a buffer.

If roadspace reallocation is not feasible, practitioners may provide shared lane markings (sharrows) or pave the gravel shoulders on a rural roadway to provide additional space for cyclists.

Figure 5.7 shows a site-specific example of how bicycle lanes may be accommodated without the loss of any roadway capacity by taking excess width from vehicular lanes and the median. **Figure 5.8** illustrates another case where the number and width of travel lanes remains unchanged, yet sufficient width has been found for a bicycle lane in each direction by eliminating parking on one side of the street and reducing its width on the other.

Figure 5.7 – An Example of Narrowing Vehicular Lane Widths for the Implementation of Bicycle Facilities

(Dimensions will vary within the design domain)

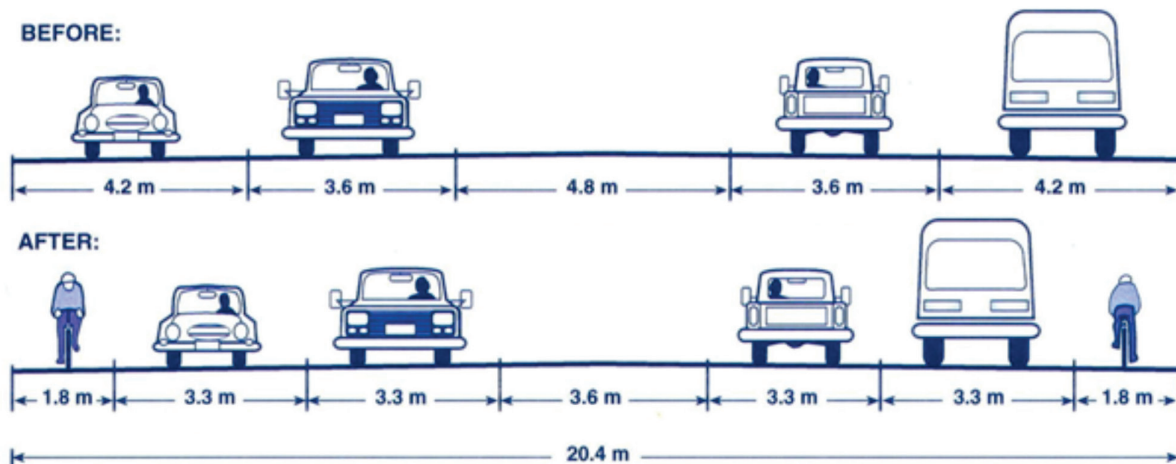

Source: "Complete the Streets – Laying the Foundation" Presentation by John LaPlante, PE., PTOE, TCAT Conference, April 2012

Figure 5.8 – An Example of Removing and Narrowing Parking Lanes for the Implementation of Bicycle Facilities

(Dimensions will vary within the design domain)

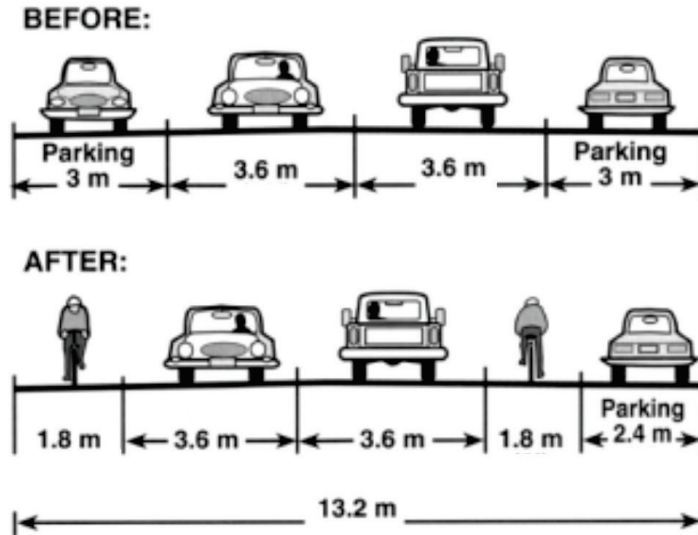

Source: Oregon Bicycle and Pedestrian Plan, Oregon DOT

5.2.3 Road Diet

Another possible reallocation scenario includes a ‘road diet’, where spare roadway capacity associated with excess lanes is redistributed to other modes such as transit or cyclists. The transfer of facilities from automobile to sustainable uses aims to encourage a similar modal shift of road users.

A common example of this is the conversion of a four-lane cross section with no existing median to two travel lanes with a centre left turn lane and two bicycle lanes or raised cycle tracks. This may also include pedestrian refuge islands in the median at key midblock locations.

5.2.4 In-Boulevard Facilities

Another road diet example may be a curb realignment, taking space that was between

the curb and using it to widen the boulevard. This may provide enough width for a multi-use trail, benefitting both cyclists and pedestrians. In some cases, there may be sufficient boulevard width for this without moving the curbs. Even where utility poles, light standards, other municipal infrastructure and trees are present, it is often possible to plot a path around the obstacles with minimal relocations. Where spare boulevard width is available on either side of the road, practitioners should undertake a feasibility assessment to compare the two options. Factors will include utility and municipal relocations, retaining wall requirements, street trees and bus infrastructure.

Practitioners should refer to the *AASHTO Guide for the Planning, Design and Operation of Bicycle Facilities* for more information about retrofitting roadways.

5.3 Integrating Bicycle Facilities at Roundabouts

A roundabout is an intersection treatment that is being increasingly used in place of traffic signals or stop signs. Vehicles are expected to enter the roundabout in order to navigate to their intended destination leg.

5.3.1 Single Lane Roundabout

At single-lane roundabouts, cyclists are expected to share the roadway with motorists. A bicycle lane

should transition to a shared roadway in advance of the roundabout. A Shared Use Lane Single File sign Wc-19 (OTM) with supplementary tab Wc-19t (OTM) and sharrows should be provided to remind users of the expected positioning of the cyclist within the roundabout. **Figure 5.9** illustrates a typical bicycle facility at a single lane roundabout. Practitioners should refer to **Sections 4.1.1.2** and **4.1.1.3** for details on the Shared Use Lane Single File sign and sharrows, respectively.

As an option where cyclists are likely to take the first exit of the roundabout, a bypass may be provided

Figure 5.9 – Bicycle Lane at a Single Lane Roundabout, No Bicycle Bypass

(Signs not directly related to the bicycle facilities have been omitted for clarity. See Table 4.3 for desired and suggested minimum widths for bicycle lanes. As an option, directional arrows may be applied within the bicycle lane)

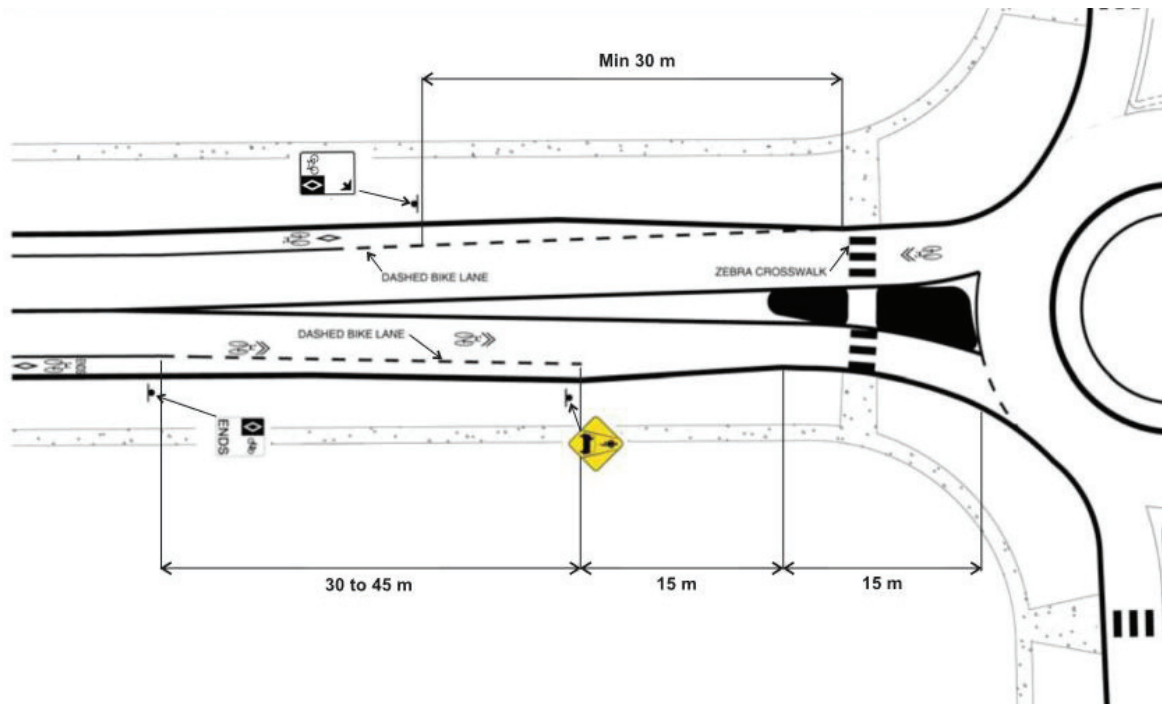

Source: Based on TAC Bikeway Traffic Control Guidelines for Canada, 2012 (Figure 34, p. 88)

in the form of an in-boulevard shared use path, similar to the treatment described for multi-lane roundabouts in **Section 5.3.2**. Cyclist access to and from the bypass facility should be provided by tapered ramps as shown in **Figure 5.10**.

5.3.2 Multi-Lane Roundabouts

Where roundabouts have more than one circulatory lane, there is a greater risk of motor vehicles colliding with cyclists than for single-lane roundabouts. Consequently, cyclists should be given a choice between sharing the roadway with motorists and transitioning to an in-boulevard bypass facility.

The in-boulevard bypass will be a shared use pathway. This gives users the greatest flexibility to avoid conflicts, although where their paths cross, cyclists should yield to pedestrians. The bypass should be surfaced with asphalt, have a desired width of 4 metres (which may be reduced to 3 metres under constrained conditions) and have a yellow directional dividing line.

The bicycle lane should transition to a shared roadway in advance of the roundabout. The bicycle lane lines should be dashed approximately 30 to 45 metres in advance of the end of the bicycle lane to indicate that the cyclist may merge into the adjacent lane.

Bicycle ramps should be provided at the end of the bicycle lane to allow access to the boulevard of the roadway. Designers may decide to taper these so that a cyclist transitioning from the roadway to the shared pathway area is forced to slow down by being deflected laterally as well as vertically. A detectable warning surface should also be provided so that visual impaired pedestrians do not misinterpret the ramp as a transition to a crosswalk. A sample ramp configuration is shown in **Figure 5.10**. A bicycle stencil may be applied on the asphalt landing area

just beyond the bicycle ramp up from the roadway to the multi-use pathway to advise pedestrians that bikes may be merging into the shared use pathway.

For sidewalks adjacent to the asphalt shared use pathway, designers should use concrete slabs or some other contrasting material. This will highlight the transition between the two facilities, and discourage cyclists from riding on the sidewalk. Practitioners have the option of installing a 'Dismount and Walk' sign (Rb-70, **Figure 4.93**) at the transition from shared pathway to sidewalk. However, the cyclist should have a clear view of the Reserved Bicycle Lane sign so they realize they can take the ramp down to the adjacent on-road bicycle lane, and hence continue without dismounting. Crossrides (typically unsignalized) should be provided where the pathway intersects with the roadway. Wayfinding signs should be provided where a particular site warrants it.

Practitioners should refer to **Section 4.2.1** for the design of a bicycle lane and **Section 4.4.1** for the design of an in-boulevard shared use pathway and a crossride. **Figure 5.11** illustrates a typical plan view of a bicycle facility at a multi-lane roundabout.

Figure 5.10 – Tapered Ramp Example

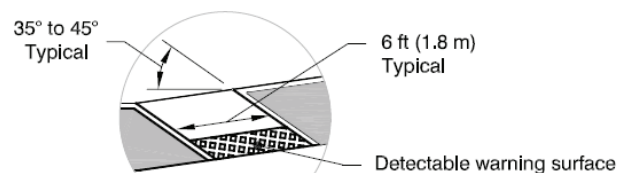

Source: FHWA (Figure 19)

Figure 5.11 – Bicycle Lane at a Multi-lane Roundabout with Bicycle Bypass

(Signs not directly related to the bicycle facilities have been omitted for clarity. See Table 4.3 for desired and suggested minimum widths for bicycle lanes. As an option, directional arrows may be applied within the bicycle lane)

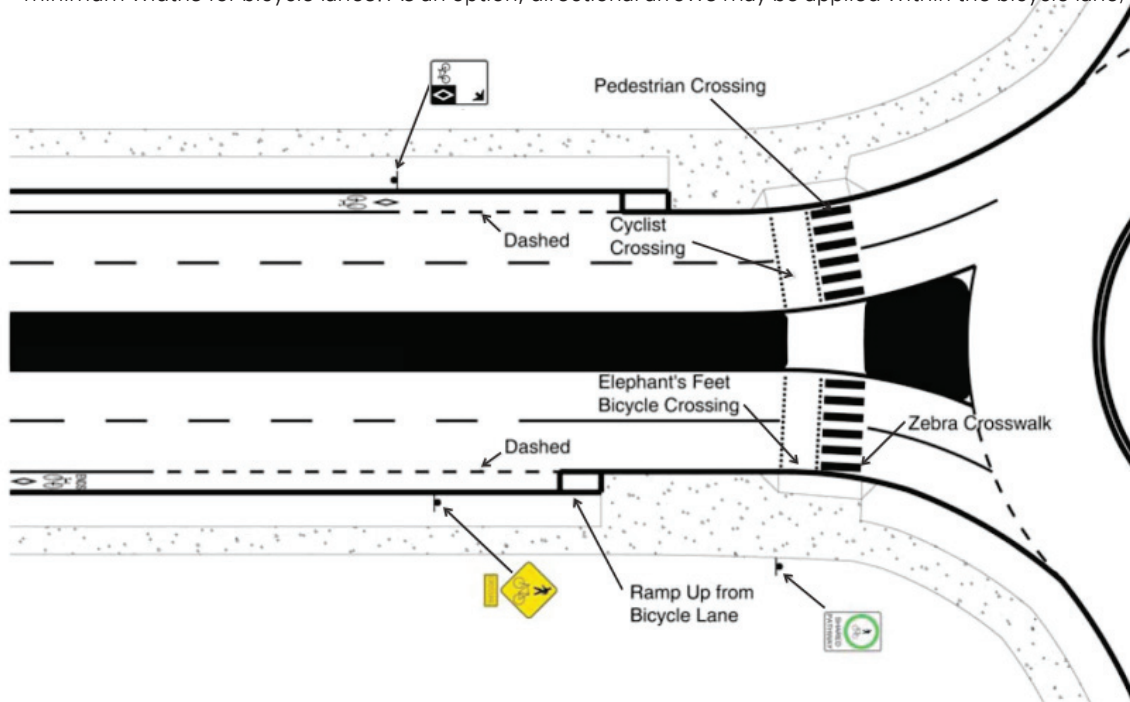

Source: TAC Bikeway Traffic Control Guidelines for Canada, 2012 (Figure 35, p. 89)

5.4 Conflict Zones

A conflict zone is an area where different types of road user cross travel paths and, therefore, the risk of collisions is higher.

5.4.1 Motorist – Cyclist Conflicts

These conflicts generally occur where a cyclist is making a through movement and a motorist is turning. They can occur within the roadway, particularly through intersections and ramp entry and exit points, as discussed in **Section 5.4.1.1**.

They can also occur when facilities that are outside of the travelled way cross a leg of an intersection

where motorists may be turning. Further guidance is given in **Section 5.4.1.2**.

5.4.1.1 On-Road Conflicts

This configuration of conflict zones for motorists and cyclists includes intersections, interchange ramps and private entrances. Pavement markings may be applied to provide guidance to cyclists and motorists in conflict zones.

Several examples of intersection treatments and associated signage are given in **Section 4**. In addition to these, practitioners should give particular

attention to interchanges and ramp crossings since the speed differential between cyclists and motor vehicle traffic will be significant at these locations.

Elephant’s feet markings are reserved for crossrides at intersections. They should not be marked through the intersections themselves.

The measures available for marking a bicycle facility through a conflict zone, in increasing order of visibility are:

In all cases, the measure used should extend through the conflict zone, whether at an intersection or elsewhere.

- no treatment;
- bike stencils or chevrons at 1.5 m to 10 m spacing (with optional directional arrows to clarify cyclist trajectories);
- sharrows at 1.5 m to 15 m spacing as shown in **Figure 5.12**;
- dashed guide lines (with optional bike stencils or chevrons but not sharrows) as shown in **Figures 5.13 and 5.14**;
- green surface treatment; or
- dashed guide lines (with optional bike stencils or chevrons but not sharrows) and green surface treatment.

Additionally, practitioners may consider the use of green surface treatment or separation through conflict zones to increase the visibility of the bicycle facility. Refer to **Section 5.5.1** for an example design application.

Practitioners should also consider situations where cyclists are travelling or waiting between active or stationary traffic. Please refer to **Table 4.3** for guidance where conventional bike lanes are splitting two travel lanes at an intersection, operating in a contraflow direction or alongside on-street parking.

Figure 5.12 – Sharrow Markings in a Conflict Zone

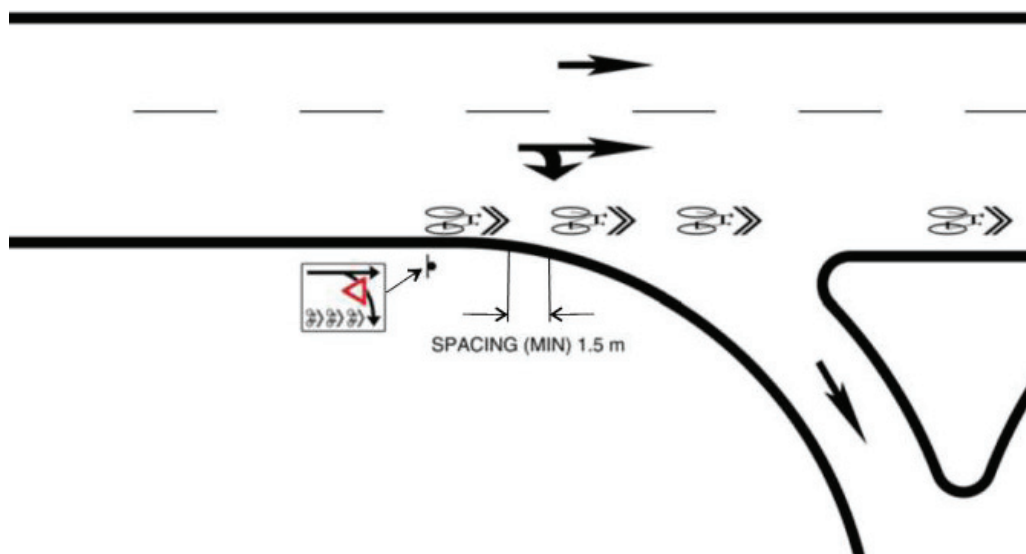

Source: TAC Bikeway Traffic Control Guidelines for Canada, 2012 (Figure 54, p. 102)

Figure 5.13 – White Dashed Markings in a Conflict Zone

(See Table 4.3 for desired and suggested minimum widths for bicycle lanes. As an option, directional arrows may be applied within the bicycle lane)

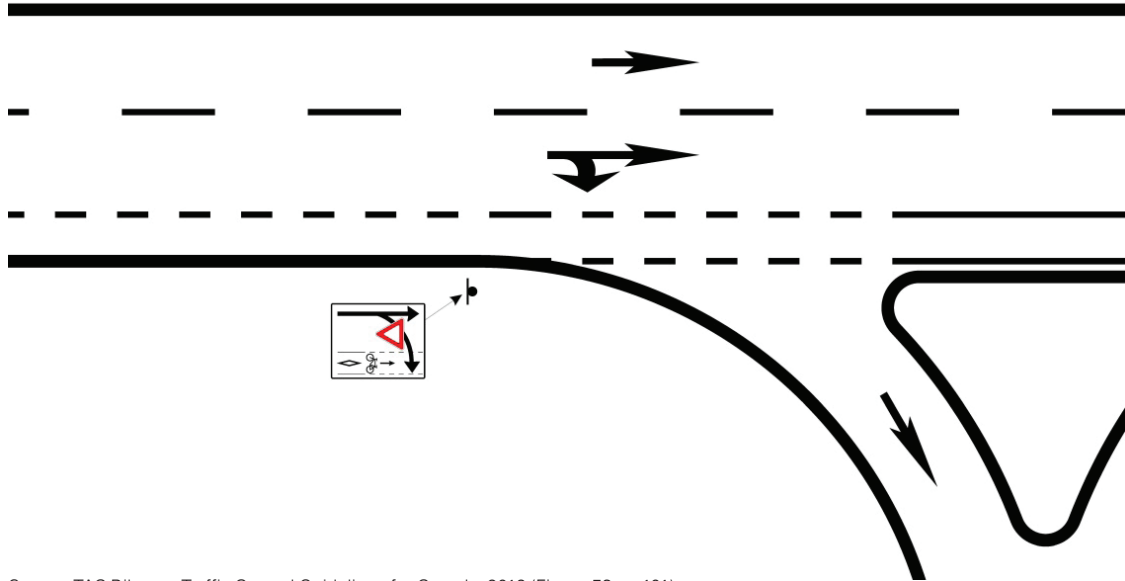

Source: TAC Bikeway Traffic Control Guidelines for Canada, 2012 (Figure 53, p. 101)

Figure 5.14 – White Dashed Bicycle Markings and Bicycle Stencils in a Conflict Zone

(See Table 4.3 for desired and suggested minimum widths for bicycle lanes. As an option, directional arrows may be applied within the bicycle lane)

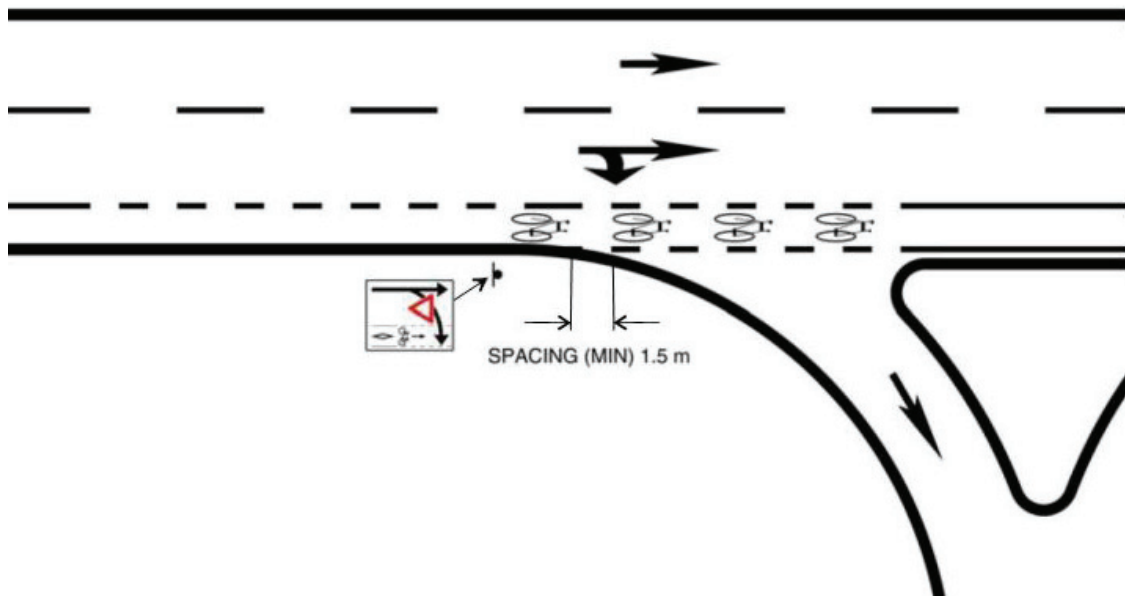

Source: TAC Bikeway Traffic Control Guidelines for Canada, 2012 (Figure 55, p. 102)

5.4.1.2 Crossing Point Conflicts

Raised cycle tracks, in-boulevard facilities and separated bike lanes are physically apart from the travelled portion of the roadway. This may present conflicts for both one-way and two-way facilities where they cross the leg of an intersection. However, this section considers the bidirectional case since it covers the largest number of conflicts.

Cyclists may be less visible to drivers because street furniture, utility infrastructure and other objects in the boulevard may obscure their view of the cyclist. This is particularly true of in-boulevard facilities.

Where a two-way facility crosses an intersection, drivers may not expect to encounter a cyclist travelling in the opposite direction to motor vehicles in the adjacent roadway. The issue is compounded by the fact that two-way raised cycle tracks are physically separate from the travelled portion of the roadway. Hence, cyclists using them are sometimes less visible to the driver.

Conflict points exist at roadway and driveway crossings, creating operational and safety problems for both cyclists and motorists using two-way facilities. The following issues may arise:

- Motorists entering or crossing the roadway (Driver A in **Figure 5.15**) from a cross-street or driveway are looking for traffic coming from the left and may not notice cyclists approaching from the right.
- Motorists turning left from the main roadway parallel to the raised cycle track onto the cross-street or driveway (Driver B in **Figure 5.16**) are looking for traffic ahead and may fail to notice cyclists travelling in the same

direction as them.

- Motorists turning right from the main roadway parallel to the raised cycle track onto the cross-street or driveway (Driver C in **Figure 5.17**) may not expect a cyclist to be crossing since the two-way raised cycle track is physically separate from the travelled portion of the roadway and is sometimes less visible to the driver.
- Motorists stopped on a cross-street or driveway may block cyclists travelling along an in-boulevard facility, as shown in **Figure 5.18**. Therefore, in-boulevard facilities may not be suitable on routes where there are a large number of side streets or driveway entrance and exit points.
- At the end of a two-way raised cycle track, cyclists travelling in the opposite direction to adjacent motor vehicle traffic may continue along the wrong side of the roadway, sometimes to access an in-boulevard facility entrance point.

Practitioners should consider the following mitigation measures:

- Where no signal control is present for raised cycle track and in-boulevard crossings, signalized crossrides may be installed. Dedicated bicycle signals and separate phasing are required to accommodate two-way cyclist travel on one side of the roadway, whereas conventional traffic signals are sufficient for one-way operation. Crossrides should not be used for two-way separated bicycle lanes. Instead, a dedicated signal phase should be introduced within the intersection operation.

- Improve sightlines by removing or relocating roadside furniture and vegetation. Provide adequate space for cyclists either on or off the roadway. Design intersection crossings to minimize and clearly mark conflicts, and restrict parking in close proximity to intersections.
- Where the two-way facility crosses a driveway with high vehicle volumes, the Turning Vehicles Yield to Bicycles sign RB-37 (TAC) may be installed at the practitioner's discretion. The bicycle facility shown on the sign should match the facility provided on the ground;
- Practitioners may wish to only apply two-way raised cycle tracks alongside one-way streets. Vehicles in the roadway parallel to the raised cycle track will only approach from one direction, thus reducing the number of conflicts with cyclists.

Figures 5.15 – 5.17 show how different conflict situations may arise depending on the direction of the cyclist relative to traffic in the adjacent general traffic lane and the road from which the driver is making the turn. Where the practitioner believes that any of these conflicts are particularly problematic, the corresponding turning movement may be restricted.

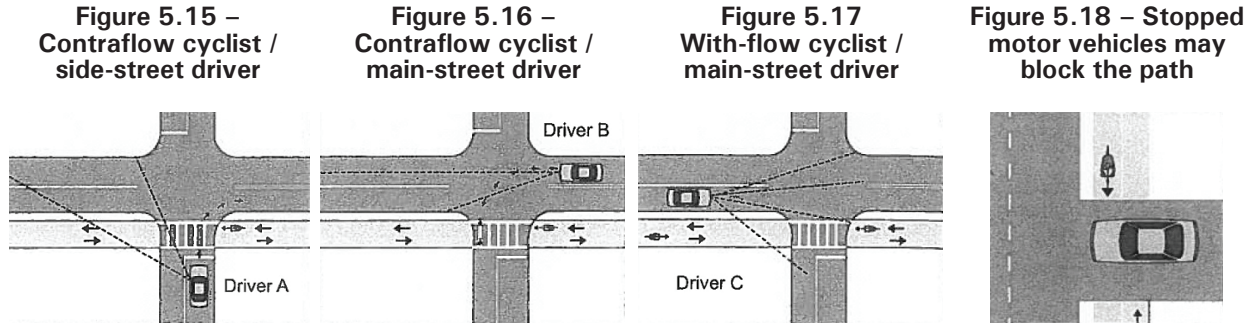

(The ladder markings indicate the crossing area and are not recommended as pavement markings)

Source: AASHTO, 2012

5.4.2 Transit Stops

Where on-road bicycle facilities coincide with transit routes, practitioners should carefully consider the on-road interaction of cyclists with buses, streetcars and other transit vehicles. This is particularly critical at transit stops where bus bays are present. In this situation, buses must cross the curbside bicycle lane to access the bus bay. This area is indicated by dashed lines as shown in **Figure 5.19**. Unlike permanent on-street parking, bus bays do not require buffers since no passengers will be alighting on the side of the bicycle lane.

Where no bus bay is provided, buses must manoeuvre up to the curb to minimize the gap across which passengers must board or alight, thus encroaching on any curbside bicycle lane. Transit vehicles will decelerate and move laterally on the approach to a stop, causing cyclists to also slow or change position. In such cases, practitioners may consider incorporating the bicycle facility

into the transit platform as shown in **Figures 5.20 and 5.21**. Designers should take care to minimize conflicts with passengers boarding, alighting or waiting for transit. The bicycle facility should feature a ramp up to the platform to slow cyclists as they approach the conflict area. The paving materials for the sidewalk should contrast with the asphalt raised cycle track. It is also recommended that the area where passengers board and alight be surrounded by bright yellow tactile paving. This clearly defines the conflict zone for all users, including those who are visually impaired.

For in-boulevard facilities, practitioners should design the bicycle facility to pass behind transit stops. Where this is not feasible due to right-of-way constraints, the shelter should be located as far from the bicycle facility as possible to attract waiting transit users away from the conflict area.

Figure 5.19 – Bicycle Lane Passing a Transit Stop

(See Table 4.3 for desired and suggested minimum widths for bicycle lanes. As an option, directional arrows may be applied within the bicycle lane)

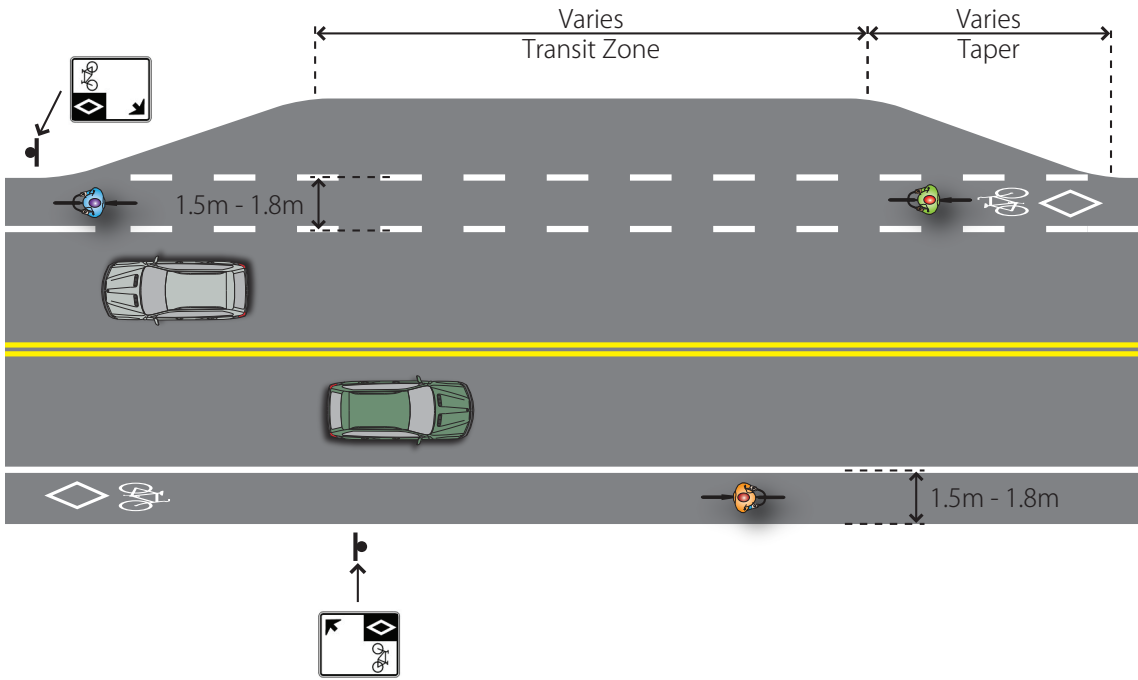

Source: MMM/ALTA, 2013

**Figure 5.20 – Cycle Facility at Transit Stop
(Roncesvalles Avenue, Toronto)**



Credit: Google, 2013

**Figure 5.21 – Cycle Facility at Transit Stop
(Sherbourne Street, Toronto)**



Credit: City of Toronto

5.5 Integrating Bicycle Facilities at Interchanges and Ramp Crossings

5.5.1 Bicycle Lane Across Lower Speed Diverging Ramp Facility

At a lower speed (less than or equal to 70 km/h) diverging ramp with a through curb lane, the bicycle lane should be carried across the ramp entrance

using dashed white guide lines beginning 30 metres in advance of the ramp. **Figure 5.22** provides a plan of this application. Practitioners may consider applying alternative conflict zone markings within the bicycle lane at the ramp entrance. Please refer to **Section 5.4.1.1** for guidance on the options available.

Figure 5.22 – Bicycle Lane across Lower Speed (≤ 70 km/h) Diverging Ramp Facility

(See Table 4.3 for desired and suggested minimum widths for bicycle lanes. As an option, directional arrows may be applied within the bicycle lane)

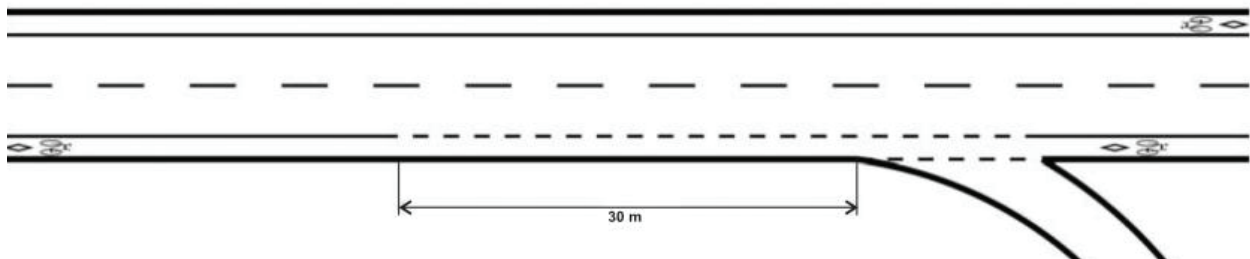

Source: TAC Bikeway Traffic Control Guidelines for Canada, 2012 (Figure 27, p. 83)

At a low-speed ramp where road right-of-way widths do not allow for the implementation of a jug handle, a context specific design application may be considered. **Figure 5.23** illustrates an example plan view where the bicycle lane continues adjacent to the curb lane across the ramp. Within the conflict zone across the entrance to the ramp, the bicycle lane may be marked with green surface

treatment or pavement markings and with white bicycle symbols. Please refer to **Section 5.4.1.1** for guidance on the available treatments and Table 4 of OTM Book 6 for guidance on the placement of signs directed at motor vehicles. These pavement markings reinforce to both cyclists and motorists that they may cross paths within the conflict zone at the ramp entrance.

Figure 5.23 – Context Specific Example of Cyclist Crossing at Low-Speed On-Ramp with Green Surface Treatment and Pavement Markings

(See Table 4.3 for desired and suggested minimum widths for bicycle lanes. As an option, directional arrows may be applied within the bicycle lane)

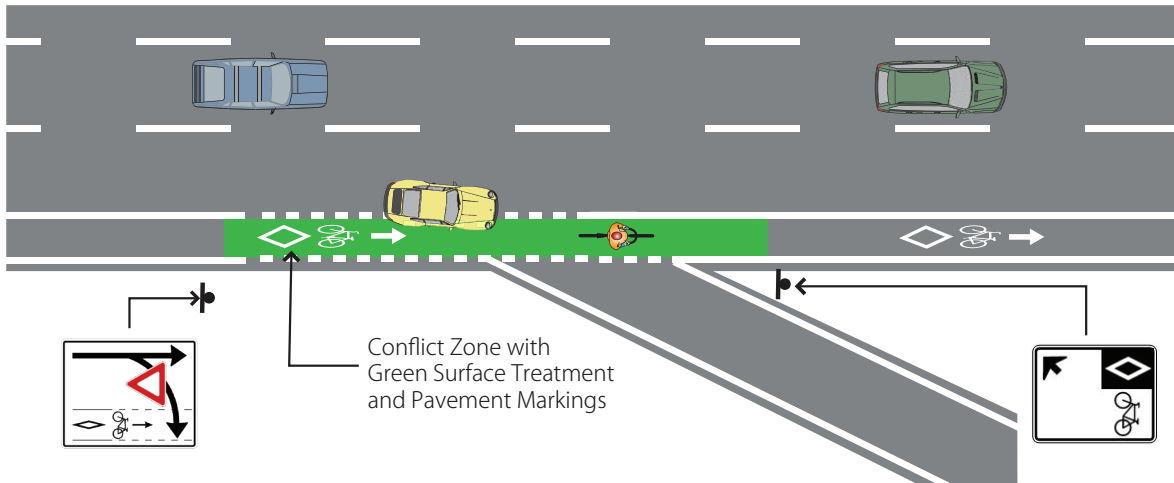

Source: MMM/ALTA, 2013

5.5.2 Bicycle Lane Across Lower Speed Diverging Ramp Facility with Parallel Lane

At a lower speed (less than or equal to 70 km/h) diverging ramp with a parallel exit curb lane, the bicycle lane should be located between the through lane and the exit lane. The treatment should begin a minimum of 15 metres in advance of the parallel

lane, at which point a Reserved Bicycle Lane sign Rb-84A (OTM) or RB-91 (TAC) should be installed. **Figure 5.24** provides a plan showing one possible treatment, namely the dashed guide lines. Please refer to **Section 5.4.1.1** for details of the options available and Table 4 of OTM Book 6 for guidance on the placement of signs directed at motor vehicles.

Figure 5.24 – Bicycle Lane across Lower Speed (≤ 70 km/h) Diverging Ramp Facility with Parallel Lane

(See Table 4.3 for desired and suggested minimum widths for bicycle lanes. As an option, directional arrows may be applied within the bicycle lane)

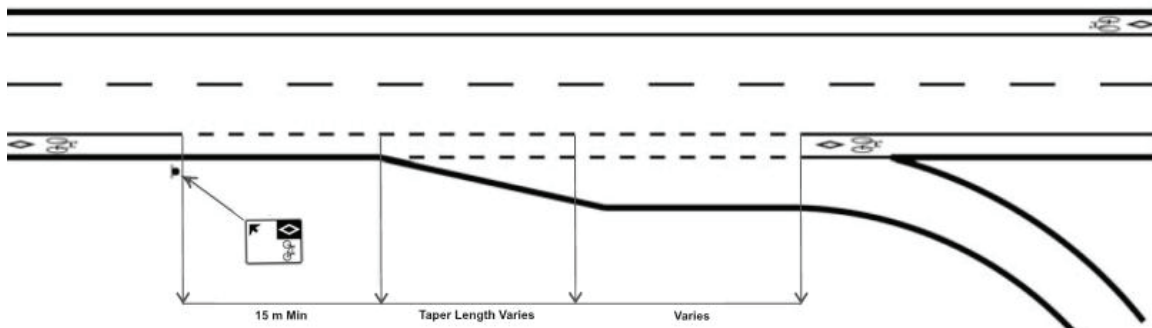

Source: TAC Bikeway Traffic Control Guidelines for Canada, 2012 (Figure 28, p. 84)

5.5.3 Bicycle Lane Across Lower Speed Merging Ramp Facility

At a lower speed (less than or equal to 70km/h) merging ramp without an acceleration lane, the bicycle lane may be carried straight across using conflict zone markings. A Reserved Bicycle Lane Ahead sign WB-10 (TAC) and a yield sign Ra-2 (OTM) should be placed on the ramp upstream of the conflict point to warn motorists of the approaching bicycle facility. A Reserved Bicycle

Lane Sign Rb-84A (OTM) or RB-91 (TAC) should be placed on the far side of the merging ramp. **Figure 5.25** provides a plan of this application with dashed white guide lines. Practitioners may consider applying alternative conflict zone markings within the bicycle lane at the ramp entrance. Please refer to **Section 5.4.1.1** for details of the options available and Table 4 of OTM Book 6 for guidance on the placement of signs directed at motor vehicles.

Figure 5.25 – Bicycle Lane across Lower Speed (≤ 70 km/h) Merging Ramp Facility

(See Table 4.3 for desired and suggested minimum widths for bicycle lanes. As an option, directional arrows may be applied within the bicycle lane)

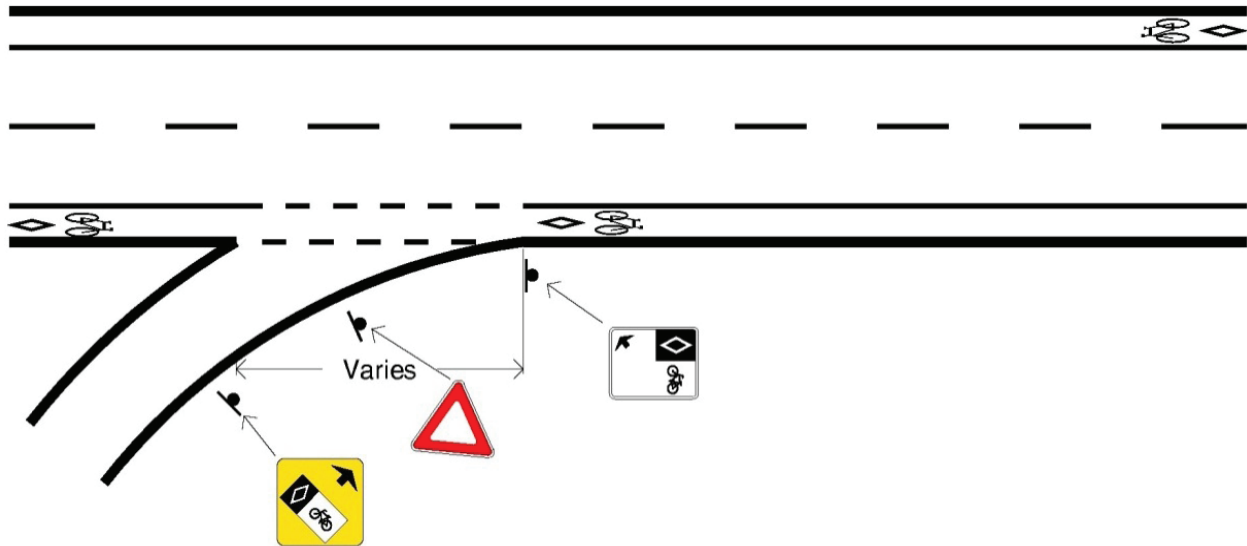

Source: TAC Bikeway Traffic Control Guidelines for Canada, 2012 (Figure 29, p. 84)

5.5.4 Bicycle Lane Across Lower Speed Merging Ramp Facility with Acceleration Lane

At a lower speed merging ramp with a parallel acceleration lane, the bicycle lane should be located between the through lane and the acceleration lane, and should be marked with two dashed white lines. A Bicycle Crossing Ahead sign WC-7 (TAC) and a Reserved Bicycle Lane Ahead sign WB-10 (TAC) should be placed upstream of the acceleration lane

to warn motorists of the upcoming cycling facility. A Reserved Bicycle Lane Sign Rb-84A (OTM) or RB-91 (TAC) may be placed on the far side of the merging ramp. **Figure 5.26** provides a plan of the application with dashed white guide lines. Practitioners may consider applying alternative conflict zone markings within the bicycle lane at the ramp entrance. Please refer to **Section 5.4.1.1** for details of the options available and Table 4 of OTM Book 6 for guidance on the placement of signs directed at motor vehicles.

Figure 5.26 – Bicycle Lane across Lower Speed (≤ 70 km/h) Merging Ramp Facility with Acceleration Lane

(See Table 4.3 for desired and suggested minimum widths for bicycle lanes. As an option, directional arrows may be applied within the bicycle lane)

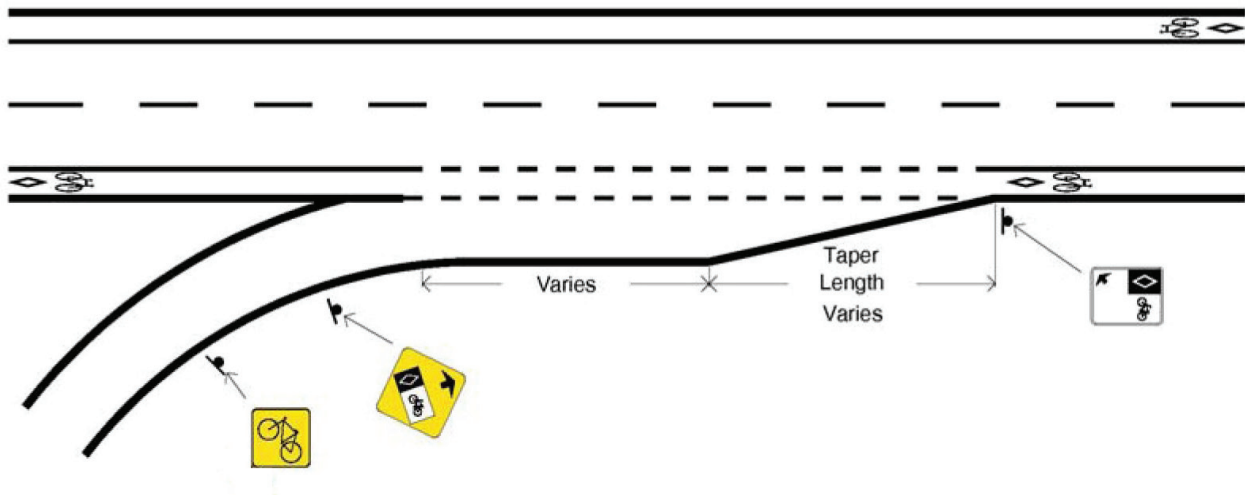

Source: Based on TAC Bikeway Traffic Control Guidelines for Canada, 2012 (Figure 30, p. 85)

5.5.5 Bicycle Crossing of a High-Speed Diverging Ramp

Due to the speed differential between motor vehicles on a high-speed (greater than 70km/h) diverging ramp and cyclists crossing the ramp, practitioners should pay special attention to such locations. Bicycle crossings should be located downstream from the diverge point of the ramp to create a shorter crossing distance and improve sight lines for both cyclists and motorists. A widened shoulder may be provided near the crossing to allow cyclists to position themselves and wait for a safe gap in traffic to cross. The Bicycle Crossing Ahead sign WC-7 (TAC) and supplementary tab WC-7S (TAC) should be placed in advance of the ramp to indicate to motorists that cyclists may be

crossing the ramp facility. The green Bicycle Route Marker M511 (OTM) should be installed to indicate to cyclists and motorists the route deviations near the ramp facility. A Bicycle Yield at High Speed Ramp sign RB-40 (TAC) should also be installed near the intended crossing. **Figure 5.27** illustrates a typical plan view. Please refer to Table 4 of OTM Book 6 for guidance on the placement of signs directed at motor vehicles.

Practitioners should evaluate the characteristics of the traffic flow on the roadway, in particular the amount of time cyclists will be required to wait for a gap before crossing the ramp as indicated by the markings and signage. Where ramps are frequent and wait times will be significant, alternate routes for cyclists should be considered.

Figure 5.27 – Bicycle Crossing at a High-Speed Diverging Ramp

(See Table 4.3 for desired and suggested minimum widths for bicycle lanes. As an option, directional arrows may be applied within the bicycle lane. The cycling facility can be signed using either the green bike route marker or reserved bicycle lane signage depending on the facility type across the interchange.)

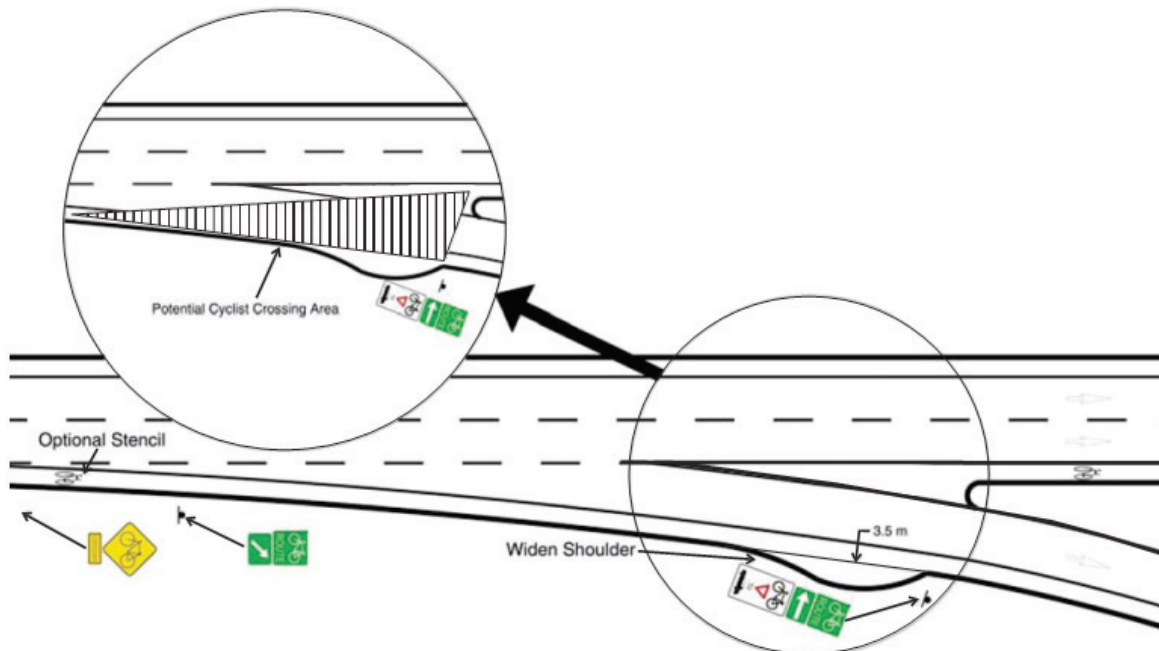

Source: Based on TAC Bikeway Traffic Control Guidelines for Canada, 2012 (Figure 31, p. 86)

5.5.6 Bicycle Lane Jug Handle at Diverging Ramp Facility

The Jug Handle is an optional treatment for a diverging ramp facility that may be applied where right-of-way is available. It is an extension of the bicycle lane within the boulevard of the ramp. It enables cyclists to cross as close to a right angle as possible at the ramp. The green Bicycle Route Marker M511 (OTM) should be installed to indicate to cyclists and motorists that the route deviates near the ramp facility. The Bicycle Crossing Ahead sign WC-7 (TAC) and supplementary tab WC-7S (TAC) should be placed in advance of the crossing to indicate to motorists that cyclists may be crossing

the ramp facility. A yield sign Ra-2 (OTM) should also be installed at the intended crossing. **Figure 5.28** illustrates a typical plan view. Please refer to Table 4 of OTM Book 6 for guidance on the placement of signs directed at motor vehicles.

Practitioners should evaluate the characteristics of the traffic flow on the roadway, in particular the amount of time cyclists will be required to wait for a gap before crossing the ramp as indicated by the markings and signage. Where ramps are frequent and wait times will be significant, alternate routes for cyclists should be considered.

Figure 5.28 – Bicycle Lane Jug Handle at Diverging Ramp Facility

(See Table 4.3 for desired and suggested minimum widths for bicycle lanes. As an option, directional arrows may be applied within the bicycle lane. The cycling facility can be signed using either the green bike route marker or reserved bicycle lane signage depending on the facility type across the interchange.)

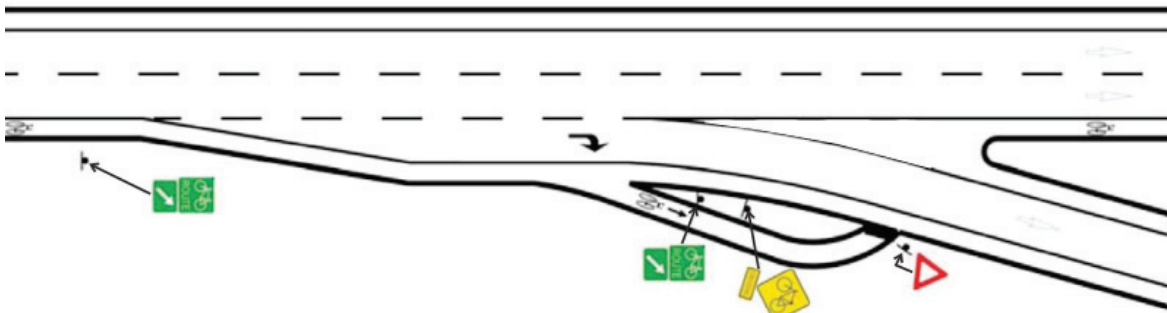

Source: Based on TAC Bikeway Traffic Control Guidelines for Canada, 2012 (Figure 32, p. 86)

5.5.7 Bicycle Crossing at a High-Speed Merging Ramp

Due to the speed differential between motor vehicles on a high-speed (greater than 70km/h) merging ramp and cyclists crossing the ramp, practitioners should pay special attention to such locations. Cyclists should be encouraged to cross near the bullnose where the crossing distance is shorter and there is improved task separation for both cyclists and motorists. The green Bicycle Route Marker M511 (OTM) should be installed at the bullnose to indicate to cyclists and motorists that the route deviates near the ramp facility. A Bicycle Yield at High Speed Ramp Sign (RB-40)

should also be installed. A Bicycle Crossing Ahead sign WC-7 (TAC) and supplementary tab WC-7S (TAC) should be installed on the ramp warning motorists of the bicycle crossing ahead. **Figure 5.29** illustrates a typical plan view. Please refer to Table 4 of OTM Book 6 for guidance on the placement of signs directed at motor vehicles.

Practitioners should evaluate the characteristics of the traffic flow on the roadway, in particular the amount of time cyclists will be required to wait for a gap before crossing the ramp as indicated by the markings and signage. Where ramps are frequent and wait times will be significant, alternate routes for cyclists should be considered.

Figure 5.29 – Bicycle Crossing at a High-Speed Merging Ramp

(See Table 4.3 for desired and suggested minimum widths for bicycle lanes. As an option, directional arrows may be applied within the bicycle lane)

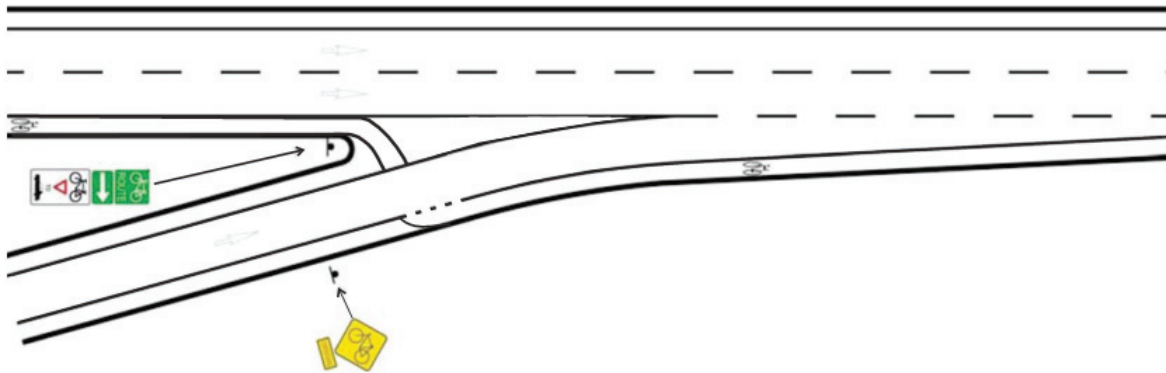

Source: Based on TAC Bikeway Traffic Control Guidelines for Canada, 2012 (Figure 33, p. 87)

5.6 Integrating Bicycle Facilities at Grade Separations

Cyclists frequently need to use a grade separation to cross major barriers such as highways and waterways to reach key destinations. A bikeway must sometimes continue over a bridge or through a tunnel to overcome these major obstacles. Existing structures may need to be modified to safely integrate cyclists with other roadway users. A bicycle facility may be integrated into a grade separation structure by:

- Narrowing vehicular travel lanes, where practical and safe, to implement a bicycle lane or a signed bicycle route with a paved shoulder; or
- Converting and widening the sidewalk into a shared use active transportation path, where available right-of-way exists.

Practitioners should exercise good engineering judgement to design a bicycle facility appropriate for the local conditions at a grade separation. The design considerations include traffic volume, posted speed, roadway geometry and available right-of-way width. Bicycle facility lane widths should adhere to the design domain outlined within **Sections 4.1 to 4.4**, and vehicular lane widths should be in accordance with the 1999 TAC Geometric Design Guide for Canadian Roads. If it is not possible to provide a facility that meets at least the suggested minimum widths, alternate routes that avoid the constrained location should be considered. Refer to **Section 5.2.2** for more information on the reallocation of roadway space.

The design of new structures or the modification of existing bridges must comply with the standards of the *Canadian Highway Bridge Design Code (2002)*.

When reconstructing bridge decks, practitioners should consider the feasibility of introducing bicycle lanes. **Section D.7.2.3** of the MTO *Geometric Design Standards for Ontario Highways* provides guidance with regard to sidewalks, curbs and bicycle routes on bridges.

Table 5.1 and **Figure 5.30** set out the minimum side clearances at bridges prescribed by MTO. This is the distance between the edge of the travelled way and the adjacent curb or barrier. The side clearance on the bridge deck should match the shoulders on the approaches, but should not be less than the minimum side clearance specified in **Table 5.1**. Practitioners should refer to **Section 5.9.2** for guidance on fences, railings and barriers.

Section D.7.2.5 of the MTO *Geometric Design Standards for Ontario Highways* also provides guidance with regard to roadways at underpasses:

- Where practicable, underpassing roadway cross-sections should match that of the approach roadway; and
- Horizontal clearances from the edge of the through travelled way to the face of an abutment or pier should meet or exceed minimum clear zone widths in the Ministry's Roadside Safety Manual.

Practitioners may also consider the design and implementation of a separated bicycle and pedestrian crossing outside the road right-of-way. *OTM Book 15 – Pedestrian Crossing Facilities: Section 4 – Physically Separated Facilities* provides guidance on a need and feasibility assessment process for grade separated pedestrian crossings.

Table 5.1 – Minimum Side Clearances at Bridges

	Design Speed (km/h)	Urban Roads			Rural Roads		
		Left	Right		Left	Right	
			No Sidewalk	Sidewalk		No Sidewalk	Sidewalk
FREEWAY 4-LANE DIVIDED	100 to 120	2.5a	3.0 a		2.5a	3.0 a	
FREEWAY MULTI-LANE DIVIDED	100 to 120	2.5 a	3.0 a		2.5 a	3.0 a	
ARTERIAL DIVIDED	90 to 110	2.0 a	2.5 a	1.5	2.0	3.0 a	
	80	2.0 a	2.5 a	1.5	1.5	2.5 a	
ARTERIAL UNDIVIDED	90 to 110	-	2.0	1.5	-	3.0 a	2.5 a
	80	-	2.0	1.5	-	2.5 a	2.0 b
COLLECTOR UNDIVIDED	90 to 100	-	1.25 c	1.0	-	2.5 a	1.5 c
	70 to 80	-	1.25 c	1.0	-	1.5 d	1.25
	60	-	1.0	1.0	-	1.5 d	1.25
LOCAL UNDIVIDED	60 to 80	-	1.0	0.5	-	1.25	0.5 d

Notes:

1. If a barrier is to be placed between the sidewalk and roadway, then clearance should be the same as when there are no sidewalks.
2. All clearance should meet requirements for sight distance.
3. The width of a median on a bridge should match that of the approach roadway.
4. L = Length of bridge between centreline of abutment bearings.

a - For bridges with L>50 m, consideration can be given to decreasing the clearances to 1.5 m.
 b - For bridges with L>50 m, consideration can be given to decreasing the clearance by up to 0.5 m.
 c - For bridges with L>50 m, consideration can be given to decreasing the clearance by 0.25 m.
 d - For bridges with L>50 m, consideration can be given to increasing the clearance by up to 0.75 m.
 e – The values of the clearances given above are the minimum values. Consideration may be given to providing more than the minimum if justification is provided.

Source: MTO Geometric Design Standards for Ontario Highways – Revision Information Sheet, February 2002, Table D7-1

Figure 5.30 – Side Clearances at Bridges

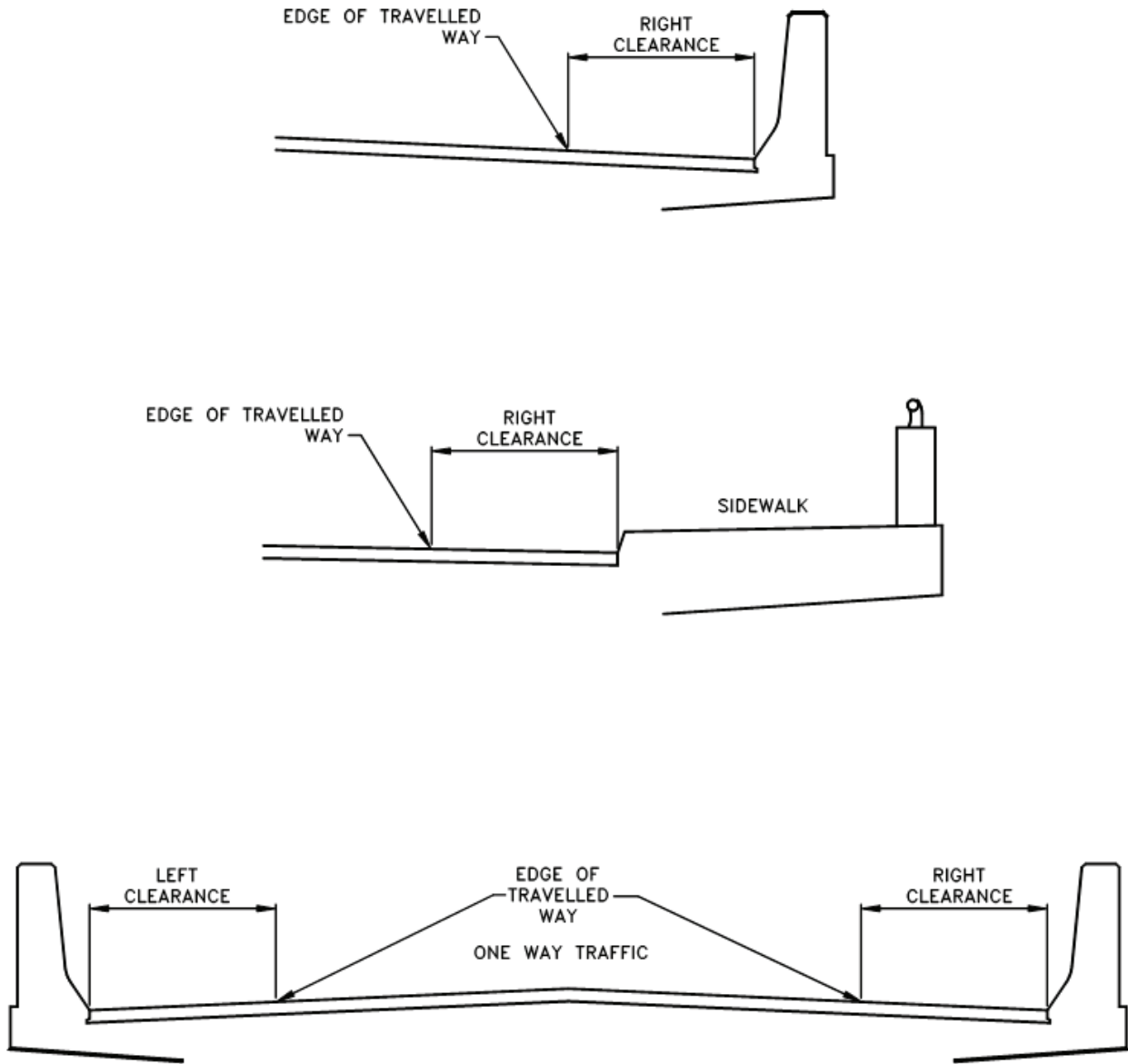

Source: MTO Geometric Design Standards for Ontario Highways – Revision Information Sheet, February 2002, Figure D.7-1

5.7 Integrating Bicycle Facilities at Railway Crossings

Railway tracks crossing roadways pose a hazard to cyclists for the following reasons:

- There may be surface elevation differences between the roadway pavement, grade crossing and rails;
- There may be gaps on either side of the rail which can trap a bicycle wheel; and
- Rails can be slippery when wet.

Railway tracks can be especially difficult to cross for cyclists if the railway is not perpendicular to the bicycle facility. Crossings should be designed as close to a right angle as possible. In situations where the road and the rails cannot intersect at or near a 90 degree angle, the shoulder may be widened in advance of the crossing. This allows cyclists to compensate by reducing their speed and positioning themselves more appropriately.

If space permits, another option is to design a bicycle lane jug handle at the skewed railway crossing which allows for the bicycle facility to be aligned perpendicular to the railway tracks. In both

cases an Automobiles and Motorcycles Prohibited sign RB-89 (TAC) should be used. **Figures 5.31** and **5.32** illustrate a bicycle lane (with no jug handle) at a skewed railway crossing, with and without gate control, respectively.

Where a bicycle lane crosses a skewed railway and the road right-of-way is restricted, practitioners have the option of providing a dashed bicycle lane line for at least 15 metres in advance of the crossing to indicate to both motorists and cyclists that the cyclist may merge into the adjacent lane in order to position themselves to cross the railway.

Figure 5.33 and **5.34** illustrate bicycle lanes with a jug handle at a skewed railway crossing with and without gate control, respectively. The 'Automobiles and Motorcycles Prohibited' sign (RB-89) should be installed on the jug handle as shown.

A bike box may be placed between the vehicle stop bar and the gate to allow cyclists to advance in front of the motor vehicle queue and thereby cross the railway at close to a right angle once the gates are raised. Please refer to **Section 4.2.1.4** for further guidance regarding bike boxes.

Figure 5.31 – Bicycle Lane at Skewed Railway Crossing – Gate Controlled

(See Table 4.3 for desired and suggested minimum widths for bicycle lanes. As an option, directional arrows may be applied within the bicycle lane)

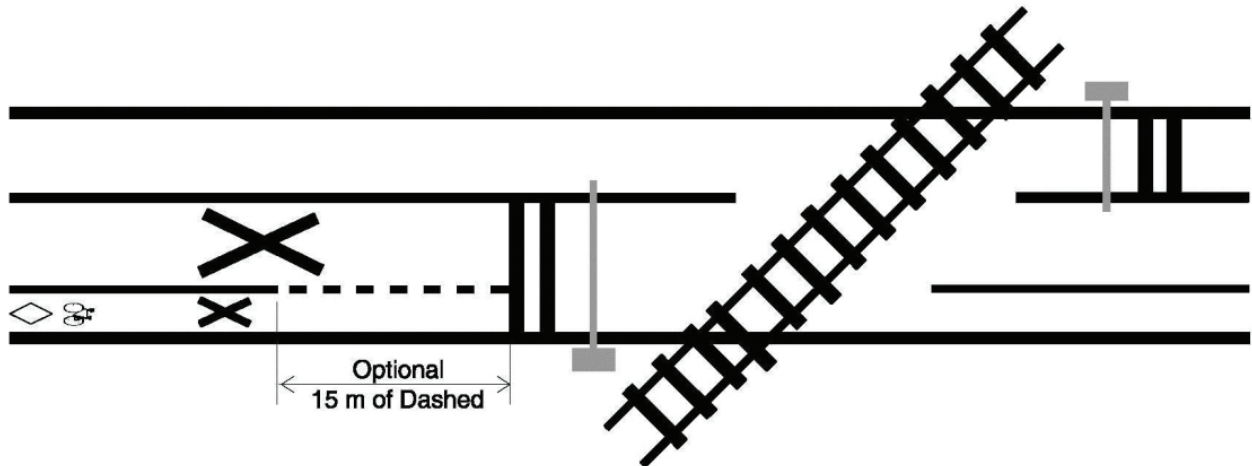

Source: Based on TAC Bikeway Traffic Control Guidelines for Canada, 2012 (Figure 42, p. 94)

Figure 5.32 – Bicycle Lane at Skewed Railway Crossing – Ungated Control

(See Table 4.3 for desired and suggested minimum widths for bicycle lanes. As an option, directional arrows may be applied within the bicycle lane)

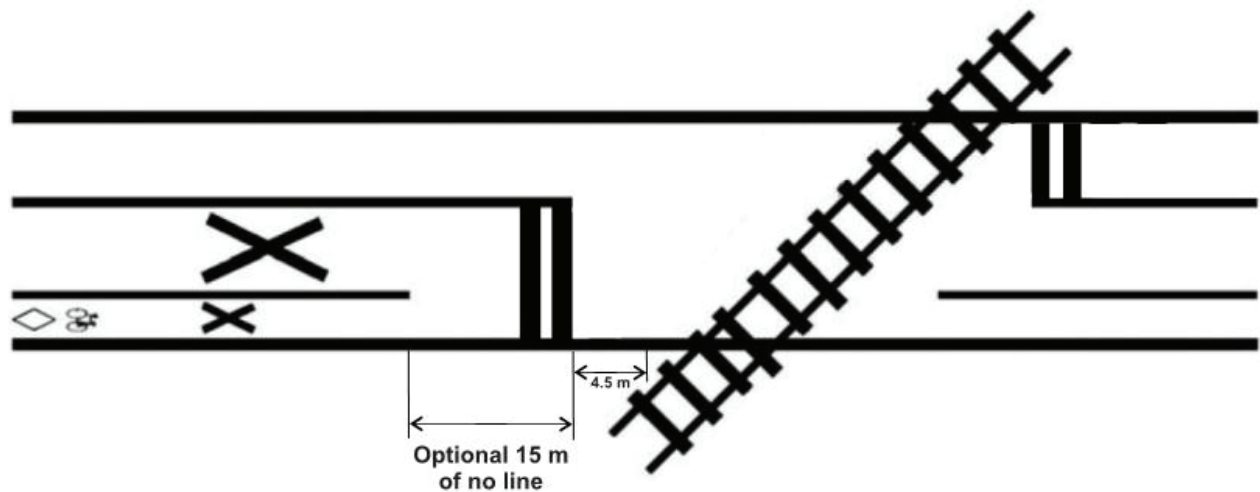

Source: Based on TAC Bikeway Traffic Control Guidelines for Canada, 2012 (Figure 44, p. 95)

Figure 5.33 – Bicycle Lane Jug Handle at Skewed Railway Crossing – Gate Controlled

(See Table 4.3 for desired and suggested minimum widths for bicycle lanes. As an option, directional arrows may be applied within the bicycle lane)

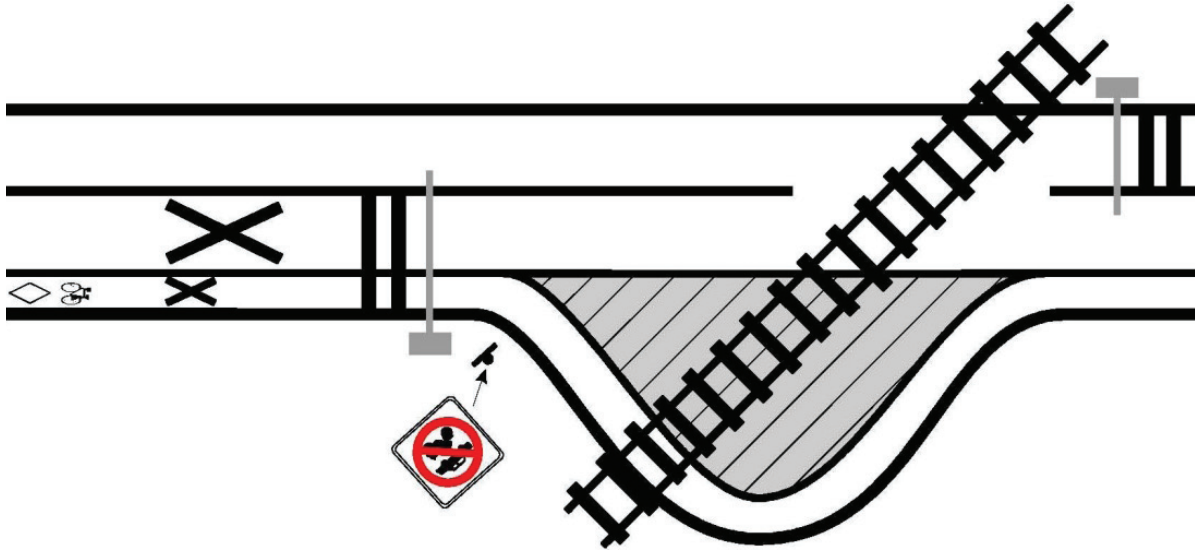

Source: Based on TAC Bikeway Traffic Control Guidelines for Canada, 2012 (Figure 45, p. 96)

Figure 5.34 – Bicycle Lane Jug Handle at Skewed Railway Crossing – Ungated Control

(See Table 4.3 for desired and suggested minimum widths for bicycle lanes. As an option, directional arrows may be applied within the bicycle lane)

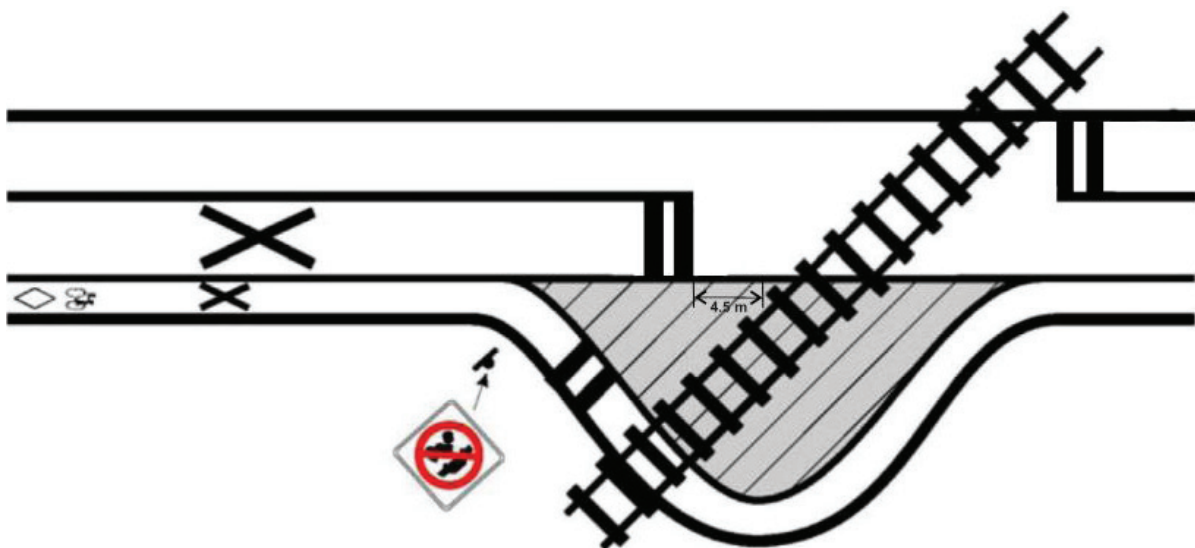

Source: Based on TAC Bikeway Traffic Control Guidelines for Canada, 2012 (Figure 43, p. 95)

5.8 Bicycle Signals

Where bicycle facilities require cyclists to pass through signalized intersections in order to continue along a designated route, a crossride should be considered in place of a crosswalk. This allows cyclists to cross the road without dismounting. See **section 5.8.1** for further details.

Practitioners should review the existing operation of that intersection and any additional conflicts that will be introduced by the proposed facilities. Where required, dedicated bicycle signal phases can be provided, as outlined in **section 5.8.2**.

5.8.1 Crossrides

At crosswalks, cyclists are required to dismount and cross as a pedestrian by walking their bicycle. Where a crossride is provided in place of a crosswalk, a cyclist may ride their bicycle within the crossing without dismounting. There are three crossride configurations for practitioners to select:

- a separate crossing, with separate space for cyclists and pedestrians, as shown in **Figure 5.35**;
- a full-sized combined crossing, with cyclist crossing areas on both sides of the pedestrian crossing, as shown in **Figure 5.36**; or
- a reduced width combined crossing, as shown in **Figure 5.37**.

Each of these crossing configurations may be used at both signalized and unsignalized intersections, although the mixed crossing is more frequently applicable in the latter case.

For all types of crossride, designers should take care to ensure that signal poles are positioned outside of the line of travel for cyclists. This will reduce the risk of collisions in poor visibility conditions. The same

applies to the pedestrian section of the crossing for visually impaired users.

See **sections 4.3.1.4 and 4.4.1.4** for applications in conjunction with raised cycle tracks and in-boulevard facilities respectively, including appropriate signage and pavement markings on the approaches.

5.8.1.1 Separate Crossride

This configuration provides separate space for cyclists and pedestrians. This is generally applied where pedestrians and cyclists are segregated into exclusive facilities on the approach to the crossing. The relative positioning of the cyclist and pedestrian crossing areas may be reversed depending on site conditions.

Figure 5.35 – Separate Crossride

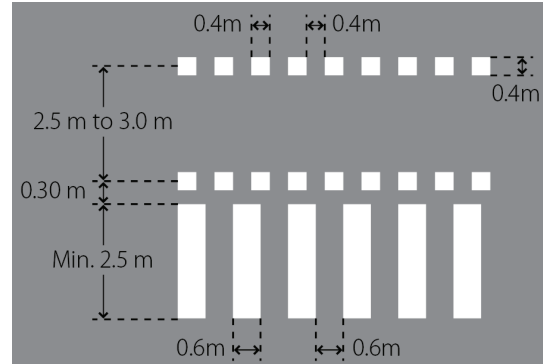

Source: Based on TAC Bikeway Traffic Control Guidelines for Canada, 2012 (Figure 39, p. 92)

5.8.1.2 Combined Crossride

Alternatively, a combined crossride may be proposed with the cyclists crossing on either side of the pedestrian area. Again, the configuration of facilities on the approach to the crossing should be considered. In particular, care must be taken to ensure that cyclists are not funnelled onto a sidewalk. This layout may, therefore, be more appropriate at midblock crossings.

Figure 5.36 – Combined Crossride

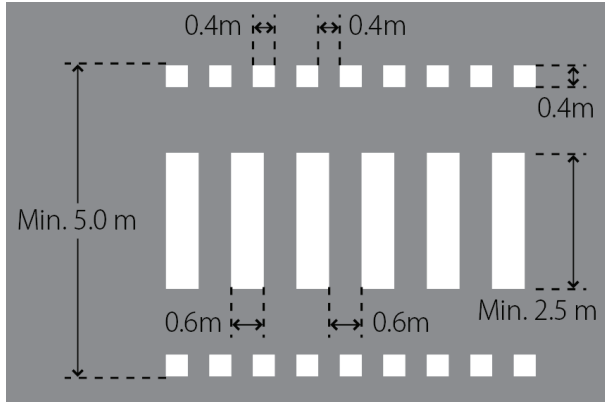

Source: TAC Bikeway Traffic Control Guidelines for Canada, 2012 (Figure 38, p. 91)

Figure 5.37 – Mixed Crossride

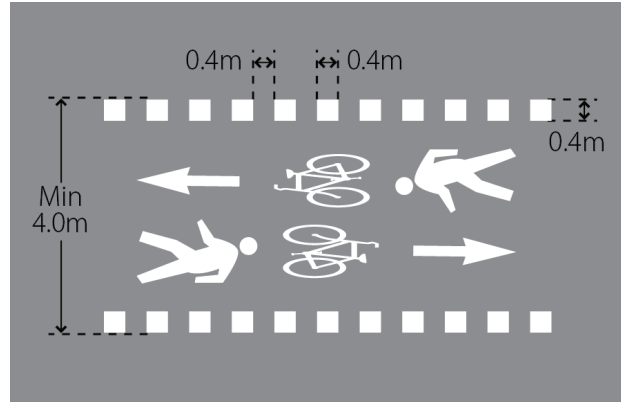

Source: MMM/ALTA, 2013

5.8.1.3 Mixed Crossride

For low volume crossings, particularly at unsignalized locations where practitioners do not anticipate queuing of pedestrians or cyclists, a mixed crossride may be implemented. This allows cyclists and pedestrians to mix and, therefore, each may use the full width of the crossing. The result is space-saving efficiencies where cyclist and pedestrian volumes are sufficiently low such that each user can safely negotiate across the roadway without impeding another user.

The operation will be similar to that of a “toucan” crossing in the United Kingdom. The standard width for a toucan is 4.0 metres. Under constrained site conditions and where cyclist and pedestrian volumes are very low, UK practitioners have reduced this to a minimum width of 3.0 metres. However, this is the exception rather than the rule. This width may be considered in Ontario, but only under constrained or retrofit conditions and following an engineering review. As always, practitioners should fully document their rationale in case they are required to justify their decisions in the future.

The fact that the mixed crossride is narrower than the combined crossride may assist practitioners in retrofitting existing crosswalks to also be used by cyclists. However, the width of any existing crossing should not be used as the sole factor in determining the width of the proposed facility. Practitioners should use their engineering judgement based on observations of pedestrians crossing and projected cyclist volumes. Following implementation, practitioners should regularly monitor sites where mixed crossrides have been implemented to ensure their safe operation. Mitigating steps, including widening or conversion to a separate or combined crossing should be taken where necessary.

5.8.1.4 MidBlock Crossride

Cyclists and pedestrians using a raised cycle track or in-boulevard facility may want to reach a destination or transit stop on the other side of the street. They may wish to continue their journey along an intersecting street or another designated facility that cannot be accessed without crossing the road.

The distances between signalized intersections may be too far to reasonably expect cyclists or pedestrians to travel there, cross over and travel back. On sections where the nearest signalized

intersection or pedestrian crossover is more than 215 metres away, practitioners should consider the provision of a midblock crossride. Particular attention should be paid where there is provision for a user group on only one side of the road, or where there are popular destinations and connections on only one side.

For unsignalized midblock crossings on multi-lane roadways, a protected space in the centre of the road, known as a 'median refuge island', may be provided. This enables cyclists, pedestrians and other trail users to cross traffic approaching from one direction at a time. The median island should be a minimum of 2.0 metres wide to accommodate regular bicycles and pedestrians with pushchairs. Where feasible, a width of 3.0 metres should be provided to accommodate bicycles with trailers.

Median refuge islands are not required for signalized midblock crossings since pedestrians and cyclists

should be able to cross on their signal indication in one attempt. However, significant portions of many major roadways have existing medians. Installation of a signalized crossing may be warranted at such a location, however it may be impractical to remove the median. In such a circumstance, the median may be retained; however, pushbuttons should be installed on the median island. This will allow any user who started to cross but was unable to reach the other side to wait on the median and register their demand for their phase.

Where a midblock pedestrian signal is not provided, the pedestrian crossing pavement markings should not be applied to avoid any confusion regarding right-of-way. **Figure 5.38** is an example of a signalized midblock pedestrian crossing with a median refuge island. While not the focus of OTM Book 18, off-road multi-use trails frequently cross roadways midblock. These crossings may also warrant the provision of formalized crossing facilities.

Figure 5.38 – MidBlock Crossride

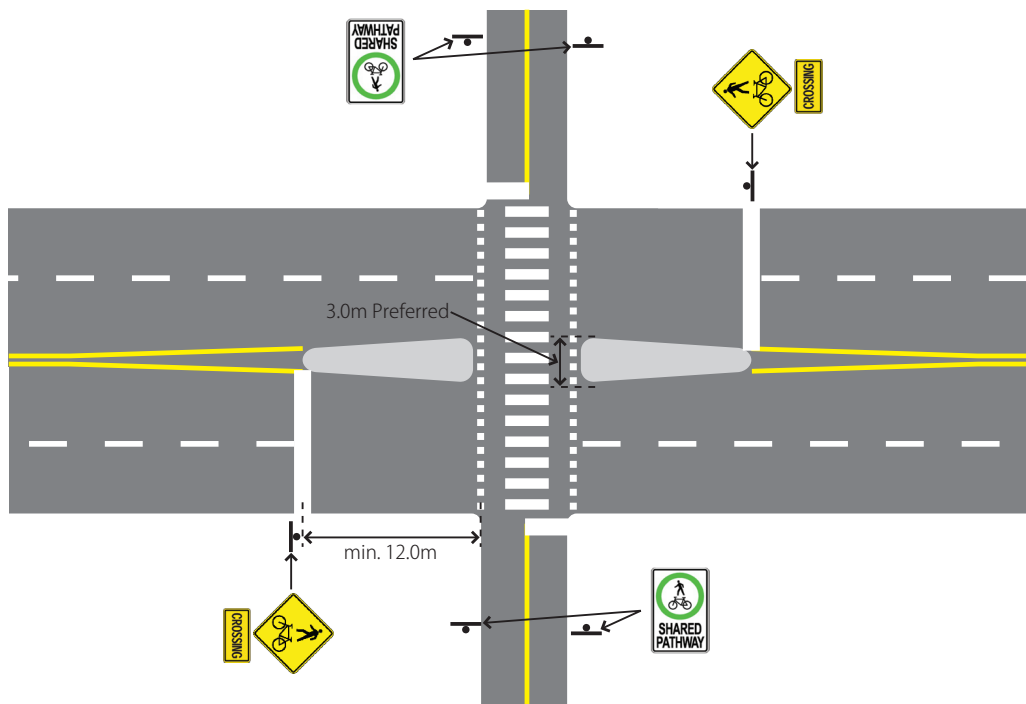

Source: MMM/ALTA, 2013

5.8.2 Intersection Signals

At intersections where bicycle facilities are provided, cyclists should be considered in the timing of the traffic signal cycle and in the selection, sensitivity and placement of traffic detection devices. Practitioners should refer to *OTM Book 12 – Traffic Signals* for design guidance on bicycle signal heads, signal timing and detector loops. **Figures 5.39 and 5.40** show examples of a bicycle signal head approved by the *Manual for Uniform Traffic Control Devices for Canada (MUTCDC)*.

Where a bicycle signal is traffic responsive, bicycle presence should be conveyed to the signal by passive bicycle detectors such as in-pavement loops, microwave or infrared detectors. Active detection, such as pushbuttons, may also be used.

A detector loop embedded within the roadway may be used to actuate the bicycle signal. Signage and

pavement markings should be applied to provide guidance to cyclists on their appropriate positioning over the detector loop. The Bicycle Stencil Sign (ID-24), shown in **Figure 5.41**, should be installed in advance of an intersection with actuated bicycle signals. This sign should be used in conjunction with the Signal Loop Detector Stencil marking, shown in **Figures 5.42 and 5.44**, which is placed over the detector loop. This is equivalent to the marking that has been implemented in some areas featuring three dots in a line. However, the stencil marking is preferred since its function is clearer to cyclists.

Where the signal actuation is through a pushbutton, a Signalized Intersection Crossing Sign Ra-14L or Ra-14R (OTM), shown in **Figure 5.43**, should be installed at the pushbutton. **Figure 5.45** provides an example of a cyclist pushbutton application.

Figure 5.39 – Example of a Bicycle Signal Head



Credit: sf.streetsblog.org

Figure 5.40 – Standard Bicycle Signal Head

(Pending HTA Approval)



Source: MUTCDC

Figure 5.41 – Bicycle Signal Loop Detector Stencil Sign



ID-24 (TAC)
(130 mm x 200 mm)

Source: TAC Bikeway Traffic Control Guidelines, 2012 (Section 5.2.4, pg. 44)

Figure 5.42 – Bicycle Signal Loop Detector Stencil Pavement Marking

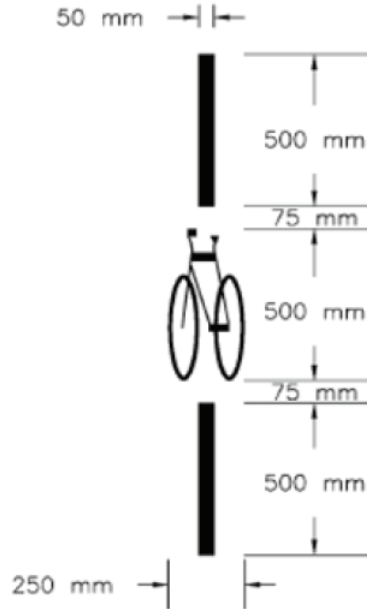

Source: TAC Bikeway Traffic Control Guidelines, 2012 (Section 7.4.6, pg. 61)

Figure 5.43 – Signalized Intersection Crossing Sign



Ra-14L(R) (OTM)
(130 mm x 200 mm)

Figure 5.44 - Example Pavement Marking for Bicycle Actuation Location



Credit: NACTO Urban Bikeway Design Guide, 2011 – Portland, OR

Figure 5.45 - Example of Cyclist Pushbutton



Credit: MMM, 2012 – Portland, OR





5.9 Other Design Considerations

5.9.1 Drainage Grates and Utility Covers

Drainage grates and utility covers within a cyclist's path may increase the risk to the cyclist.

Table 5.2 identifies some of the potential concerns that drainage grates and utility covers pose for cyclists.

Table 5.2 – Cyclist Considerations for Drainage Grates and Utility Covers

Danger		Solution
<p>Parallel bar grate inlets</p>  <p>Credit: BikePortland.org, 2008</p>	<p>Parallel bar drainage grate inlets and gaps around catch basin frames can trap bicycle tires causing loss of steering control.</p>	<p><u>Long term solution:</u> Replace old style grates with bicycle-safe and hydraulically efficient inlet grates.</p> <p><u>Short term solution:</u> Steel cross straps, or bars perpendicular to the parallel bars may be welded to the grate at 100 mm intervals.</p> <p><u>Temporary solution:</u> Place a temporary pavement marking in advance of the drainage grate hazard or utility cover.</p>
<p>Depression in roadway</p>  <p>Credit: Unknown, 2011</p>	<p>Drainage grates and utility covers are not flush with the roadway or bikeway surface.</p>	<p>Drainage grates and utility covers that are protruding above the roadway surface can be made flush by resurfacing the roadway.</p> <p>Recessed drainage grates and utility covers can be brought up to the roadway level by inserting collars.</p>
<p>Slippery when wet</p>  <p>Credit: http://donwatcher.blogspot.com, 2008</p>	<p>Drainage grates tend to be slippery when wet and can cause loss of steering control.</p>	<p>The slippery quality of the metal surfaces of drainage grates and utility covers can be reduced by texturing.</p>
<p>Potholes</p>  <p>Source: Rainer Asphalt and Concrete, 2009</p>	<p>The areas around drainage grates and utility covers are prime locations for the formation of potholes.</p>	<p>Regularly maintaining the areas around drainage grates and utility covers, plus repairing potholes and other pavement issues will reduce bicycle safety concerns.</p>

Source: Based on information from the AASHTO Guide for Planning, Design and Operation of Bicycle Facilities, 2012

When a new roadway is designed, old style grates and utility covers should not be used and, if possible, all grates and utility covers should be kept out of a cyclist's expected path. A preferable solution is the use of curb inlets to completely eliminate a cyclist's exposure to grate inlets. The installation of inlets within the curb face (designed in accordance with OPSD 400.082) may be used as a design solution as depicted in **Figure 5.46**.

However, if grates or utility covers are placed within a cyclist's path, only bicycle-safe grates with openings perpendicular or diagonal to the line of travel should be used. If grates or utility covers are placed within a cyclist's path, a grate with herring bone openings is preferred, as illustrated in **Figure 5.47**. The design of these grates should be consistent with OPSD 400.020. Alternatively, some municipalities have installed grates with square perforated openings as per OPSD 400.100.

Figure 5.46 – Catch Basin Inlet within the Curb Face



Figure 5.47 - Example of a Drainage Grate with Herring Bone Openings



5.9.2 Fences, Railings and Barriers

Fences, railings or barriers should be installed to protect cyclists from potential hazards along the bike route and contribute to a safer traffic environment. Some physical hazards that cyclist may encounter include large vertical drops, steep slopes or fixed objects that are located close proximity to the bicycle facility.

A protective fence, railing or barrier should be considered for on-road bicycle facilities adjacent to a slope of 30% or more or on a bridge or culvert. Current guidance in the *Geometric Design Standards for Ontario Highways* for guide rail implementation is sufficient to accommodate

cyclists in an adjacent paved shoulder or bike lane in most situations. Where a designated bike route is identified on a bridge or culvert, a minimum 1.37 m high barrier fence or parapet wall / railing combination should be provided, consistent with the Canadian Highway Bridge Design Code (S6-06).

Fences, railings and barriers should not be a more severe hazard than the object or condition from which the cyclist is being protected. The roadside infrastructure should have a smooth surface and a minimum 0.6 metres of lateral clearance from the bicycle facility.

5.9.3 Lighting

In most cases, roadway lighting is sufficient to light on-road bicycle facilities and provide adequate cyclist visibility at night. Lighting is especially important through underpasses or tunnels, as well as at the intersection of an in-boulevard bicycle or shared use facility and a roadway. In these cases, pedestrian scale lighting is preferred since light is distributed from the source outward in horizontal and vertical rays. Therefore, levels of horizontal and vertical illumination should be the main performance criteria in determining the choice of a light source.

Horizontal illumination is measured at pavement level and enables cyclists to see the bikeway direction, surface markings and any obstacles. Vertical illumination is measured 1.5 m above the pavement and makes vertical surfaces visible, such as road signs or approaching cyclists. Average illumination is the average lighting for all points on the roadway. Consistency in lighting, which is measured using the uniformity ratio (the relationship between the average and minimum illumination), is also an important consideration in visibility. Designers should not exceed the uniformity ratio in order to avoid sharp differences

in brightness which could interfere with a cyclist's ability to adjust to variations in illumination intensity.

At the intersection of an in-boulevard facility and an unlit street, the off-road bicycle facility must be illuminated at the prescribed level for a distance of 25 metres on either side of the intersection to ensure that cyclists are clearly visible to motorists. Transitional lighting must be provided on the street to enable motorists to adjust to the prescribed illumination level at the intersection. The length of this transition zone depends on the design speed of the street.

Where an in-boulevard facility crosses a lit street, the off-road bicycle facility must be illuminated to the same level as the street for a distance of 25 metres on either side of the intersection. The uniformity ratio for this section must be at least equal to that of the street.

Table 5.3 presents bikeway illumination levels for on-road bicycle facilities. Designers should refer to the *TAC Guide for the Design of Roadway Lighting – Chapter 9: Roadways and Interchanges* for further design guidance.

Table 5.3 – Illumination Levels for Bicycle Facilities

Level of Pedestrian or Cyclist Activity	Maintained Average Horizontal Illuminance (lux)	Maximum Horizontal Uniformity Ratio	Minimum Maintained Vertical Illuminance (lux)
High (> 50 / hour)	20.0	4.0 : 1	10.0
Medium (10 to 50 / hour)	5.0	4.0 : 1	2.0
Low (< 10 / hour)	3.0	6.0 : 1	0.8

Source: Based on the TAC Guide for the Design of Roadway Lighting, 2006

5.10 Temporary Conditions

When a roadway with a bicycle facility requires the development of a work zone for construction, maintenance or other temporary activities, every effort should be made to minimize disruption to the bicycle facility. This means that closing the bike facility and requiring cyclists to dismount should be avoided wherever possible. Cyclists should be encouraged to use general traffic lanes, and motorists should be advised to share the road if a bike facility cannot be maintained or relocated.

If a work zone in or adjacent to the cycling facility is required, temporary condition signs should be used to guide cyclists through or around the work zone. The application of these signs requires the development of a Traffic Control Plan for the work zone. Practitioners should refer to *OTM Book 7 – Temporary Conditions* for the fundamental principles of developing a temporary work zone.

All signs used for temporary conditions for bicycles should be sized appropriately for interpretation by both motorists and cyclists, and should conform to the TAC *Bikeway Traffic Control Guidelines for Canada – 2nd Edition* (January 2012). Where motorists and cyclists share the same detour route, separate detour signage for bicycles is not required. However, where a roadway with a narrow lane width is used on a bikeway detour or through a work zone, Share the Road signs Wc-19 (OTM), Shared Use Lane Single File signs WC-20 (TAC) or Motor Vehicle Passing Prohibited signs RB-33 (TAC) may be used. Refer to **Section 4.1.1.2** for the application of these signs and their supplementary tabs. Even when there is no formal cycling facility on roadways with significant cycling volumes, motorists and cyclists should be provided with positive guidance to share the road and be extra courteous.

Bicycle Lane Closed Sign

The Bicycle Lane Closed sign TC-68 (TAC) must be used to warn cyclists that the reserved bicycle lane is temporarily closed. Where a separate bicycle detour is provided, this sign should be accompanied by the appropriate Bicycle Lane Detour Markers as described below.

Figure 5.48 – Bicycle Lane Closed Sign



Tc-43 (OTM)
(450 mm x 450 mm)

Bicycle Lane Detour Markers

Bicycle Lane Detour Markers TC-70 (TAC) guide cyclists along a separate alternate route where work zone activities require the closure of a bicycle lane. These markers should be placed in advance of and at intersections to indicate to cyclists the direction of the detour route. A marker may be placed between intersections to confirm the detour route to the cyclist. A Bicycle Detour Ends Marker TC-71 (TAC) may be installed to indicate the conclusion of the detour.

Figure 5.49 – Bicycle Lane Detour Markers



Tc-41 (OTM)
(450 mm x 450 mm)



Tc-41AR (OTM)
(450 mm x 450 mm)



Tc-41R (OTM)
(450 mm x 450 mm)



Tc-42 (OTM)
(450 mm x 450 mm)

Figure 5.50 – Grooved Pavement Sign



Tc-19 (OTM)
(600 mm x 600 mm)

Figure 5.51 – Distance Advisory Tab Signs



Tc-11tA (OTM)
(300 mm x 600 mm)



TC-3tA (OTM)
(300 mm x 600 mm)

Grooved Pavement Sign

The Grooved Pavement sign Tc-19 (OTM) may be used to provide warning to road users, including motocyclists and cyclists, where the pavement has been milled or grooved. This sign may be accompanied by Distance Advisory Tab signs Tc-11tA or TC-3tA (IOTM) to indicate the distance or length of the expected condition.

6. Implementing a Bikeway Network

The fundamentals outlined in **Section 2 (Bikeway Network Planning)**, **Section 3 (Bicycle Facility Type Selection)** and **Section 4 (Bicycle Facility Design)** are brought together in this chapter. **Section 6** presents a recommended implementation process, including management structure and the necessary steps required to support the review, approval, design and implementation of bicycle facilities on roadways throughout Ontario.

6.1 Five- Stage Implementation Process

The five-stage implementation process forms the final step in the Bicycle Network Planning, Design and Implementation Process and outlines a strategy to support the successful implementation of a bicycle network. The process is a step-by-step mechanism to guide practitioners through a feasibility assessment of each bicycle route which is recommended to be undertaken at the time implementation is proposed.

A key step in this process will be the review of Municipal or Regional Master Plans and AT route priorities which will need to be considered in detail when capital infrastructure projects are identified and scheduled. This should include municipal and regional asset management programs for reconstructing or resurfacing roads, as well as any investigation of potential new road alignments. The objective is to ensure that municipal and regional assets, particularly roads designated in the Master Plan for future cycling routes, are given due regard when planning, designing and budgeting for road and infrastructure projects. This step should also apply to planning studies. Without this step, network opportunities could be lost and cost efficiencies not realized.

Building upon this primary recommendation, **Figure 6.1** illustrates the implementation process tool for guiding practitioners through the planning and design of bicycle facilities in Ontario.

The five part process is comprised of a step-by-step mechanism to confirm feasibility of each cycling route proposed. It is intended to assist practitioners from various municipal and regional departments to work together by sharing information that will facilitate the implementation of the proposed cycling route or network. Each part of the network implementation process is described in the following sections.

Figure 6.1 – Five-Stage Implementation Schedule

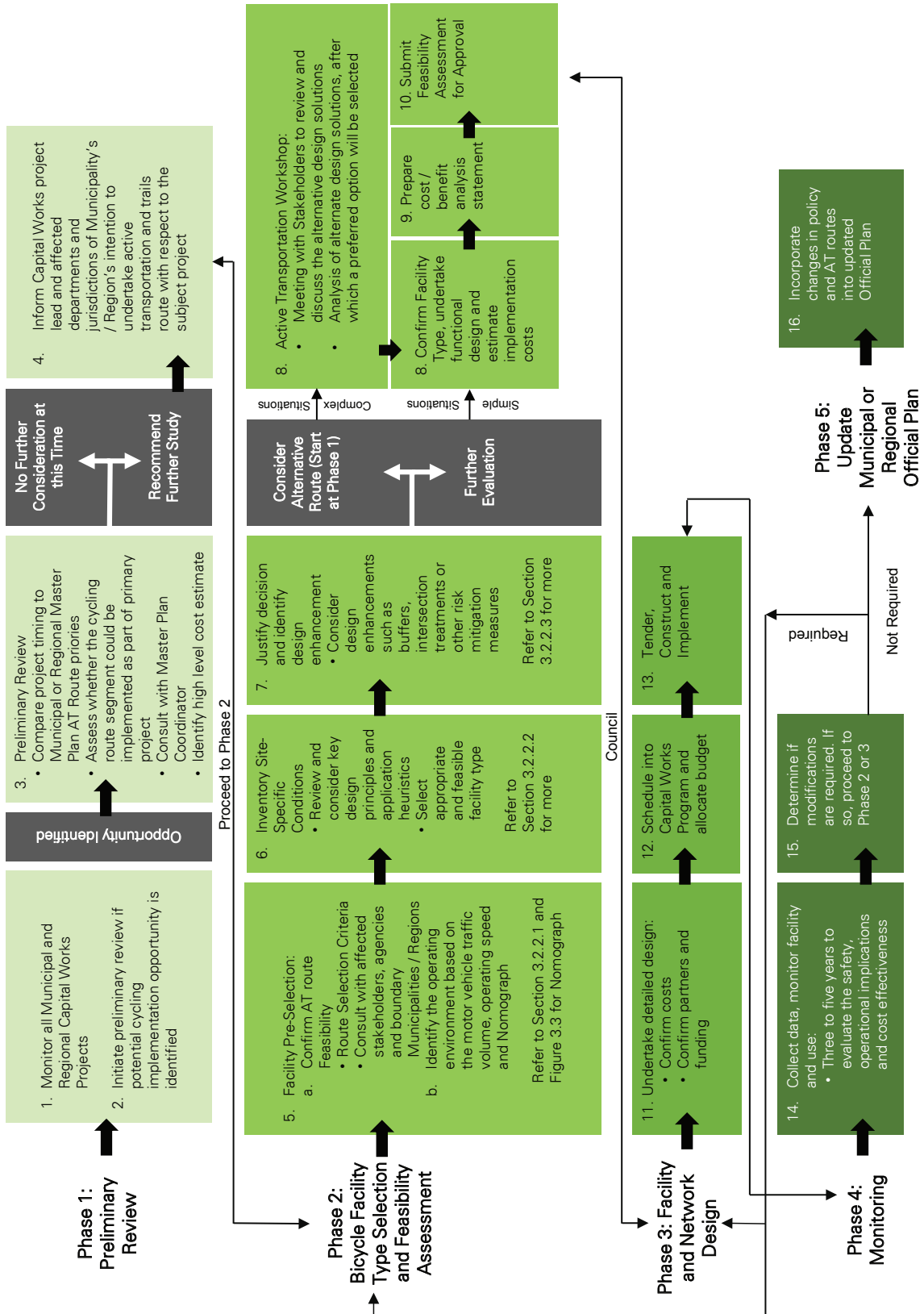

6.1.1 Phase 1: Preliminary Review

The first step in the implementation process is to identify and communicate opportunities. Practitioners should monitor all Municipal and Regional capital works programs to identify projects that link existing corridors and cycling routes identified in a Master Plan document. Through this process, road construction projects can be coordinated with the implementation of the proposed cycling facility.

If an opportunity arises to establish a new route not previously identified in the Master Plan, practitioners should undertake Phase 1: Preliminary Review.

The Preliminary Review should:

- Identify the jurisdictions involved in a project;
- Compare the timing of the project to the short and long term implementation priorities identified within the Region or Municipality;
- Assess whether the nature of the project permits the implementation of the preferred cycling facility type in a cost-effective manner; and
- Inform the project lead and affected departments whether or not a feasibility assessment should be undertaken to confirm the practicality and costs for implementing the proposed cycling route as part of the subject project.

A key aspect of this Preliminary Review is communication. Staff from various departments within the Region and Municipality should document all upcoming projects that may involve or impact a cycling facility designated in a Master Plan document. From this point forward, the

project lead, with appropriate technical support, would be expected to work through the remaining three phases of the implementation process with various departments at the Region or Municipality, as appropriate.

6.1.2 Phase 2: Bicycle Facility Type Selection

If a cycling project is confirmed through the Preliminary Review Process (Phase 1), the project lead should undertake a two-part feasibility assessment.

Part one of the assessment consists of confirming the feasibility of the route based on a review of the submitted plans, supporting route selection, planning and design criteria, as well as other relevant information. **The Bicycle Facility Type Selection Tool** presented in **Section 3** should serve as the basis for this feasibility assessment, and should include:

- A collection or confirmation of current roadway characteristics including AADT volumes, collision data and commercial vehicle percentages; and
- A field check for both on and off-road route segments to measure sight distances (if applicable), and to identify any other site characteristics that may be considered for facility type selection.

If site-specific issues, context sensitive conditions or the outcome of the feasibility assessment conclude that a facility cannot be constructed in association with a particular road improvement project, other nearby parallel routes should be closely examined at this time to determine their suitability.

If the route location is considered complex or there are significant constraints, then as part of the feasibility assessment, the practitioner should

conduct a multi-disciplinary Active Transportation Workshop. The focus of this workshop would be to review the proposed route and the design, then identify and evaluate alternative designs or enhancements. Through this rigorous technical review and assessment of the various design alternatives, the practitioner can determine whether a proposed bicycle route and associated facility type can be accommodated on the roadway, or whether an alternative route should be considered.

Once a suitable route and facility type have been selected, part two of the feasibility assessment can be undertaken. This involves production of a preliminary functional design for the preferred on or off-road cycling facility segment. It also includes an estimate of the implementation costs, including construction and signing.

6.1.3 Phase 3: Facility Design

Once approval has been obtained to implement the cycling route segment, the required detailed design should be undertaken as outlined in **Section 4 (Bicycle Facility Design)**. This step is typically completed as part of a primary capital roads project such as a road widening. The third phase of the implementation process should also include the confirmation of potential partners (if any) and cost sharing opportunities. The project should then be scheduled into the municipal capital road program, and a suitable budget should be allocated. The final step involves tendering the project, followed by construction and implementation.

It is also possible that following the detailed design stage, a decision may be made not to proceed with the preferred facility type because of costs or other constraints that may arise through the detailed design process.

6.1.4 Phase 4: Monitoring Phase

Once cycling facilities have been constructed, their design and use should be monitored to ensure that they function in the manner that was intended. When necessary, the facilities should also be upgraded and maintained to ensure continued safe use by cyclists. A monitoring team should also check that the cycling facilities comply with current design guidelines. This step will involve the collection of data to assist in the monitoring step in the process.

6.1.5 Update to the Municipality's Official Plan

The fifth phase of the implementation process includes updating the Regional or Municipal Official Plans (when the next update is scheduled) to account for changes in AT policy and network routes.

7. Support Features

This section provides information on key support features which should be considered in the planning and design of bikeway networks. Sometimes these provisions are overlooked, but often they play a key role in providing facilities that complete the bikeway system and encourage bicycle use.

Sections 7.1 and 7.2 provide information regarding bicycle parking facilities as well as shower and change rooms. These are often collectively referred to as 'end of trip facilities'. These components are important for the convenience and security of cyclists at their destinations.

Section 7.3 provides information on rest areas for recreational bicycle routes in rural areas and urban centres. Rest areas are most important in locations where users tend to stop, such as lookouts, restaurants, water fountains, access points to trails and along waterfront promenades.

Section 7.4 provides information regarding emergency and service vehicle access, which is especially important for in-boulevard facilities where access is often limited.

Also, practitioners may refer to **Section 8.7** in **Section 8** for information on the maintenance of bicycle parking facilities.

7.1 Bicycle Parking Facilities

This is an essential component of a multi-modal transportation system and necessary for encouraging more bicycle use. A lack of adequate bicycle parking supply can deter individuals from considering cycling as their primary mode of transportation.

Properly designed and strategically located bicycle parking facilities allow cyclists to securely lock their

bicycles. They can also contribute to more orderly sidewalks and parking areas in terms of appearance and flow. Factors that should be considered when planning and designing bicycle parking include:

- Type and Location of Bicycle Parking Area;
- Visibility and Security;
- Type of Bicycle Parking Facility;
- Weather Protection; and
- Clearance Considerations.

7.1.1 Type and Location of Bicycle Parking Area

There are two types of parking facilities that may be required by cyclists: short-term and long-term.

Short-term parking is required where bicycles will be left for short periods of time and, therefore, a high degree of convenience is required. It includes bicycle racks in an easily accessible location available for public use, sheltered or unsheltered with little or no surveillance. For example, **Figure 7.1** illustrates a post and ring rack located in front of a business. Alternatively, bike racks may be installed in place of on street parking as a retrofit option.

Figure 7.1 – An Example of Short-Term Parking



Credit: City of Saskatoon, 2011

Long-term parking is where bicycles will be left for long periods of time and, therefore, a high degree of security and weather protection is required. This often includes bicycle racks in an enclosed, secure area with controlled access, or bicycle lockers which are comprised of individual secure enclosures. Long-term bicycle parking facilities are often required at apartment and condominium complexes, places of employment, schools and transit hubs, such as the example shown in **Figure 7.2**.

Figure 7.2 – An Example of Long-term Parking



Credit: City of Toronto

In general, long term bicycle parking facilities should be located near washrooms and change facilities if possible. Also a portion of the bicycle parking area should be protected from the weather by means of an overhang or covered walkway, a special cover, weatherproof outdoor bicycle lockers or an indoor storage area. This is particularly important for long-term parking facilities. **Figure 7.3** illustrates a sheltered bicycle parking facility.

Figure 7.3 – Sheltered Bicycle Parking



Credit: City of Ottawa

Bicycle parking areas should be located as close as possible to the entrance of the building that the facility is intended to serve. However, the parking facility should not be located where it may inhibit pedestrian flow in and out of the building. In addition, multiple buildings in an area should not be served by one large parking facility but rather by smaller parking areas. These smaller parking areas should be placed in convenient locations at each building, but not in a manner that would obstruct utility access openings, garbage disposal bins, doorways or other building access points.

7.1.2 Visibility and Security

Fear of theft or vandalism is a common reason why individuals do not consider cycling as a mode of transportation. To encourage cycling, visible bicycle parking areas and secure bike racks or lockers are required.

Bicycle parking areas should be easy to find, clearly visible and well lit. Otherwise they will be underutilized. Theft and vandalism can be easily discouraged by placing facilities in a visible location with adequate lighting and surveillance. This is essential for the security of both bicycles and users alike.

Bicycle racks and lockers should be securely mounted to the ground so that they cannot be easily lifted or moved from their position. In addition, bicycle racks and lockers should be designed to resist being cut by common hand tools such as bolt and pipe cutters, wrenches and pry bars which can easily be concealed in backpacks.

7.1.3 Type of Bicycle Parking Facility

Bike Racks

Bike racks can vary from a simple post and ring stand for two bicycles, to more elaborate systems for multiple bicycles at destinations where use and demand are high. **Figures 7.4 to 7.6** illustrate a few good examples of bike racks. Practitioners should be aware that some designs of rack are susceptible to misuse which may decrease their capacity, such as the example shown in **Figure 7.7**.

Figure 7.4 – Post and Ring Stand



Credit: City of Ottawa

Figure 7.5 – Ring Rack



Credit: McMaster University, 2012

Figure 7.6 – Cora Bike Rack



Credit: MMM, 2013

Figure 7.7 – Improper Use of Ribbon Bike Rack



Credit: MMM, 2013

The purpose of a bike rack is to allow cyclists to securely and efficiently lock up their bicycle in a convenient location, and to provide support for the bicycle frame itself.

In general, bike racks should:

- Be installed on a hard surface and be held firmly in place;
- Support the bicycle upright by its frame in two places;
- Prevent the bicycle from tipping over;
- Be made of industrial grade materials or galvanized steel;
- Enable the bicycle frame and one or both wheels to be secured;
- Support bicycles that have a horizontal top tube instead of a diamond-shaped frame;
- Allow front-in parking so that a 'U-lock' may be used to secure the front wheel and the down tube of an upright bicycle;
- Allow back-in parking so that a 'U-lock' may be used to secure the rear wheel and seat tube of the bicycle;
- Be space efficient, allowing many bicycles to be parked in a small area; and
- They should not be placed against a wall in such a way as to restrict loading.

Figure 7.8 illustrates a poor example of bike rack design. The lack of support it offers to the frame of a parked bicycle makes the 'Bridge Rack' a 'wheel bender'. The rack is also placed against a wall in such a way that it prevents double loading. Thus, it is a poor use of space.

Figure 7.8 – The Bridge Rack is a Poor Example of a Bike Rack



Credit: Pirie Enterprises, 2007

Bike Lockers

Bike lockers differ from bike racks in that they are individual storage units most often used for long-term parking. They are enclosed and weather-protected; if the lock is spring loaded, the mechanism should be covered by a plastic flap to protect it from snow and ice. The lockers are operated by a controlled access system and may be opened using a key, swipe card or an electronic key pad located on the locker door. Systems set up for multiple users are often coin operated or secured with personal locks.

Bike lockers require more space than bike racks. On average, two standard car parking spaces can accommodate 10 individual bicycle locker spaces depending on the model size. Bike lockers should be installed on a level concrete surface 10 cm deep. They should be located close to a building entrance or on the first level of a parking garage.

In general, the bike locker design should:

- Be durable;
- Be able to withstand regular use and intense weather conditions;

- Protect users and their bicycles from theft and vandalism; and
- Hold the bicycle upright and prevent it from tipping over within the storage unit.

Figures 7.9 to 7.12 provide some examples of different bike locker designs.

Figure 7.9 – 12 Sided Polygon Bike Lockers



Credit: <http://cesavage.wordpress.com>, 2011

Figure 7.10 – Bike Locker Secured with Personal Lock



Credit: www.winnipegtransit.com, 2012

Figure 7.11 – Bike Lockers located in a Parking Garage



Credit: www.wikimedia.org, 2012

Figure 7.12 – Mesh Panels Allow for Surveillance of Locker Contents



Credit: John Luton - <http://flickrhivemind.net>, 2012

7.1.4 Clearance Considerations

Adequate clearance is required around racks and lockers to give cyclists room to manoeuvre, and to prevent conflicts with pedestrians or parked vehicles. The following factors should be considered for bike racks and lockers, respectively:

- In areas where more than one bicycle rack is installed, they should be separated by aisles, much like a typical motor vehicle parking lot. The width between aisles should be a minimum of 1.2 metres to provide enough space for one person to comfortably walk through with a bicycle.

- In high traffic areas such as transit hubs, where many users may retrieve their bicycle at the same time, aisles should be a minimum of 1.75 metres wide.
 - A 2.0-metre depth should be provided for each row since conventional bicycles are approximately 1.8 metres long.
 - Large bicycle rack areas with a high turnover of arriving and departing cyclists should have more than one entrance to help facilitate user flow.
 - If possible, the rack area should be sheltered to protect the bicycles from the elements.
 - Bicycle racks and lockers should be placed as close as possible to the entrance of the building that the facility is intended to serve without inhibiting flow in and out of the building. Where possible bicycle parking areas should be 10 to 15 metres from an entrance, and should be clearly visible along a major building approach line.
 - Bicycle racks designed for double loading should not be placed against walls or within 4.0 metres of a fire hydrant, 2.5 metres of a driveway or 10 metres of an intersection. In addition, parking areas should never obstruct emergency vehicle zones, utility access openings, bus loading areas, delivery zones, taxi zones, garbage disposal bins, doorways or other building access points.
 - Bike lockers should have adequate door clearance such that there is no conflict with other bike lockers, pedestrians or parked vehicles.
 - Where bike lockers are provided in a multi-storey parking garage, they should be located on the first level. Lockers should also be kept away from sidewalks and areas with high pedestrian traffic.
- The following images (**Figures 7.13 to 7.15**) illustrate basic parking configurations and clearances for individual 'stand' type bicycle racks as recommended by Transport Canada. Common designs include the post and ring stand, wide and narrow inverted 'U' stand, swerve stand or the lightning bolt stand.
- For more guidance, refer to bike rack and locker supplier design specifications for clearance requirements of specific facility types, or for bicycle facility parking guidelines as set out by the relevant municipality.

Figure 7.13 – Basic Dimensions for the One Bicycle per Stand Perpendicular Configuration

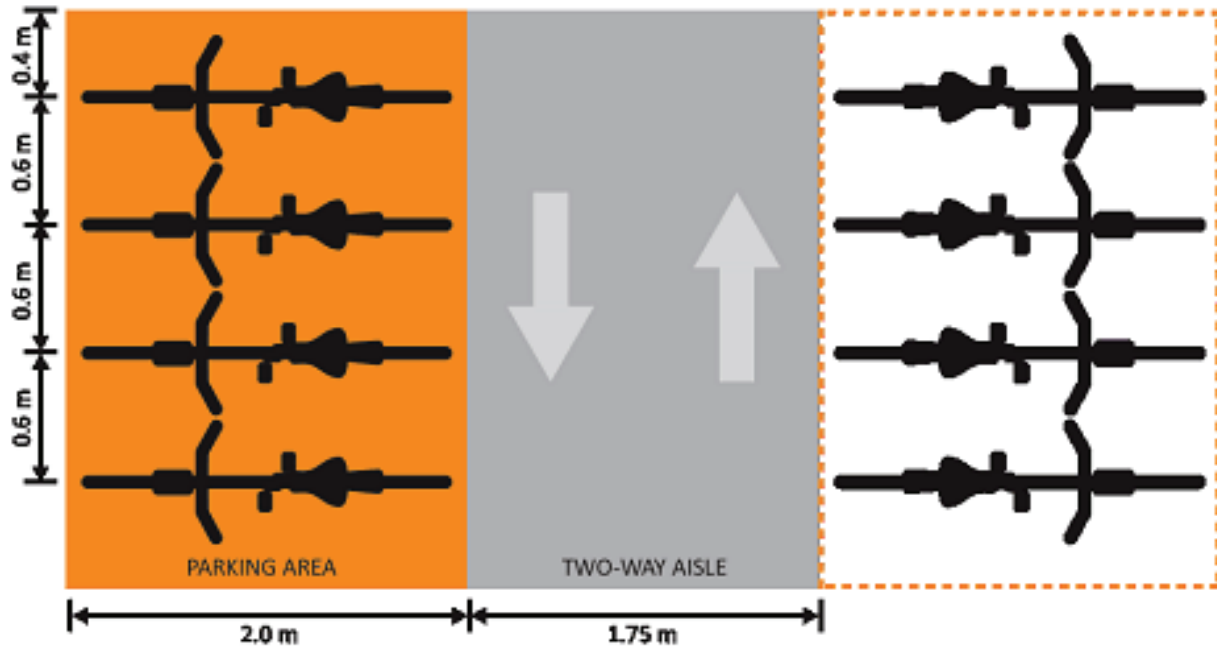

Source: Transport Canada, 2012

Figure 7.14 – Two Partially Overlapping Rows of Perpendicular Parked Bicycles

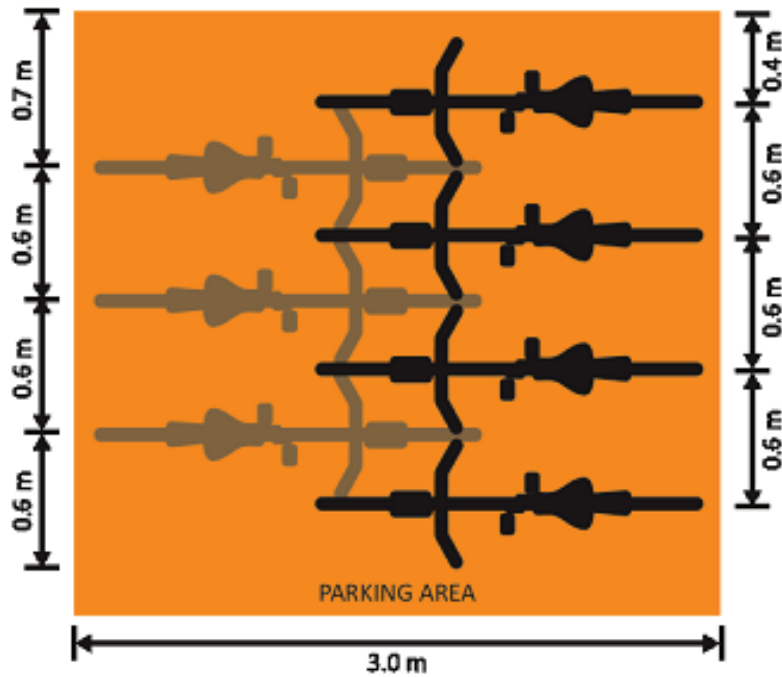

Source: Transport Canada, 2012

Figure 7.15 – Basic Dimensions for the Two Bicycles per Stand Perpendicular Configuration

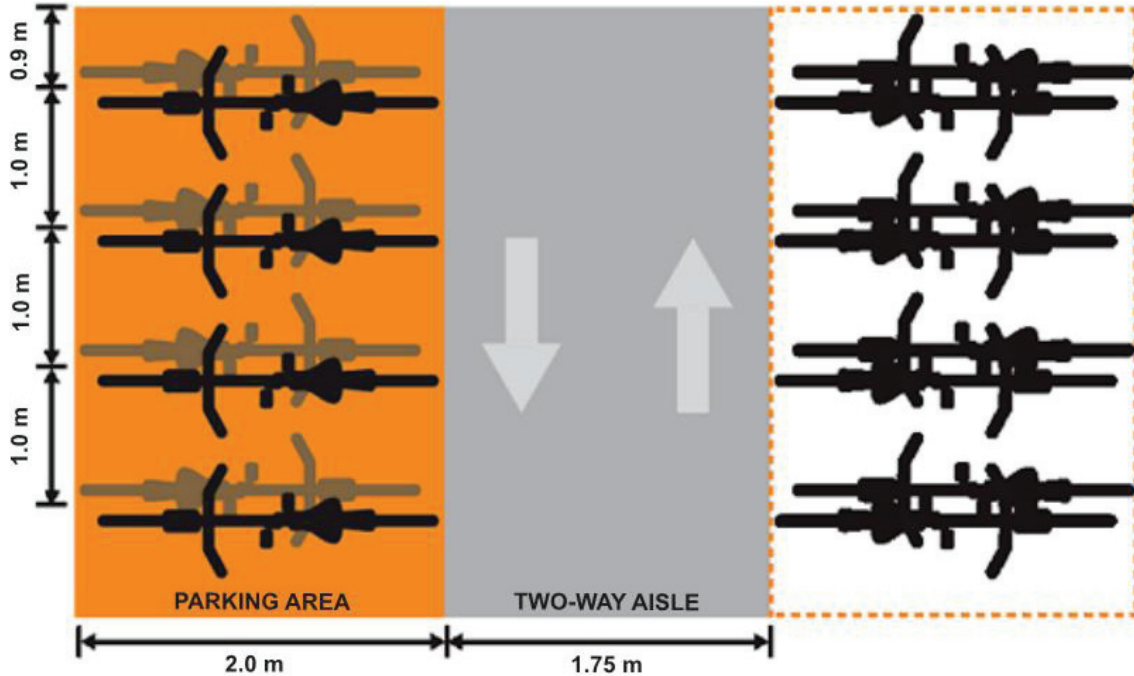

Source: Based on Transport Canada guidance, 2012

7.2 Other End-of-Trip Facilities

In addition to secure bicycle parking, non-residential developments can offer a variety of other end-of-trip facilities such as bike rooms with repair stations as well as shower and change facilities.

7.2.1 Bike Rooms

An indoor bike room is a type of long-term bicycle parking facility. Bike racks are either securely mounted to the floor or to the walls. Secure entry door systems may provide an additional level of protection. **Figure 7.16** illustrates an example of a bike room. Some bike rooms may also contain self-serve bicycle repair and maintenance stations with such items as a bike stand, air pump and basic tools. See **Figure 7.17**.

Figure 7.16 – Bike Room



Credit: <http://nycbikestorage.blogspot.ca>, 2011

Figure 7.17 – Bike Repair Station

Credit: <http://bikedenton.wordpress.com>, 2011

7.2.2 Showers and Change Rooms

These facilities can be a strong incentive to encourage bicycle use, and are particularly important for individuals who commute to work or school. The number of shower and changing stalls provided should be based on expected usage or on the amount of long-term bicycle parking being provided. Showers and change rooms should be located adjacent to bicycle parking facilities or in close proximity to the building entrance for easy access by users. Change rooms may contain day lockers for personal items and cycling equipment storage. **Figure 7.18** illustrates an example of a change room with locker facilities. In addition to lockers and benches, stalls should be provided for privacy.

Figure 7.18 – An Example of a Change Room

Credit: alibada.com, 2012

7.3 Rest Areas

Rest areas should be strategically located along routes where users are expected to stop, such as lookouts, restaurants, access points to trails and along waterfront promenades. Rest areas can be provided for both rural and urban recreational bicycle routes.

In general, rest areas should be provided at least every five kilometres on popular rural recreational routes, or at major intersections and gathering places near bicycle facilities. In urban centres, rest areas should be provided more frequently. In areas where demand is high such as along popular urban trails, waterfront promenades or trails near seniors' centres, locations for sitting and resting should be more closely spaced, typically at intervals of 100 to 250 m.

Rest areas may contain a variety of amenities such as tables, washrooms, waste receptacles and parking for automobiles and bicycles as well as bicycle route signage. The purpose, size and location of the rest area govern the amenities that are provided.

7.4 Emergency and Service Vehicle Access

Additional consideration should be given to emergency access opportunities for physically separated bicycle lanes, active transportation paths and off-road bicycle facilities. These facility types require special provisions to permit access to authorized emergency and service vehicles, while prohibiting other motorized vehicles.

The challenge lies in implementing barriers which allow the free flow of permitted path users and access for authorized emergency and service vehicles while blocking unauthorized motor vehicles. Some options that may be considered for these circumstances include:

- Removable or Retractable Bollards;
- Flex Bollards; and
- Split Path Entrances.

Removable bollards are a simple and economical option. Up to three bollards are typically placed at the access point in order to create an even number of “lanes” for users to follow as they pass through the barrier. Though the removable bollard system provides flexible access for service and emergency crews, the bollards can be difficult to maintain as the metal sleeves placed below grade can be damaged by equipment and can become jammed with gravel and debris from the path or trail. In an emergency situation this could prevent service vehicles from accessing the path.

Retractable bollards are much more expensive than removable bollards, however they are more reliable and are not as prone to damage. These benefits may be combined by using bollards that are both removable and retractable. In this situation the bollards are operated by an attendant manually; upon unlocking the bollard, the attendant can raise or lower it as required. Flex bollards are perhaps

the most economical and functional member of the bollard family since they are very inexpensive and can be quickly taken down by an emergency workers. They are also safer for trail users since their flexibility allows them to absorb energy in the event of a collision.

Another approach for keeping unauthorized motor vehicles off the bike path or trail, while still allowing emergency access, is to split the facility entrance into two narrower one-way entrance paths. A low concrete median or bushes between the paths will discourage entry by unauthorized vehicles, however emergency vehicles can drive over them in an emergency situation.

Offset gates and swing gates (also known as ‘P’ gates) are not recommended. Most cyclists have difficulty getting through offset gates without clipping their handle bars, and will often ride around the barrier to access the path. It is also more difficult to manoeuvre through these gates if a cyclist is pulling a trailer. Furthermore when trail user volumes are high, congestion can result on both sides of the offset gates as cyclists wait for the opposing direction to clear. This can lead to cyclists becoming frustrated and riding around the gates entirely.

Figure 7.19 below shows a preferred solution.

Figure 7.19 – Bollards on Finch Corridor, Toronto



Credit: MMM, 2012

8. Maintenance Strategies for Bicycle Facilities

This section outlines the key maintenance considerations for bicycle facilities. In order to support the growth in trips by bike, municipalities must be able to assure cyclists of infrastructure that is:

- Safe – without surface defects that may slow cyclists or cause them to lose control;
- Comfortable – with a smooth riding surface, preferably providing good skid resistance. The riding quality of off-road facilities should be at least as good as that of an adjacent road; and
- Aesthetically acceptable.

From the municipality's perspective, bike facilities should fulfil all legal requirements and mitigate liability risks, as well as being durable and easy to maintain.

When scheduling maintenance operations, municipalities should prioritize 'spines': long primary routes that have high connectivity with other facilities. These should benefit from year-round cleaning and snow removal, as well as surfacing works as and when required. The same should apply to Active Transportation paths that form key connections or links.

Bicycles are lighter than other vehicles and therefore cause much less wear on road surfaces; consequently the impact of those cyclists on overall maintenance costs is less than it would be if they were driving motor vehicles instead. The typical location of bike lanes also protects catch basins and the vulnerable edges of the pavement from

exposure to heavy loads, extending the life of that part of the roadway.

Monitoring is critical to effective network management. Regular inspections should be undertaken to identify defects and take remedial action within a reasonable timeframe. In many cases, monitoring of bike facilities can be incorporated into the existing roadway inspection regime.

Many maintenance issues can be mitigated at the design stage. It is recommended that a maintenance audit be undertaken prior to implementation, highlighting potential issues and making recommendations to the designer.

Through the Municipal Act and the Occupiers' Liability Act, road authorities owe a duty of care to reasonable persons using their facilities to provide for safe travel. This includes maintaining the infrastructure in a reasonably safe condition. Municipalities will ordinarily develop Quality Standards or Levels of Service for the maintenance of facilities under their control, and it is expected that this same consideration will be provided for bicycle facilities.

This section of Book 18 is not intended to be a quality standard or level of service. The material presented herein is to draw the reader's attention to the fact that the planning and design of bicycle facilities must be supported after implementation by a maintenance program that is in keeping with good practice for Ontario municipalities. A number of key maintenance issues are identified, but the list is not meant to be all inclusive.

Throughout this section, recommended maintenance tasks for practitioners are given in checklist form for ease of application.

8.1 Sweeping

A range of debris may accumulate on surfaces used by cyclists including gravel, garbage, glass, sand and wet leaves. Bicycles are more affected by surface conditions than other vehicles, and are more likely to lose control or suffer a punctured tire as a result of unexpected objects in their line of travel.

Tasks:

- Perform regular roadway cleaning with mechanical sweepers to remove debris;
- Adjust the frequency of sweeping where required by heavy wind, seasonal changes or construction activities;
- Clear sand and other debris at the beginning of the spring season;
- Pay attention to road edges and paved shoulders to avoid debris build up there;
- Provide garbage receptacles at regular intervals along in-boulevard facilities, particularly where pedestrian volumes are high;
- Incorporate visual monitoring of bike lanes and cycle tracks located within the right-of-way into existing road patrols. Clear minor debris and any small, dead animals. Where hazardous conditions exist and cannot be addressed during the patrol, erect temporary signage if required to alert cyclists.
- Avoid sweeping debris from the roadway onto Active Transportation paths and sidewalks (and vice versa).

8.2 Surface Repairs

Due to the narrow width of their wheels, cyclists are more vulnerable to pavement defects than any other type of road user. This includes pedestrians,

Figure 8.1 – An Example of Seasonal Sweeping Requirements



Credit: Ottawa Cycling Plan

who may be able to safely negotiate surface imperfections that are hazardous for cyclists.

Potential causes of defects include tree roots, freeze-thaw processes and deterioration of the surface due to age or excessive wear, as well as differential settlement of the subsoil. In all cases, the cause of the defect should be identified and addressed so that recurrence of the defect can be mitigated.

Pavement defects can include:

- Bumps or depressions;
- Cracking;
- Potholes; and
- Pavement drop-offs at shoulders.

8.2.1 Bumps and Depressions

Bumps and depressions, if significant enough to pose a hazard to cyclists, generally require the offending materials to be broken out and reset. The physical extent of such work should be carefully assessed to avoid the development of new defects at the boundary of the construction area with the existing pavement. Where possible, such measures should be coordinated with municipal resurfacing schedules. That way the entire pavement area can be refreshed either at the same time as the remedial works, or shortly after temporary works, and before new defects can form.

8.2.2 Cracking

There are three principal types of cracking: longitudinal, transverse and alligator.

On paved shoulders, cracking typically occurs perpendicular to the path of bicycle travel. Longitudinal cracking often arises along the line

Figure 8.3 – Well Maintained Bicycle Facility



Credit: MMM Group, 2011

Figure 8.2 – Poorly Maintained Bicycle Lane



Credit: The Baltimore Sun, 2010

between the outside edge of the motor vehicle travel path and the inside edge of the paved shoulder. Cracks can also form around storm sewer grates and maintenance hole covers.

Crack repair brings several benefits:

- It eliminates or minimizes the intrusion of water into the pavement structure, reducing the occurrence of freeze-thaw processes;
- It helps prevent the loss of aggregate from the edges of the cracks; and
- It reduces the rate at which the pavement deteriorates, preventing premature failure of the pavement structure.

Crack sealing should be appropriate for the type, depth and width of crack. Typical crack sealant used for motor vehicle lanes may not be appropriate for exclusive bicycle facilities. Crack sealing is the most common way to achieve this, although its effectiveness is limited:

- where crack widths are less than 3 mm;
- in cases of alligator cracking;

- for moderately to severely cupped transverse cracks;
- where there are closely spaced multiple or transverse cracks less than 10 metres apart, unless a decision has been made to rout and seal the pavement and there are only a few of these cracks; and
- for longitudinal cracks within 150 mm of the pavement edge. In this case, the cracks can be sealed without routing.
- Chip sealed surfaces are acceptable for cyclists. After some wear by motor vehicles, the surface can result in a suitable hard and relatively smooth surface for cycling. This is especially true when a finer granular material is used in the top coat application. Repair and maintenance activities should be carried out regularly in order to retain a smooth profile;
- Treatment selection decisions should factor in the type and extent of the distortion as well as any scheduled resurfacing, rehabilitation or upgrade programs;

Tasks:

- Seal cracks in accordance with the timelines outlined in the local road authority quality standard, or at the earliest opportunity, unless the aforementioned limitations apply;
- For other situations, evaluate the suitability of crack filling as an alternative;
- Where crack filling is not appropriate or the surface condition is particularly poor, resurfacing should be considered. However, it should cover a sufficiently large area to avoid negating the benefits by introducing new defects where the freshly-laid surface meets the surrounding pavement; and
- During re-surfacing projects, repave the shoulder of roadways designated as bike routes at the same time as the remainder of the travel lanes to ensure a seamless transition between the roadway and the paved shoulder.
- Winter temperatures and their impact on construction materials and processes may limit the range of treatment options available in the short term;
- Mitigating measures should be applied quickly to reduce the safety risks to cyclists due to surface distortions; and
- Where temporary measures are applied, permanent and durable solutions should be implemented as soon as is practicable.

8.2.3 Potholes

The interaction between water and traffic can lead to pothole formation. Inadequate drainage can result in standing water working its way into the road surface through tiny cracks. This seepage weakens the subsoil and leaves it susceptible to fatigue as it flexes under the weight of passing vehicles. As the surface fails, more water enters and the defect becomes progressively worse.

The following constraints should be considered for all resurfacing activities:

Bicycles are light compared to other vehicles, which reduces the likelihood of potholes forming in reserved bicycle lanes compared to general purpose lanes. However, where cyclists share the road with heavier vehicles, at intersections for example, potholes can occur within a cyclist's line of travel.

Riding over a pothole poses a significant risk to cyclists. Rims can be bent, tires can be punctured and cyclists can lose control and fall, potentially into the path of motorized traffic. If there is debris or snow on the roads, potholes may be hidden from view, increasing the risk that cyclists may ride over them.

Tasks:

- As part of general roadway inspections, special attention should be paid to potholes in bicycle facilities and on adjacent lanes;
 - Use temporary hazard markers, as shown in **Figure 8.4**, to identify potholes and warn cyclists to avoid them;
 - Patch potholes in accordance with the timelines outlined in the local road authority quality standard, or at the earliest opportunity to prevent further deterioration;
 - To patch potholes, use a mixture of dried aggregate with fluxed or cutback bitumen. A suitable bitumen emulsion may be used for the binder. Care should be taken to ensure that the patch is flush with the surrounding roadway surface, and that there are no gaps for water to seep around the edge of the patch which could cause the pothole to reform; and
- The integrity of patches should be checked as part of roadway inspections until full resurfacing can be undertaken.

8.2.4 Pavement Drop-offs At Shoulders

Edge drop-offs occur where the vertical distance between the pavement surface and the adjacent material is too great. This can result from a lack of consideration of vertical alignments at the design or construction stages, or from erosion of the surface next to the roadway. The drop can be hazardous

Figure 8.4 – Pothole Identified by Hazard Marker



Credit: Ottawa Cycling Plan, 2008

to cyclists using the shoulder since they may lose control and fall, possibly into the travelled lane, if they slip off the edge. This is particularly dangerous if the soil erosion has migrated beneath the paved shoulder causing parts of it to fail.

The edge drop will make it difficult for cyclists to re-enter the bicycle lane since the side of the tire will rub along the vertical edge of the pavement, potentially causing the cyclist to fall. The cyclist may maintain their balance by providing excessive steering input to overcome the rubbing or friction. However, when the friction diminishes, the cyclist may be propelled across the bicycle lane and into the vehicle lane, or off the other side of the trail. Please refer to **section 4.1.2** for more information on paved shoulders.

Tasks:

- Inspect all paved shoulders for edge drop-offs as part of regular roadway inspections; and
- When roads are constructed or resurfaced, ensure that the gravel adjacent to the paved shoulder is well compacted and is flush with the surface of the asphalt.

8.3 Vegetation Management

While adding aesthetic value to bicycle facilities, trees, bushes and fallen leaves also present maintenance challenges. Roots may cause surfaces to break up, leaves may block drainage grates and foliage may reduce visibility. Protruding branches, thorns or nettles can catch passing cyclists. The prevalence of vegetation along Active Transportation paths makes maintenance on those routes particularly important.

Tasks:

- Install vertical steel plates or other root barriers;
- Remove or cut back any shrubbery, long grass, brush or vegetation encroaching on the bicycle facility or blocking sight lines; and

- Undertake inspections and take preventative measures to ensure that vegetation does not obscure road signs. Any encroachment should be cleared immediately. Removal of obstructions at roadway intersections and trail crossings should be prioritized.

8.4 Maintenance of Signage and Pavement Markings

As is the case with all vehicles, cyclists rely on pavement markings and signage for guidance and direction; however, in some respects these are more critical for cyclists. Signage allows them to find their way through the bike facility network, and a missing or ineffective sign, particularly on an Active Transportation path, can cause a cyclist to lose their way. Since many bike facilities are delineated by pavement markings, keeping them visible to all road users is vital to the safety of cyclists.

Pavement markings can be obscured by snow in the winter. They can also become worn due to environmental factors, traffic and snow removal operations. Signage can become discoloured and lose reflectivity. In addition, it is sometimes subject to theft, damage and vandalism.

Tasks:

- For newly paved surfaces, apply pavement markings as soon as is practicable,
- Include pavement markings and signage in regular roadway inspections to ensure they are kept in good condition. Maintain an inventory of signs for all bicycle facilities to check that they are all in place;
- Regularly refresh pavement markings with the most durable paint available or replace them with permanent materials to ensure visibility and clarity for all road users at any time of year; and

- Replace signage that is discoloured, damaged or has lost reflectivity.

Tasks:

- Clean drainage facilities including catch basin grates and gutters; and
- Adjust the maintenance frequency based on need, the season and the amount of vegetation near the bicycle facility.

8.5 Drainage Improvements

Keeping cycling surfaces clear of water is necessary for safe riding conditions. This is particularly important in Ontario where puddle formation in winter conditions can lead to slippery surfaces, as well as accelerating the freeze-thaw processes that cause pavement to break down. Standing water can also obscure debris or surface defects that may damage bikes or cause cyclists to lose control.

Catch basin grates can become blocked due to the buildup of sediment and debris such as wet leaves. Water can also collect due to inadequate cross-slopes. The drainage of adjacent general purpose lanes should be reviewed at the same time as that for the cycling facility. Aside from being cost effective, this will also address any splashing into the bike facility that may occur due to standing water in the roadway.

8.6 Winter Maintenance

Although cycling traffic tends to decrease in the winter, there are many people who cycle year-round. In many cases, they do not own or have access to a motor vehicle, and cycling is their primary mode of travel.

Apart from being difficult to ride on, snow and ice can obscure roadway defects, pavement markings and damaging debris. For bike lanes and cycle tracks, it is not acceptable to simply install 'No Winter Maintenance' signs, so practitioners should consider liability issues. As such, snow clearing operations should include all designated bicycle facilities on or adjacent to the roadway.

Paved shoulders and Active Transportation paths, particularly those used by cyclists as network connections, should be included in snow clearing operations.

Tasks:

- Clear on-road bicycle facilities of snow at the same time as vehicle travel lanes, prioritizing long primary routes that have high connectivity with other facilities and constitute a spine of the cycling network;
- If icy conditions are found to occur, treat affected areas in accordance with the timelines outlined in the local road authority quality standard, or at the earliest opportunity;

Figure 8.5 – Poor Drainage Causes Puddling in Bike Lane



Credit: John Luton (flickr), 2006

Figure 8.6 – Bicycle Lane is Not Cleared of Snow



Credit: Hyedie, 2011 (flickr)

- Use small articulated tractors for physically separated bicycle lanes and Active Transportation paths. They are more versatile and quieter than conventional snow plows;
- Reduce or remove snow banks where they restrict travel widths or sight lines for cyclists;
- Where abrasives are used, sweep on-road bicycle facilities in accordance with the timelines outlined in the local road authority quality standard, or at the earliest opportunity, especially after major storm events;
- Clear excess snow that has accumulated adjacent to outdoor bike racks or lockers; and
- Ensure that crossrides are free from snow and are distinguishable from adjacent pedestrian-only facilities.

Practitioners should consider the following:

- Snow plowing is the preferred method of snow clearing for on-road bicycle facilities that are not physically separated;

- Plowed snow should be stored in such a way so as not to block the on-road bicycle facility or sidewalk. The boulevard between the roadway and an Active Transportation path is used for this purpose. In the case of a cycle track, snow is stored on the splash strip between the cycle facility and the roadway;
- Snow melt should drain away from bicycle and pedestrian facilities so that freeze-thaw cycles do not result in ice formation;
- Abrasives and de-icing agents should be used judiciously since they can damage bicycles, clothing and the environment;
- If a physically separated facility or Active Transportation path is too narrow for small articulated tractors, then manual snow shovelling is necessary; and
- If an Active Transportation path is planned to be open year round, the authority responsible for the path should apply reasonable maintenance guidelines.

Figure 8.7 – Bicycle Facility is Cleared of Snow



Credit: copenhagenize.com, 2010

8.7 Parking Facilities

Increasing numbers of utilitarian trips to shopping centres and other public places are being made by bike and require parking facilities. Also, as the cycling and public transit networks become more integrated, commuters will use their bikes for part of their commute, and lock them up in public bicycle parking facilities to continue their journey by bus, subway, LRT or train. Consequently, it is increasingly important to maximize the number of bicycle parking facilities available, and to keep them in good working order.

Vandalism or errant motor vehicles may cause damage to bicycle parking facilities. Environmental conditions can also affect functionality as a result of corrosion. Utilization of parking can be further reduced by the presence of abandoned bikes that effectively take the racks they occupy out of service.

Tasks:

- Inspect parking facilities and undertake on-site repairs where it is practicable and safe to do so;
- Replace facilities where repair is not feasible or cost-effective. Parking facilities should be installed such that a typical bicycle can be easily locked to each facility and that a minimum clearance of 0.6 metres is available from the end of the bicycle to the nearest curb edge; and
- Where parking is being occupied by a bicycle that is damaged or rusty, it should be tagged for removal. If the bike has not been taken away within the municipality's designated timeframe, it should be removed. Bikes which are severely damaged or stripped of parts should be removed without notice.

Refer to **Section 7.1** of **Section 7** for further information on bicycle parking facilities.

Appendix A: Glossary

Active Transportation

Active transportation is any form of transportation that is “human-powered” such as cycling, walking, running, hiking, in-line skating, skateboarding etc.

Active Transportation Path

An active transportation path, also referred to as an in-boulevard multi-use trail or path, is a cycling facility physically separated from motor vehicle traffic by a hard surfaced splash pad or by a grass strip often referred to as part of a “boulevard” or “verge” within the roadway or highway right-of-way. An active transportation path is intended for non-motorized travel modes such as walking and cycling, and is typically located in place of, or adjacent to, a sidewalk in the boulevard of a road right-of-way.

Application Heuristics

Application heuristics are knowledge based rules developed to aid practitioners. A set of 13 application heuristics have been developed to aid practitioners in Step 2 of the cycling facility type selection process outlined in Chapter 4. These heuristics link specific site conditions to appropriate facility types and supplementary design features.

Average Daily Traffic, ADT ^[3]

The total volume of traffic during a given time period, in whole days, greater than one day and less than one year, divided by the number of days in that time period.

Average Annual Daily Traffic, AADT ^[3]

The average, 24 hour, two-way traffic on a roadway for the period from January 1st to December 31st within a single calendar year.

Bicycle

A bicycle has only two tandem wheels, propelled solely by human power, upon which typically one or

two persons may travel. The *Highway Traffic Act* definition of a bicycle includes “a tricycle, a unicycle and a power-assisted bicycle, but does not include a motor-assisted bicycle.”

Bicycle Detection ^[5]

Bicycle detection at actuated traffic signals is achieved through the use of inductive in-pavement loops, or a variety of other technologies including video, infrared, microwave and ultrasonic detectors.

Bicycle Detector Loops

Bicycle detector loops are used to detect the presence of bicycles at actuated traffic signals. Bicycle detection is usually achieved through the use of in-pavement quadrupole or diagonal quadrupole inductive loops because they are bicycle-sensitive over their entire area. Pavement markings should be used to indicate to cyclists where they should position their bicycles in order to be detected.

Bicycle Facility

A bicycle facility is a general term used to denote facilities designed for use by cyclists. Some examples of cycling facilities are: signed only bike routes, signed bike routes with paved shoulders, bicycle lanes, separated bicycle lanes, cycle tracks, active transportation paths and off-road multi-use trails.

Bicycle Lane ^[1]

A bicycle lane is a portion of a roadway which has been designated by pavement markings and signage for the exclusive use of cyclists.

Bicycle Network ^[1]

A bicycle network is a system of bikeways designated through signing by the jurisdiction having authority. This system may include shared roadways, signed only bike routes, signed bike routes with paved shoulders, bicycle lanes, separated bicycle lanes, cycle tracks, active transportation paths, off-road multi-use trails, and other identifiable bicycle facilities.

Bicycle Signal Head ^[5]

A bicycle signal head is a traffic signal head specific for cyclists. The circular lenses with a red, amber and green bicycle outline on a black background differentiate the bicycle signal head from the conventional signal head used by motorized vehicles.

Bidirectional Travel

Bidirectional means moving or operating in opposite directions. Cycle tracks, active transportation paths and off-road multi-use trails may all be designed for two-way travel by cyclists if space and site conditions allow for it.

Bikeway ^{[1] & [3]}

A generic term for any road, street, path or way provided for bicycle travel, either for the exclusive use of bicycles or shared with other transportation modes. It is made up of one or more bicycle or multi-use lanes.

Bicycle Priority Street ^[7]

Bicycle priority streets are low-volume, low-speed streets that have been optimized for bicycle travel through treatments such as traffic calming and traffic reduction, signage and pavement markings, plus intersection crossing treatments. These treatments allow through movements for cyclists while discouraging similar through trips by motorized traffic.

Boulevard

A boulevard is located between the travelled portion of a highway and the edge of the right-of-way. It may include a hard surfaced splash pad or landscaped strip used to physically separate a cycling facility from the roadway in an urban context.

Buffer

A spatial or physical separation.

Clearance, Horizontal

The horizontal clearance is the width required for safe passage of a cyclist as measured in a horizontal plane. The width is measured from the edge of the essential manoeuvring space to any fixed object capable of injuring or destabilizing a cyclist using the facility.

Clearance, Vertical

The vertical clearance is the height necessary for the safe passage of a cyclist as measured in a vertical plane.

Collision

An incident resulting in property damage, personal injury or death. It involves the loss of control or the striking of one or more vehicles with another vehicle, a person, an animal or an inanimate object.

Commuter Cyclist

A commuter cyclist is an individual who repetitively cycles over the same or a similar route, and uses a bicycle primarily for travel to and from work, school or shopping.

Conflict Zone, Motorist-Cyclist

Motorist-cyclist conflict zones are areas where motorists and cyclists cross travel paths and, therefore, the risk of motorist-cyclist collisions or conflicts is higher.

Context

Context is the circumstance that forms a specific situation. See *Design Context* for more information.

Cross Section

A cross section is a diagrammatic presentation of the right-of-way profile which is at right angles to the centre line at a given location.

Crossride

A crossride is a part of the roadway intended as a crossing for pedestrians and cyclists where cyclists are permitted to ride within the crossing. This is indicated by signs, pavement markings and a traffic signal if the crossing is signalized.

Crosswalk ^[3]

A crosswalk is a part of the roadway specifically intended as a crossing for pedestrians. This is indicated by signs, pavement markings and a traffic signal if the crossing is signalized.

Curb

A vertical or sloping construction element along the edge of a pavement or shoulder forming part of a gutter. It strengthens and protects the edge of the pavement, and clearly defines the edge to vehicle operators. The surface of the curb facing the general direction of the pavement is called the “face”.

Cyclist

A cyclist is a person who operates a muscular powered or motor assisted bicycle, tricycle or unicycle.

Cyclist Operating Space

Cyclist operating space is the space needed to maintain stability when operating a bicycle. The operating space is determined by examining typical bicycle dimensions, space requirements for manoeuvring, plus horizontal and vertical clearance.

Delineation

One, or a combination of several types of devices (excluding Guide Signs) that regulate, warn or provide tracking information and guidance to motorists and cyclists.

Design Context

Site specific factors that are present create a design context that affects both design choices and key mitigation needs for a given situation. Context is very important in the design of bicycle facilities and should be considered during all planning and design phases.

Design Speed ^[3]

A speed selected for purposes of design and correlation of the geometric features of a road. It is a measure of the quality of design offered by the road.

Designated Bicycle Route ^[1]

A designated bicycle route is a segment of a bikeway network designated through signing or identification on a map by the jurisdiction having authority. Generally, designated bicycle routes are signed using the green Bike Route Marker M511 (OTM). However, it is still necessary to select the appropriate design treatment for the designated bicycle route given the route location and roadway conditions.

Designer

A person actively engaged in a discipline, or profession. For the purposes of this manual, a designer refers to a planner or engineer engaged in the planning and design of cycling facilities.

Desired Value or Dimension

The desired value or dimension is what practitioners should strive to achieve in their designs.

Driver

A driver is a person who operates a vehicle on a highway.

Experienced Cyclist

An experienced cyclist is a rider assumed to have the physical and judgmental skills needed to safely and comfortably manoeuvre a bicycle in a variety of traffic conditions.

Fitness and Sport Cyclist ^[1]

Fitness and sport cyclists ride their bicycles for exercise and skill training. Distances can be as long as 100 kilometres with cyclists often reaching speeds over 35 km/h.

Fitness and Sport Trips ^[1]

These types of recreational trips are often taken along low volume rural roadways with minimal traffic interruptions, and simulate race conditions in order to improve fitness and skill level.

Freeway ^[3]

A fully controlled access road that is limited to through traffic, with access through interchanges.

Grade Separation

Grade Separation is the vertical isolation of traveled ways through the use of a structure so that traffic crosses without interruption.

Groove

A groove is a narrow longitudinal slot in the riding surface that could restrict the steering of a bicycle wheel, such as a gap between two concrete slabs.

Guideline

A recommended (but usually not an essential) practice, method or value for a specific design feature or operating practice.

Highway

A highway is a general term denoting a public roadway for the purposes of vehicular travel, including the entire area within the right-of-way.

Highway Traffic Act (HTA)

The Ontario Highway Traffic Act.

Human Factors

The consideration of human physical, perceptual and mental limitations in engineering design, so as to optimize the relationship between people and things. The objective is to reduce error and increase user comfort.

In-Boulevard Multi-Use Path

See *Active Transportation Path*.

Inexperienced Adult Cyclist

A cyclist who may have the judgemental and physical maturity necessary to manoeuvre a bicycle in a variety of traffic conditions, but typically does not feel secure or comfortable riding in all traffic situations.

Interchange

A grade-separated intersection with one or more ramps that permit traffic to move from one roadway to another without crossing traffic streams.

Intersection ^[3] & ^[4]

The area embraced by the extension of lateral curb lines or, if none, of the rights-of-way of two or more highways that meet one another at an angle.

Intersection Approach

That part of an intersection leg used by traffic approaching the intersection.

Left-Turn Conflicts

Left-turn conflicts may occur when cyclists try to cross one or more lanes of opposing through traffic in order to turn left using the same path as motorized vehicles.

Level of Cyclist Activity

The level of cyclist activity refers to the total number of cyclists observed in a given time period (typically one hour). For the purposes of this manual, cyclist activity has been divided into three categories: 'low' (< 10 cyclists per hour), 'medium' (10 to 50 cyclists per hour) and 'high' (> 50 cyclists per hour).

Maintenance

The upkeep of highways, traffic control devices, other transportation facilities, property and equipment.

Median Island

A median island is a zone or physical island constructed in the centre of a roadway to separate opposing directions of traffic. In the context of traffic calming, it may be used to reduce the overall width of the travel lanes.

Midblock

Midblock is the segment of the roadway between two intersections.

Minimum

See *Suggested Minimum*.

Motorist

A motorist is a person who operates a motor vehicle on a highway.

Motor Vehicle

Motor vehicles include automobiles, motorcycles, motor-assisted bicycles (mopeds), and any other vehicle propelled or driven other than with muscular power. It does not include streetcars, or other vehicles designed to operate on rails, power assisted bicycles, motorized snow vehicles, traction engines, farm equipment or road-building machines.

Motor Vehicle Operating Speed (85th Percentile)

The 85th percentile motor vehicle operating speed is the speed which no more than 15% of traffic is exceeding. For the purposes of this document, 85th percentile motor vehicle operating speed has been divided into four categories: 'low' (30 to 49 km/h), 'moderate' (50 to 69 km/h), 'high' (70 to 89 km/h) and 'very high' (> 90 km/h).

MTO

MTO is synonymous with the 'Ministry of Transportation of Ontario', 'Ministry of Transportation' and 'the Ministry'.

Off-Road Cycling Facility

An off-road cycling facility for the purposes of this document includes any form of a cycling facility located outside the travelled portion of the roadway, but may or may not be within the road right-of-way. It may consist of a shared facility for use by cyclists and other non-motorized users.

Off-Road Multi-Use Trail

An off-road multi-use trail is a shared facility located outside the roadway right-of-way for use by cyclists,

pedestrians and other non-motorized users. If permitted by municipal by-law, multi-use trails may also be used by recreational motorized vehicles.

One-Way Travel

See *Unidirectional Travel*.

On-Road Cycling Facility

An on-road cycling facility for the purposes of these planning and design guidelines includes any form of a cycling facility in a road right-of-way. This includes a signed bike route or any type of designated cycling facility on the traveled portion of a roadway, as well as a shoulder bikeway or an active transportation path that is located in the boulevard of a roadway.

On-Street Parking

The use of the roadway surface or the adjacent shoulder for vehicle parking is considered 'on-street'.

Paved Path

A paved path is a path surfaced with a hard, durable material such as asphalt or concrete.

Pavement Markings

Pavement markings are painted or durable lines or symbols applied on any paved bikeway or roadway surface for guiding vehicular, cyclist and pedestrian traffic.

Pedestrian

A pedestrian is a person whose mode of transportation is by foot. It also includes a person in a non-motorized wheelchair, or person in a motorized wheelchair that cannot travel at over 10 km/h. A person pushing a bicycle or a motorized or non-motorized wheelchair is also considered a pedestrian. It does not include any person who is in or upon a vehicle, motorized or otherwise propelled.

Posted Speed ^[6]

The posted speed is the maximum vehicular speed permitted on a roadway or highway, and is displayed on a regulatory sign.

Practitioner

A practitioner is a person actively engaged in a discipline or profession. For the purposes of these guidelines, a practitioner refers to a planner, designer or engineer engaged in the planning and design of bicycle facilities.

Railroad Crossing

A location where one or more railroad tracks cross a public highway, road, street or private roadway. This includes sidewalks and pathways at or associated with the crossing.

Raised Cycle Track

A raised cycle track is a cycling facility adjacent to and often vertically separated from motor vehicle travel lanes. A raised cycle track may be designed for one-way or two-way travel, and is designated for the exclusive use by cyclists and is distinct from the sidewalk.

Ramp

A ramp is an interconnecting roadway at a traffic interchange, or any connection between highways at different levels or between parallel highways, on which the vehicles may enter or leave a designated roadway.

Recreational Cyclist

A recreational cyclist is an individual who uses a bicycle for trip enjoyment, and usually takes relatively short trips at lower speeds. The ultimate destination is of secondary importance. Fitness and sport cyclists are one type of recreational cyclist.

Recreational Trips ^[1]

Recreational trips are those where the primary objective for the cyclist is to enjoy the ride, the scenery and the company of other cyclists. These trips usually occur along off-road bicycle facilities, on quiet neighbourhood streets and rural roadways.

Refuge Island

A refuge island is provided on a street for the safety of pedestrians. It can be either a median

island on a wide street where the width may not permit pedestrians to cross the street on a single pedestrian signal indication, or as a loading island for transit such as streetcars or LRT.

Regulatory Sign

Regulatory signs advise drivers of action they should or should not take under a given set of circumstances. Disregard of a regulatory sign would usually constitute an offence.

Retrofit

A roadway may be retrofitted to improve the condition of the roadway. These projects are opportunities to redistribute space among different modes of transportation using the existing roadway platform. Retrofitting is often an appropriate and affordable solution for the implementation of bicycle facilities.

Right-of-Way ^[3]

The right-of-way is the area of land acquired for or devoted to the provision of a road.

Right-Turn Conflicts

Right-turn conflicts occur when a cyclist is proceeding straight through an intersection while a motorist is attempting to make a right turn, and to do so the motorist must cross over the on-road bicycle facility.

Risk

Risk is the probability of a situation involving exposure to danger.

Road ^[3]

A road is the entire right-of-way, comprising a public thoroughfare, including a highway, street, bridge and any other incidental structure .

Roadway ^[3]

A roadway is that part of the road that is improved, designed or ordinarily used for the passage of vehicular traffic.

Roundabout

A roundabout is a raised circular island located in the centre of an intersection, which requires vehicles to travel through the intersection in a counter-clockwise direction around the island.

Route Selection Criteria

Route selection criteria are used to aid practitioners in selecting bicycle routes that meet the needs of potential users to form a comprehensive bikeway network.

Rumble Strip ^[1]

A rumble strip is a textured or grooved pavement treatment designed to create noise and vibration to alert motorists that they have entered the shoulder of a highway.

Segregated Bicycle Lane

See *Separated Bicycle Lane*.

Separated Bicycle Lane

A separated bicycle lane is a portion of a roadway which has been designated by special pavement markings or a physical barrier and signage for the exclusive use of cyclists. This facility type provides additional spatial or physical separation between motorists and cyclists.

Shared Lane Markings ^[1]

A shared lane marking is a pavement marking symbol that indicates an appropriate position for a cyclist in a shared lane. See *Sharrows* for more information.

Shared Roadway or Signed Bike Route ^[1]

A Shared Roadway or Signed Bike Route is a road where both motorists and cyclists share the same vehicular travel lane.

Sharrows ^[4]

“Sharrows” is the term used for shared roadway lane markings or shared lane arrows. A sharrows

consists of two white chevron markings and a bicycle stencil. Sharrows are intended to guide cyclists as to where they should ride within a travel lane shared by both motorists and cyclists. They are an optional treatment and are context specific.

Shoulder ^[3]

Shoulders are areas of gravel or hard surface placed adjacent to through or auxiliary lanes. They are intended for emergency stopping and travel by emergency vehicles. They also provide structural support for the pavement.

Sidewalk ^[3]

A sidewalk is a travelled way intended exclusively for pedestrian use, following an alignment generally parallel to that of the adjacent roadway.

Sight Distance

Sight distance is measured along the normal travel path of a roadway, to the roadway surface or to a specified height above the roadway, when the view for the driver of a passenger vehicle or a bicycle is unobstructed by traffic.

Sightlines

A sightline is the ‘line of sight’ of a motorist or cyclist at any given time. Horizontal and vertical curves along the roadway as well as roadway width should be considered when providing adequate sightlines for road users. Regular maintenance of vegetation is also important in preserving sightlines.

Sign

A sign is a traffic control device mounted on a fixed or portable support which conveys a specific message by means of symbols or words, and is officially erected for the purpose of regulating, warning or guiding traffic.

Signalized Intersection

An intersection where traffic approaching from all directions is regulated by a traffic control signal.

Signed Bike Route with Paved Shoulder ^{[1] [3]}

A signed bike route with a paved shoulder is a form of bicycle facility on a road with a rural cross section. A paved shoulder is a portion of a roadway which is contiguous with the travelled way. It provides accommodation for stopped and emergency vehicles, pedestrians and cyclists as well as for lateral support of the pavement structure. A paved shoulder on a designated bike route may include a buffer zone to provide greater separation between motorists and cyclists.

Skew Angle

A skew angle is less than a right angle to a bikeway; generally an angle of 45 degrees or less.

Stopping Sight Distance

Stopping sight distance is the longitudinal space required by a motorist or cyclist, travelling at a given speed, to bring their vehicle to a stop after an object on the roadway becomes visible. It includes the distance travelled during the perception-reaction time plus the vehicle braking distance.

Suggested Minimum Value or Dimension

The suggested minimum value or dimension is the minimum that a practitioner should design to in constrained situations. Good engineering judgement should always be applied, and consideration given to the location, context and roadway characteristics. Although consistency in design and signing is an important goal, a practitioner should never assume a “one solution fits all” approach.

Tab Sign

A tab sign is smaller than the primary sign with which it is associated, and mounted below it. There are two types of tab signs:

1. Supplementary Tab Sign – contains additional, related information; and
2. Educational Tab Sign – conveys the meaning of symbols during their introductory period.

Threshold

A threshold is a limit value.

Touring Cyclist

A touring cyclist is an individual who uses a bicycle for long distance travel, usually on multi-day trips and carrying baggage.

Touring Trips ^[1]

Touring trips are often undertaken over a longer period of time than utilitarian or recreational trips. Trips are generally between urban areas and points of interest. Touring trips require more planning since the route, destinations and accommodations are important factors for the cyclist.

Traffic

Traffic includes pedestrians, ridden or herded animals, vehicles, bicycles and other conveyances, either singly or together, while using a highway for purposes of travel.

Traffic Control Devices

Traffic control devices are signs, signals or other fixtures whether permanent or temporary, placed on or adjacent to a traveled way by authority of a public body having jurisdiction to regulate, warn or guide traffic.

Traffic Control Signal

A traffic control signal is any power-operated traffic control device, whether manually, electrically or mechanically operated, by which traffic is alternately directed to stop and permitted to proceed. A traffic signal:

1. When used in general discussion, refers to a complete installation including signal heads, wiring, controller, poles and other appurtenances; or
2. When used specifically, it refers to the signal head which conveys a message to the observer. This consists of one set of no less than three coloured lenses, red, amber and green, mounted on a frame.

Traffic Volume

Traffic volume is the number of vehicles that pass a given point during a specified amount of time such as an hour, day or year.

Travelled Way ^[3]

The travelled way is that part of a roadway intended for vehicular use, excluding the shoulders. It may have a variety of surfaces, such as gravel, but is most commonly hard surfaced with asphalt or concrete.

Two-Way Travel

See *Bidirectional*.

Unidirectional Travel

Unidirectional means moving or operating in one direction. Most bicycle facilities are designed for one-way travel by cyclists.

Unsignalized Intersection

An intersection where traffic approaching from all directions is regulated by any traffic control device that is not a traffic control signal.

Utilitarian Cyclist

A utilitarian cyclist is an individual who uses a bicycle primarily for travel to and from specific destinations such as work, school, shops or recreation centres.

Utilitarian Trips ^[1]

Utilitarian trips are those for which the purpose is to reach a particular destination and are often repetitive. These include trips to places of employment, school or shopping, as well as trips that are necessary as part of an individual's daily activities.

Vehicle

For the purpose of these guidelines, a wheeled vehicle is any device which is capable of moving itself and a person, or of being moved, from place to place. This includes a bicycle.

Verge

For bicycle facility design, a verge often refers to the strip of grass used to physically separate a bicycle path from the roadway in a rural context.

Yield

To cede the right-of-way.

Youthful Cyclist

For the purpose of determining appropriate bicycle facilities, any person under 13 years of age and usually operating a bicycle with wheels of a maximum diameter of 600 mm is considered a youthful cyclist.

Sources:

^[1] Guide for the Planning, Design and Operation of Bicycle Facilities (AASHTO, 2012)

^[2] Designing Walkable Urban Thoroughfares: A Context Sensitive Approach (ITE)

^[3] Geometric Design Standards for Ontario Highways (MTO, 1985)

^[4] Guidelines for the Design and Application of Bikeway Pavement Markings (TAC, August 2007)

^[5] Traffic Signal Guidelines for Bicycles (TAC, 2012)

^[6] TAC Geometric Design Guide for Canadian Roads (TAC, 1999)

^[7] IBPI Fundamentals of Bicycle Boulevard Planning & Design (IBPI, 2009)





**Book
18**

**Ontario
Traffic
Manual**

December 2013

